

Datasheet

Part no. and prices: See pricelist



VITOPLEX 200 Type SX2A

Low temperature oil/gas boilers

- Three-pass boiler
- For operation with modulating boiler water temperature
- With Vitotrans 300 as condensing unit

Benefits at a glance

- Economical and environmentally responsible due to modulating boiler water temperature.
- Standard seasonal efficiency [to DIN] for operation with fuel oil: 89 % (H_s) [gross cv].
- Optional stainless steel flue gas/water heat exchanger enables the utilisation of condensing technology for higher standard seasonal efficiency [to DIN].
- Three-pass boiler with low combustion chamber loading, resulting in clean combustion with low emissions.
- Wide water galleries and large water capacity provide excellent natural circulation and reliable heat transfer.
- Large water content results in long burner runtimes and fewer switching intervals, thereby protecting the environment.

- Compact design for easy transportation into boiler rooms – important for modernisation projects.
- Easy to use Vitotronic control unit with colour touchscreen.
- Integral LAN interface for internet communication and integral WLAN for service interface.
- Economical and safe operation of the heating system through the Vitotronic control system with communication capability which, in conjunction with Vitogate 300 (accessories), enables integration into building management systems.
- Vitocontrol control panel can be supplied on request.

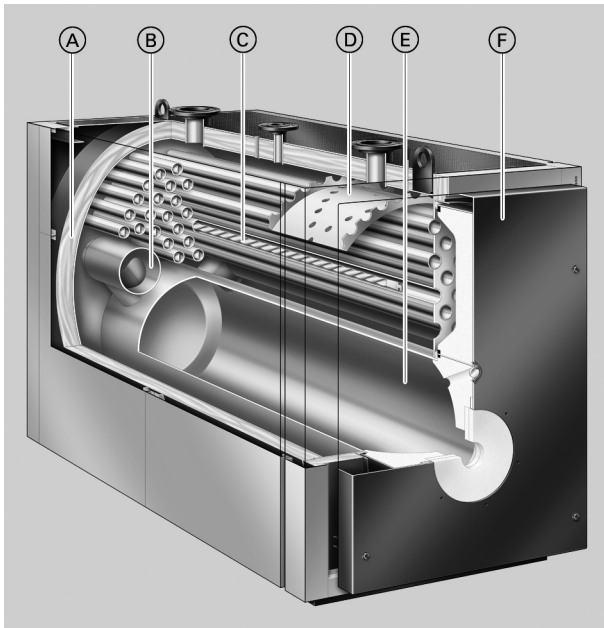

- Ⓐ Highly effective thermal insulation
- Ⓑ Second hot gas flue
- Ⓒ Third hot gas flue
- Ⓓ Water deflector with return injectors
- Ⓔ Combustion chamber (first pass)
- Ⓕ Boiler door

Boiler specification

Specification

Rated heating output	kW	700	900	1100	1300	1600	1950
Rated heat input	kW	761	978	1196	1413	1739	2120
CE designation		CE-0085BQ0020					
According to Gas Appliances Directive							
Permiss. flow temperature (= safety temperature)	°C	110 (up to 120 °C on request)					
Permiss. operating temperature	°C	95					
Permiss. operating pressure	bar	6					
	kPa	600					
Pressure drop on the hot gas side	mbar	2.7	4.6	4.0	5.7	8.2	8.5
	Pa	270	460	400	570	820	850
Boiler body dimensions							
Length (dim. k) ^{*1}	mm	2200	2500	2450	2670	3075	3075
Width (dim. c)	mm	1085	1085	1180	1180	1280	1280
Height (incl. connectors) (dim. e)	mm	1670	1670	1900	1900	2120	2120
Total dimensions							
Total length (dim. f)	mm	2280	2580	2530	2750	3175	3175
Total width							
– Incl. control unit (dim. a)	mm	1460	1460	1555	1555	1660	1660
– Excl. control unit (dim. b)	mm	1285	1285	1380	1380	1485	1485
Total height (incl. lifting eyes) (dim. h)	mm	1690	1690	1920	1920	2140	2140
Height of anti-vibration boiler supports (under load)	mm	37	37	37	37	37	37
Foundation							
Length	mm	1900	2200	2150	2300	2700	2700
Width	mm	1200	1200	1300	1300	1400	1400
Combustion chamber diameter	mm	620	620	720	720	720 ^{*2}	720 ^{*2}
Combustion chamber length	mm	1700	2000	1930	2150	2530	2530
Weight boiler body	kg	1620	1870	2120	2340	3000	3580
Total weight	kg	1725	1985	2255	2485	3180	3760
Boiler incl. thermal insulation and boiler control unit							
Capacity boiler water	litres	935	1325	1525	1690	2510	2420
Boiler connections							
Boiler flow and return	PN 6 DN	100	100	125	125	150	150
Safety connection (safety valve)	PN 16 DN	50	50	65	65	65	65
Drain (male thread)	R	1¼	1¼	1¼	1¼	1¼	1¼
Flue gas parameters^{*3}							
Temperature (at 60 °C boiler water temperature)							
– At rated heating output	°C			180			
– At partial load	°C			125			
Temperature (at 80 °C boiler water temperature)	°C			195			
Flue gas mass flow rate							
– For natural gas	kg/h	1.5225 x combustion output in kW					
– For fuel oil EL	kg/h	1.5 x combustion output in kW					
Flue gas connection	Ø mm	300	300	350	350	400	400
Total gas capacity	m ³	0.90	1.00	1.35	1.45	2.50	2.50
Combustion chamber, hot gas flues, return pipes, bend and flue gas collector							
Standard seasonal efficiency [to DIN] (for operation with fuel oil) At heating system temperature 75/60 °C	%	89 (H _s) [gross cv]					
Standby loss q _{B,70}	%	0.15	0.13	0.13	0.12	0.13	0.11

*1 Boiler door removed.

*2 Conical combustion chamber 720/840 mm (combustion chamber diameter front/rear)

*3 Calculation values for sizing the flue system to EN 13384, relative to 13.2 % CO₂ for fuel oil EL and 10 % CO₂ for natural gas.

Flue gas temperatures captured as gross values at 20 °C combustion air temperature.

The details for partial load refer to an output of 60 % of rated heating output. If the partial load differs (depending on operating mode), calculate the flue gas mass flow rate accordingly.

Boiler specification (cont.)

Rated heating output	kW	700	900	1100	1300	1600	1950
Matching Vitotrans 300							
– Gas operation	Part no.	Z007212		Z007213		Z007214	
– Oil operation	Part no.	Z007215		Z007216		Z007217	
Rated heating output							
Boiler with Vitotrans 300							
– Gas operation	kW	773.5	994.5	1215.0	1436.0	1768.0	2154.0
– Oil operation	kW	750.0	964.0	1179.0	1393.0	1715.0	2090.0
CE designation		CE-0085BS0287					
Vitotrans 300 in conjunction with boiler as a condensing unit							
Pressure drop on the hot gas side		3.2		5.2		10.0	
		320		520		1000	
Boiler with Vitotrans 300							
Total length		3820		4120		4470	
Boiler with Vitotrans 300 excl. burner							

Dimensions

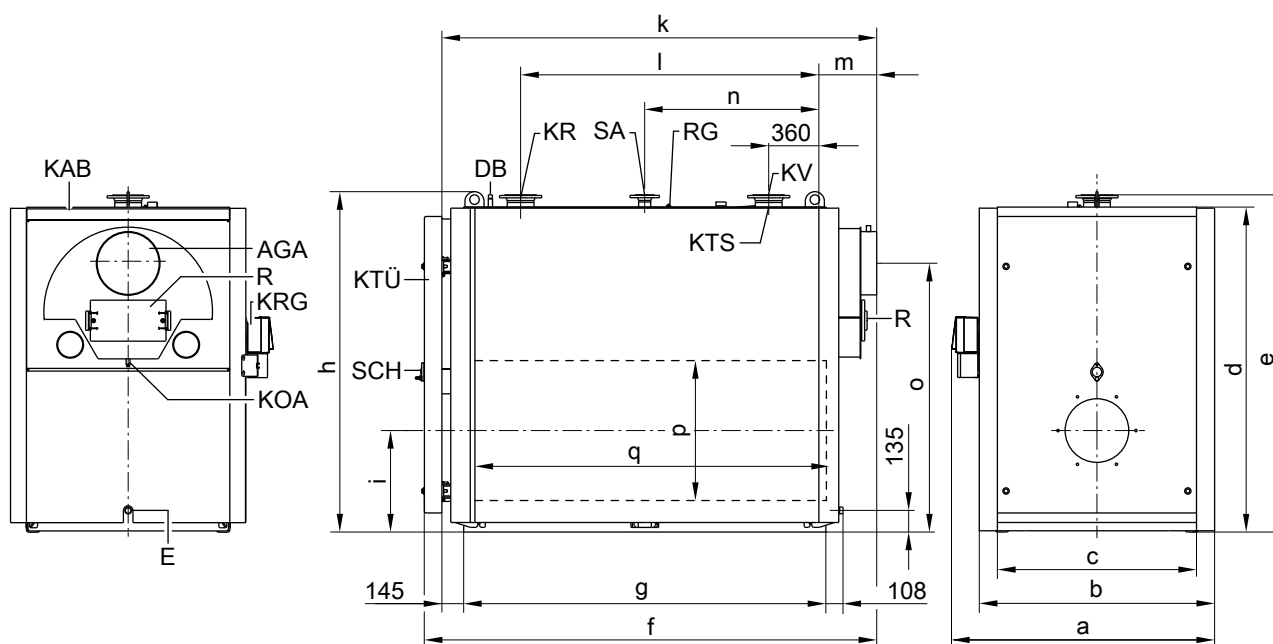

AGA	Flue outlet	KTS	Boiler water temperature sensor (shown offset)
DB	Female connection for maximum pressure limiter (R ½, male thread)	KTÜ	Boiler door
E	Drain	KV	Boiler flow
KAB	Boiler cover (walk-on)	R	Cleaning aperture
KOA	Condensate drain	RG	Female connection for additional control equipment (R ½, male thread)
KR	Boiler return	SA	Safety connection (safety valve)
KRG	Boiler control unit	SCH	Inspection port

Dimensions

Rated heating output	kW	700	900	1100	1300	1600	1950
a	mm	1460	1460	1555	1555	1660	1660
b	mm	1285	1285	1380	1380	1485	1485
c	mm	1085	1085	1180	1180	1280	1280
d	mm	1590	1590	1815	1815	2035	2035
e	mm	1670	1670	1900	1900	2120	2120
f	mm	2280	2580	2530	2750	3175	3175
g (length of base rails)	mm	1775	2075	2005	2225	2610	2610
h	mm	1690	1690	1920	1920	2140	2140
i	mm	525	525	580	580	640	640
k (transport dimension)	mm	2200	2500	2450	2670	3075	3075
l	mm	1420	1720	1650	1870	2250	2250

Boiler specification (cont.)

Rated heating output	kW	700	900	1100	1300	1600	1950
m	mm	280	280	300	300	320	320
n	mm	890	1040	1005	1115	1305	1305
o	mm	1270	1270	1480	1480	1690	1690
p	∅ mm	620	620	720	720	720 ^{*4}	720 ^{*4}
q	mm	1700	2000	1930	2150	2530	2530

Dim. k: With boiler door removed

Siting

Minimum clearances

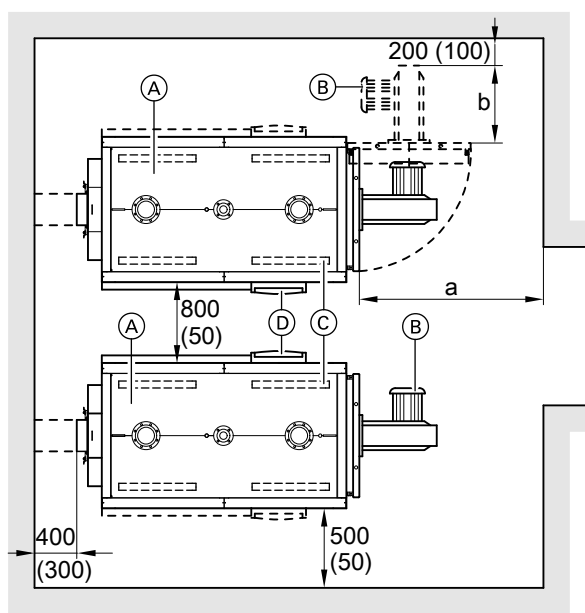

- (A) Boiler
- (B) Burner
- (C) Anti-vibration boiler supports
- (D) Boiler control unit

Dimensions

Rated heating output	kW	700	900	1100	1300	1600	1950
a	mm	2000	2000	2200	2400	2900	2900
b	mm	Installed burner length					

Siting conditions

- Prevent air contamination by halogenated hydrocarbons (e.g. as contained in sprays, paints, solvents and cleaning agents)
- Prevent very dusty conditions
- Prevent high levels of humidity
- Prevent frost and ensure good ventilation

The stated dimensions should be observed to ensure straightforward installation and maintenance. Where space is tight, only the minimum clearances (dimensions in brackets) need to be maintained. In the delivered condition, the boiler door is fitted so it opens to the right. The hinge pins can be repositioned so the door opens to the left.

Dim. a: Maintain this space in front of the boiler to enable the hot gas flues to be cleaned.

If the control units are fitted on opposite sides of the boilers, the 800 mm clearance between the individual boilers can be reduced to 50 mm.

Otherwise the system may suffer faults and damage.

In rooms where air contamination through **halogenated hydrocarbons** may occur, install the boiler only if adequate measures can be taken to provide a supply of uncontaminated combustion air.

Burner installation

Fit the burner plate included in the standard delivery on the hinged boiler door.

The burner must be fitted to the burner plate; mounting it directly onto the boiler door without a burner plate is not possible.

Drill the supplied burner plate on site, in accordance with the burner dimensions.

Burner plates can be prepared at the factory on request (chargeable option). If this is required, state the burner make and type when ordering.

The flame tube must protrude from the thermal insulation of the boiler door.

The burner must not exceed a total weight of 180 kg, otherwise supports will need to be provided on site.

^{*4} Conical combustion chamber 720/840 mm (combustion chamber diameter front/rear)

Boiler specification (cont.)

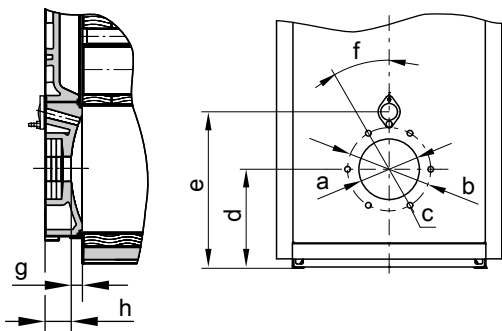

Dimensions

Rated heating output	kW	700	900	1100	1300	1600	1950
a	∅mm	350	350	400	400	400	400
b	∅mm	400	400	490	490	490	490
c	Quantity/ thread	6/M12					
d	mm	525	525	580	580	640	640
e	mm	785	785	885	885	970	970
f	°	15	15	30	30	30	30
g	mm	75	75	75	75	75	75
h	mm	150	150	150	150	170	170

Pressure drop on the heating water side

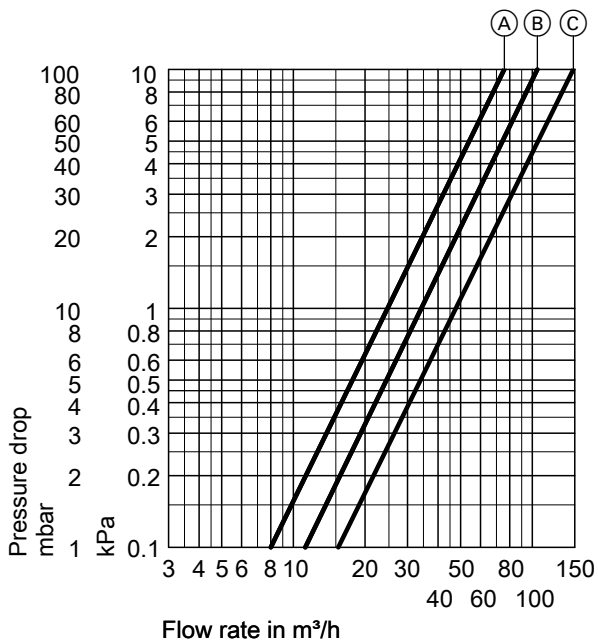

The Vitoplex 200 is only suitable for fully pumped hot water heating systems.

- (A) Rated heating output 700 and 900 kW
- (B) Rated heating output 1100 and 1300 kW
- (C) Rated heating output 1600 and 1950 kW

Vitotrans 300 specification

Specification

Vitotrans 300 – gas operation	Part no.	Z007212	Z007213	Z007214
– oil operation	Part no.	Z007215	Z007216	Z007217
Rated boiler heating output	kW	620-900	630-1300	1600-2000
Rated heating output of the Vitotrans 300 for				
– gas operation	from kW	62.0	63.0	160.0
	to kW	94.5	136.0	204.0
– oil operation	from kW	43.0	44.0	115.0
	to kW	64.0	93.0	140.0
Permiss. operating pressure	bar	6	6	6
	kPa	600	600	600
Permiss. flow temperature (= safety temperature)	°C	110 (120)	110 (120)	110 (120)
Pressure drop on the hot gas side	mbar	0.4-0.8	0.4-1.6	1.0-1.75
	Pa	40-80	40-160	100-175
Flue gas mass flow rate	from kg/h	1010	1057	2670
	to kg/h	1500	2160	3300
Overall dimensions				
Total length (dim. f)	mm	1046	1046	1200
Total width (dim. m), incl. mating flanges	mm	1097	1097	1226
Total height (dim. i)	mm	1783	1783	2024
Transport dimensions				
Length (dim. f)	mm	1046	1046	1200
Width (dim. m), excl. mating flanges	mm	989	989	1112
Height (dim. a)	mm	1674	1674	1915
Total weight heat exchanger incl. thermal insulation	kg	355	355	470
Content				
Heating water	litres	215	215	295
Flue gas	m ³	0.336	0.336	0.544
Connections				
Heating water flow and return	PN 16 DN	100	100	125
Condensate drain	∅ mm	32	32	32
Flue gas connection ^{*5}	DN	300	300	350

Rated heating output range of the Vitotrans 300 and flue gas temperature

Heating output of the Vitotrans 300 with flue gas cooling of 200/65 °C during gas operation and 200/70 °C during oil operation, with a heating water temperature rise in the Vitotrans 300 from 40 °C to 42.5 °C.

For conversion to other temperatures, see chapter "Output data".

Pressure drop on the hot gas side

Pressure drop on the hot gas side at rated heating output. The burner must overcome the hot gas pressure drop of the boiler, the Vitotrans 300 and the flue pipe.

Tested quality

CE CE designation according to current EC Directives at a permissible flow temperature (safety temperature) of up to 110 °C to EN 12828.

Vitotrans 300 specification (cont.)

Dimensions

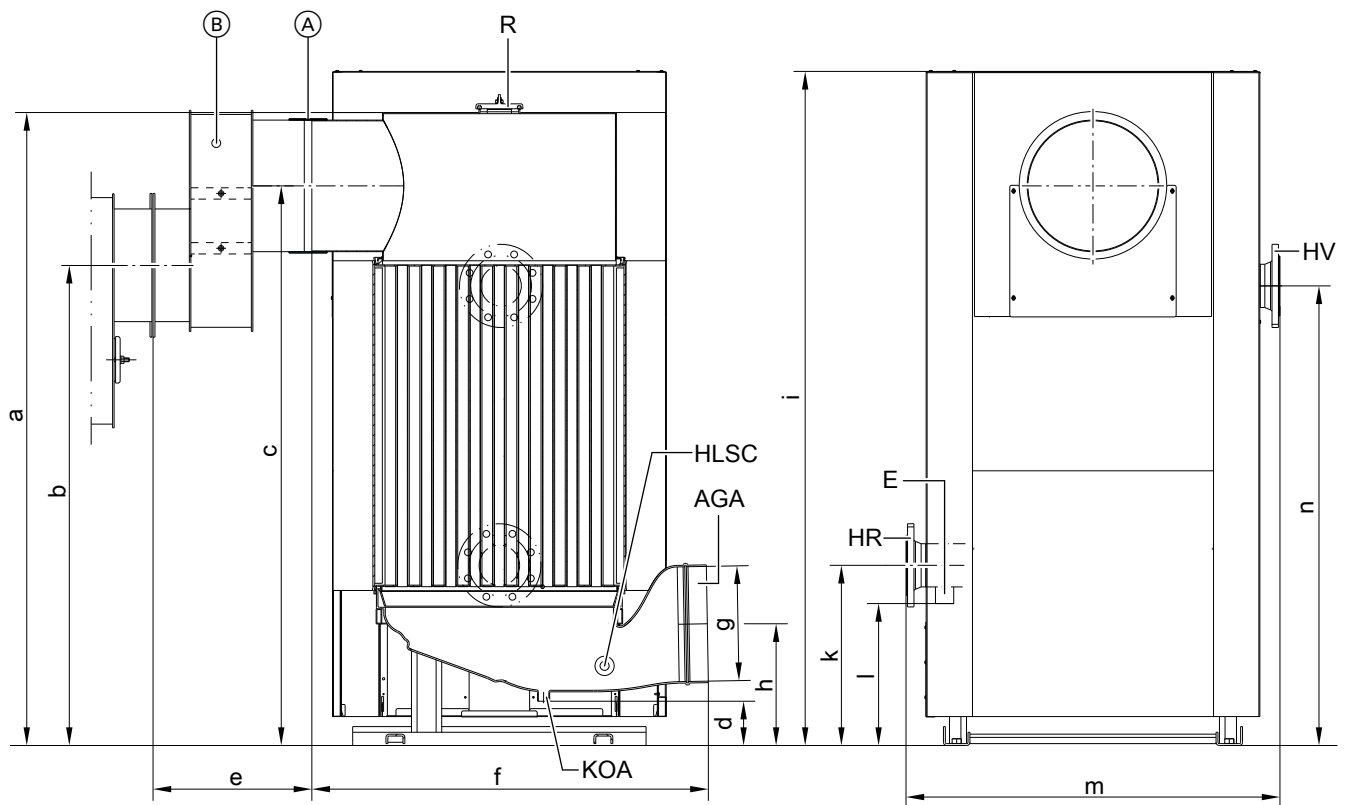

Ⓐ	Connection collar	HR	Heating water return (inlet)
Ⓑ	Offset flue adaptor, only with Z007 212 and Z007 215 for Vitoplex boilers	HV	Heating water flow (outlet)
AGA	Flue outlet	KOA	Condensate drain
E	Drain connector	R	Cleaning aperture
		HLSC	Fem. connection for flue gas high limit safety cut-out

Dimensions

Part no.		Z007212		Z007213		Z007214	
		Z007215		Z007216		Z007217	
a	mm	1674		1674		1825	
b	mm	1270		1480		1690	
c	mm	1480		1480		1690	
d	mm	116		116		116	
e	mm	420		15		15	
f	mm	1046		1046		1200	
g (internal)	∅ mm	301		301		352	
h	mm	321		321		356	
i	mm	1783		1783		1934	
k	mm	476		476		580	
l	mm	375		375		469	
m	mm	989		989		1112	
n	mm	1215		1215		1297	

Note

Height is adjustable for Vitotrans 300.

Delivered condition

Heat exchanger body with fitted flue gas header and integral feet.
Mating flanges and screws are fitted to the connector.

- 1 Crate with offset flue adaptor
- 1 Box with thermal insulation for offset flue adaptor

- 1 Box with thermal insulation for flue gas/water heat exchanger
- 1 Box with collar

Vitotrans 300 specification (cont.)

Pressure drop on the heating water side

Part no. Z007212 to Z007217

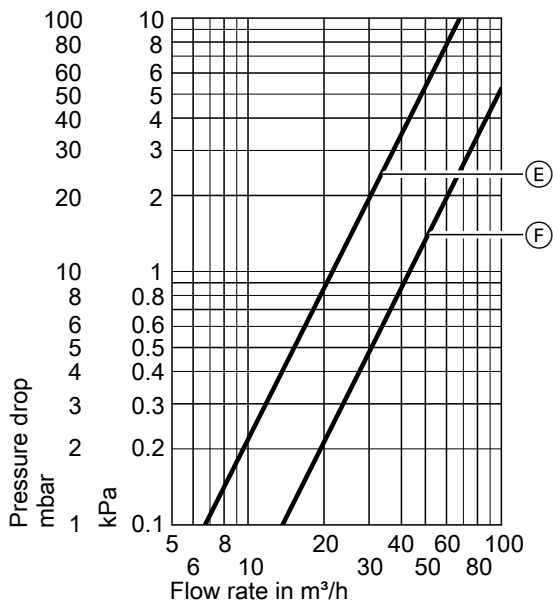

Part no.	Curve
Z007212	Ⓔ
Z007213	
Z007215	
Z007216	
Z007214	Ⓕ
Z007217	

Output data

Vitotrans 300 for gas operation

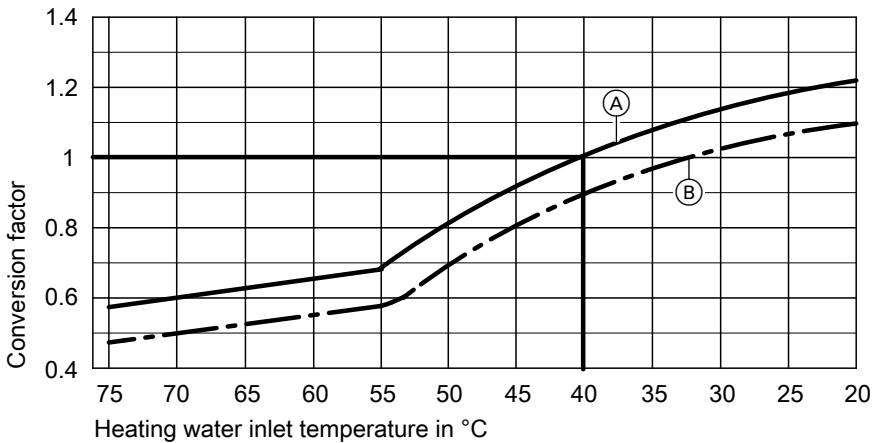

- Ⓐ Flue gas inlet temperature 200 °C
- Ⓑ Flue gas inlet temperature 180 °C

Conversion of the output data

The heating output data of the Vitotrans 300 flue gas/water heat exchanger refers to a flue gas inlet temperature of 200 °C and a heating water inlet temperature into the heat exchanger of 40 °C.

For different conditions the heating output can be calculated by multiplying the specified rated heating output by the conversion factor established from the diagram.

Delivered condition of the boiler

Boiler shell with fitted boiler door, fitted cleaning cover and permanently fitted boiler cover.

Mating flanges are fitted to all connectors.

The adjusting screws and burner plate can be found inside the combustion chamber.

- 2 boxes with thermal insulation and 1 cleaning brush
- 1 box with boiler control unit and 1 bag with technical documentation
- 1 coding card and technical documentation for Vitoplex 200

5797333

Control unit versions

For a single boiler system

■ Vitotronic 100, type CC1E

For the control unit with a constant boiler water temperature.
For weather-compensated or room temperature-dependent operation in conjunction with an external control unit.

■ Vitotronic 200, type CO1E

For weather-compensated operation and mixer control for up to 2 heating circuits with mixer. For the 2 heating circuits with mixer, the accessory "Extension for heating circuits 2 and 3" is required.

For a multi boiler system (up to 8 boilers)

■ Vitotronic 300, type CM1E

For weather-compensated operation of a multi boiler system. This Vitotronic control unit also handles control of the boiler water temperature of a boiler within this multi boiler system.

Vitotronic 100, type CC1E and LON communication module

To control the boiler water temperature for each additional boiler in the multi boiler system.

■ Vitocontrol 100-M/200-M multi mode system controller

For weather-compensated cascade control of boilers with Vitotronic 100 control unit and a Vitobloc 200 CHP unit or other heat generators.

Multi mode system controller in the control panel

For single and multi boiler systems

Vitocontrol 100-M

■ For operation of multi mode heating systems with up to 4 heat generators, with various combinations of oil/gas boilers, heat pumps, CHP units and solid fuel boilers. The Vitocontrol 100-M can operate a range of defined standard schemes. The schemes are available via the Viessmann Schematic Browser. For the compatibility of the Vitocontrol 100-M in conjunction with Viessmann control units, see the compatibility list. Connection to Vitoscada for web-based system visualisation is available as an option. This requires an internet connection.

Viessmann Schematic Browser: www.viessmann-schemes.com

Compatibility list: www.vitoccontrol.info

Vitocontrol 200-M

■ For the operation of customer-specific multi mode energy systems with any number of heat generators in various combinations, as well as cooling, solar, ventilation and electricity components. Solutions are based on a modular system and can be flexibly extended with new functions and process applications. Connection to Vitoscada for web-based system visualisation is available as an option. This requires an internet connection.

Boiler accessories

See pricelist and "Boiler accessories" datasheet.

Operating conditions with Vitotronic boiler control units

For water quality requirements, see the technical guide to this boiler

		Requirements	
Operation with burner load		≥ 60 %	< 60 %
1.	Heating water flow rate	None	
2.	Boiler return temperature (minimum value) ^{*6}	– Oil operation 40 °C – Gas operation 53 °C	– Oil operation 53 °C – Gas operation 58 °C
3.	Lower boiler water temperature	– Oil operation 50 °C – Gas operation 60 °C	– Oil operation 60 °C – Gas operation 65 °C
4.	Two-stage burner operation	Stage 1: 60 % of rated heating output	No minimum load required
5.	Modulating burner operation	Between 60 and 100 % of rated heating output	No minimum load required
6.	Reduced mode	Single boiler systems and the lead boiler in multi boiler systems – Operation with lower boiler water temperature Lag boilers in multi boiler systems – Can be shut down	
7.	Weekend setback	As per reduced mode	

^{*6} A suitable system example showing the installation of a return temperature raising facility can be found in the technical guide "System examples".

Notes

Installing a suitable burner

Delivery without burner.

Suitable pressure-jet oil/gas burners are available from Weishaupt or ELCO and should be ordered separately (see pricelist). Delivery directly from Weishaupt or ELCO.

The material of the burner head must be suitable for operating temperatures of at least 500 °C.

Pressure-jet oil burner

The burner must be tested and designated to EN 267.

Pressure-jet gas burner

The burner must be tested to EN 676 and CE designated in accordance with Directive 2009/142/EC.

Burner adjustment

Adjust the oil or gas throughput of the burner to suit the rated boiler heating output.

Permissible flow temperatures

Hot water boiler for permissible flow temperatures (= safety temperatures)

- Up to 110 °C

CE designation:

CE-0085 in compliance with the Gas Appliances Directive

- Above 110 °C (up to 120 °C on request)

CE designation:

CE-0035 in compliance with the Pressure Equipment Directive

For operation with safety temperatures in excess of 110 °C additional safety equipment is required.

- Boilers with a safety temperature **above 110 °C** must be supervised in accordance with the Operational Safety Ordinance [Germany]. In accordance with conformity assessment diagram no. 5 of the Pressure Equipment Directive, these boilers must be classed as category IV.

The system must be tested prior to initial commissioning.

- Annually – external inspection (inspection of the safety equipment and water quality)

- Every 3 years – internal inspection (alternatively carry out a water pressure test)

- Every 9 years – water pressure test (for max. test pressure, see the type plate)

The test must be carried out by an approved inspection body (e.g. TÜV [in Germany]).

Further information on design/engineering

See the technical guide to this boiler.

Tested quality



CE designation according to current EC Directives



ÖVGW Quality Mark for gas and water equipment

Subject to technical modifications.

Viessmann Werke GmbH & Co. KG
D-35107 Allendorf
Telephone: +49 6452 70-0
Fax: +49 6452 70-2780
www.viessmann.com

Viessmann Limited
Hortonwood 30, Telford
Shropshire, TF1 7YP, GB
Telephone: +44 1952 675000
Fax: +44 1952 675040
E-mail: info-uk@viessmann.com

5797333