

4th EDITION

KOOLAIR



Technical Selection Guide

www.koolair.com

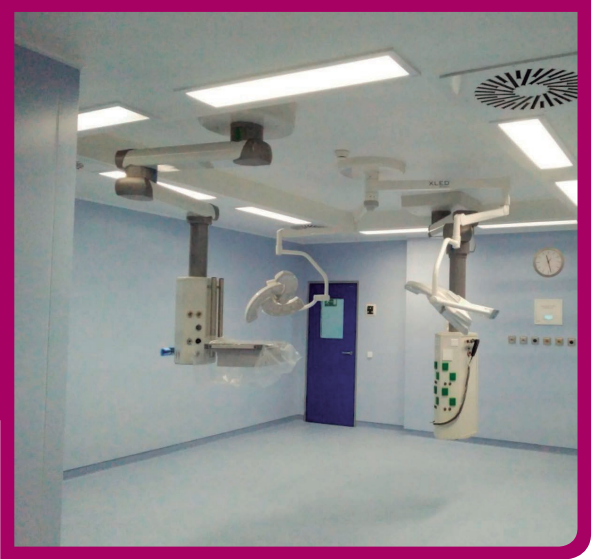

Technical selection guide



summary	5	Grilles
	41	Circular diffusers
	61	Swirl diffusers
	101	Long throw diffusers
	127	Square diffusers
	143	Linear slot diffusers
	173	Floor diffusers
	183	Fire dampers
	207	VAV/VAC
	227	Acoustic
	235	Air/Water
	249	Displacement diffusers
	263	Hospitals/Clean rooms
	275	More...

Grilles

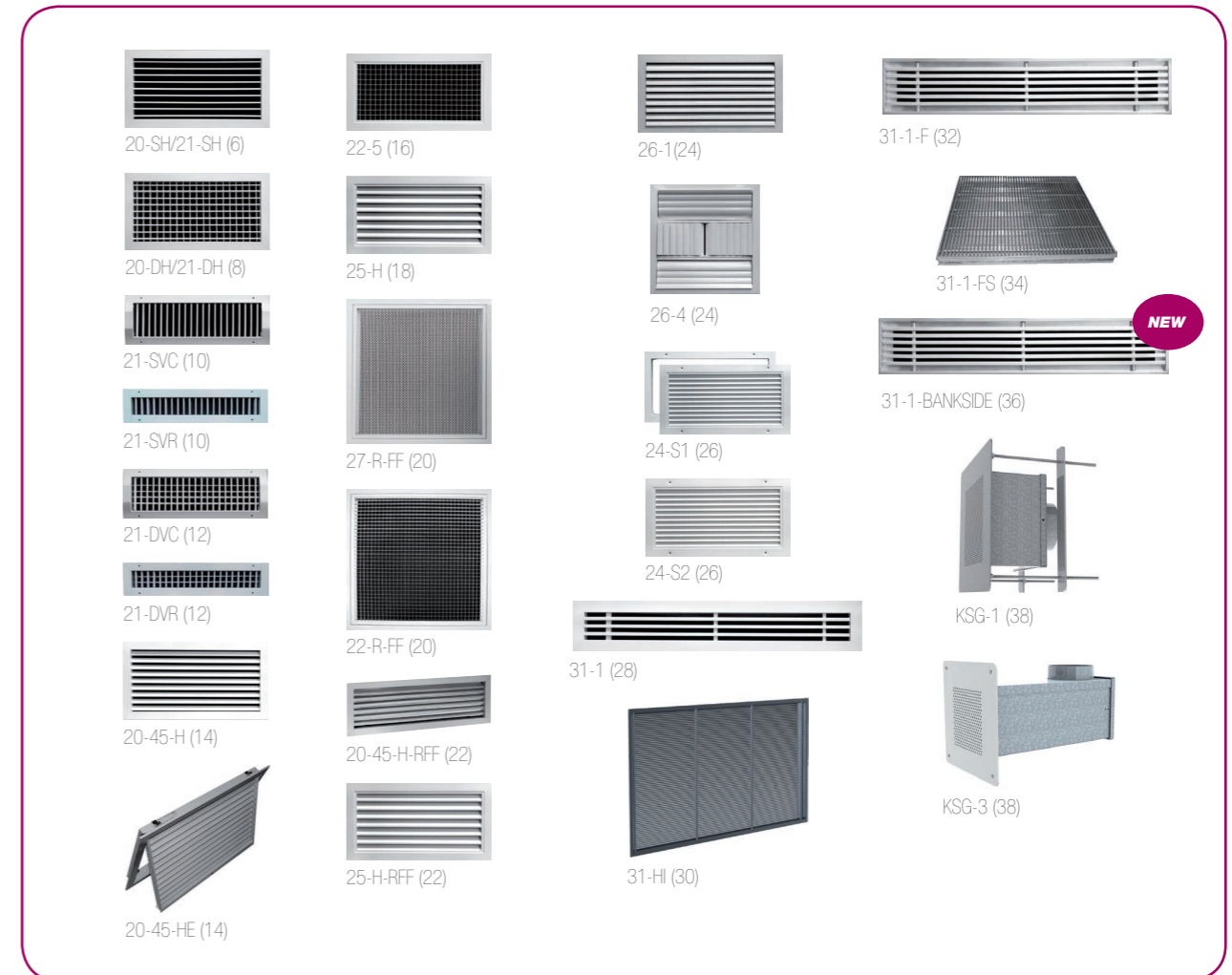

C.C. Nova Arcada (Braga – Portugal)

Grilles 20-SH, 20-DH, 24-S1 and 22-5,
extract valves GPD,
swirl diffusers DF-RO-C and DFRE-GR-TR,
overpressure dampers 230-SP,
long-throw diffuser DF-47,
intumescent grilles LVV-40
and fire dampers SFR and SFC.

20-SH/21-SH



Catalogue Series 20.1

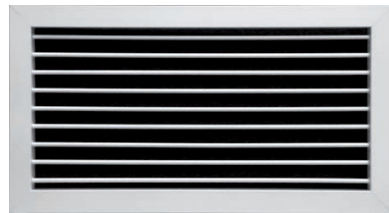

Single deflection grilles

Product description

Single deflection grille, KOOLAIR, model **20-SH**, of dimensions LxH, for supplying air with horizontal blades, individually adjustable.

It can incorporate volume control damper **(-O)** and fixation accessory to be determined.

Finished in anodised aluminium or any RAL colour upon request.

Other models

20-SV. Single deflection aluminium grille with vertical blades.

21-SH. Single deflection steel sheet grille with horizontal blades.

21-SV. Single deflection steel sheet grille with vertical blades.

Mounting

With pressure clips. Mounting frame needed **(-MM)**.

Concealed fixing **(-SFO)**. Mounting frame needed **(-MM)**.

With screws **(-T)**. Without indication, the grille is provided with holes for screwing the mounting frame.

With plenum box made of galvanised steel sheet, side or top entry connection **(-PE21/20)**.



General dimensions

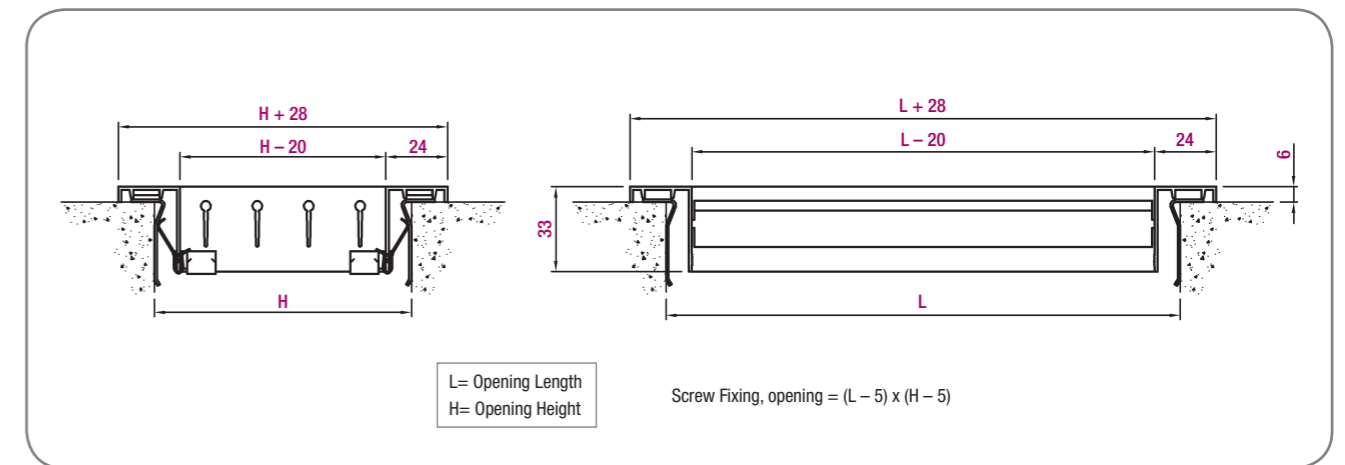

Selection table

Dimension	Q (m³/h)	L _{wa} [dB(A)]	ΔP _t (Pa)	X (m)	V _k (m/s)
200 x 100	170	24	7	2.5	3.9
	245	32	15	3.6	5.6
	350	40	31	5.2	7.9
300 x 100 200 x 150	240	24	7	2.9	3.6
	340	32	13	4.1	5.1
	500	40	29	6.1	7.6
300 x 150	330	24	6	3.3	3.3
	470	32	11	4.7	4.7
	670	40	23	6.7	6.8
600 x 100 400 x 150 300 x 200	420	24	5	3.6	3.2
	600	32	10	5.2	4.5
	870	40	22	7.5	6.6
500 x 150	500	24	5	3.8	3.0
	710	32	9	5.5	4.3
	1030	40	19	7.9	6.2
600 x 150 300 x 300	580	24	4	4.1	2.9
	840	32	9	5.9	4.2
	1215	40	19	8.5	6.1
600 x 200 500 x 250 400 x 300	770	24	4	4.5	2.7
	1110	32	8	6.5	4.0
	1600	40	16	9.4	5.7
1000 x 150 600 x 250 500 x 300	900	25	4	4.9	2.7
	1250	32	7	6.8	3.8
	1830	40	15	9.9	5.5
1100 x 200	1260	24	3	5.5	2.4
	1810	32	6	7.9	3.5
	2610	40	13	11.4	5.1
1200 x 250 1000 x 300	1615	24	3	6.0	2.3
	2325	32	5	8.7	3.3
	3360	40	11	12.5	4.8

The Selection Table shows a summary of dimensions. Other sizes available. Consult the Sales Department.



LEGEND

Q (m³/h): Air flow.
 L_{wa} [dB(A)]: Sound power level.
 ΔP_t (Pa): Total pressure loss.
 X (m): Throw for a maximum velocity of 0.25 m/s at the occupied zone
 ΔT = -10 °C (cold), installed at 2.7 m of height, with ceiling effect.
 V_k (m/s): Effective velocity.

20-DH/21-DH



Catalogue Series 20.1

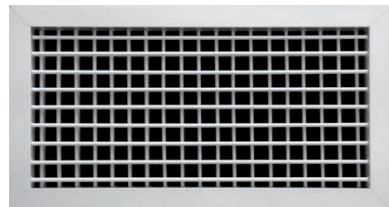

Double deflection grilles

Product description

Double deflection grille, KOOLAIR, model **20-DH**, of dimensions LxH, for supplying air with horizontal and vertical blades, individually adjustable. It can incorporate volume control damper **(-O)** and fixation accessory to be determined. Finished in anodised aluminium or any RAL colour upon request.

Other models

- 20-DV.** Double deflection grille, first blades in vertical position, made in aluminium.
- 21-DH.** Double deflection grille, first blades in horizontal position, made in steel sheet.
- 21-DV.** Double deflection grille, first blades in vertical position, made in steel sheet.

Mounting

With pressure clips. Mounting frame needed **(-MM)**.
 Concealed fixing **(-SFO)**. Mounting frame needed **(-MM)**.
 With screws **(-T)**. Without indication, the grille is provided with holes for screwing the mounting frame.
 With plenum box made of galvanised steel sheet, side or top entry connection **(-PE21/20)**.



General dimensions

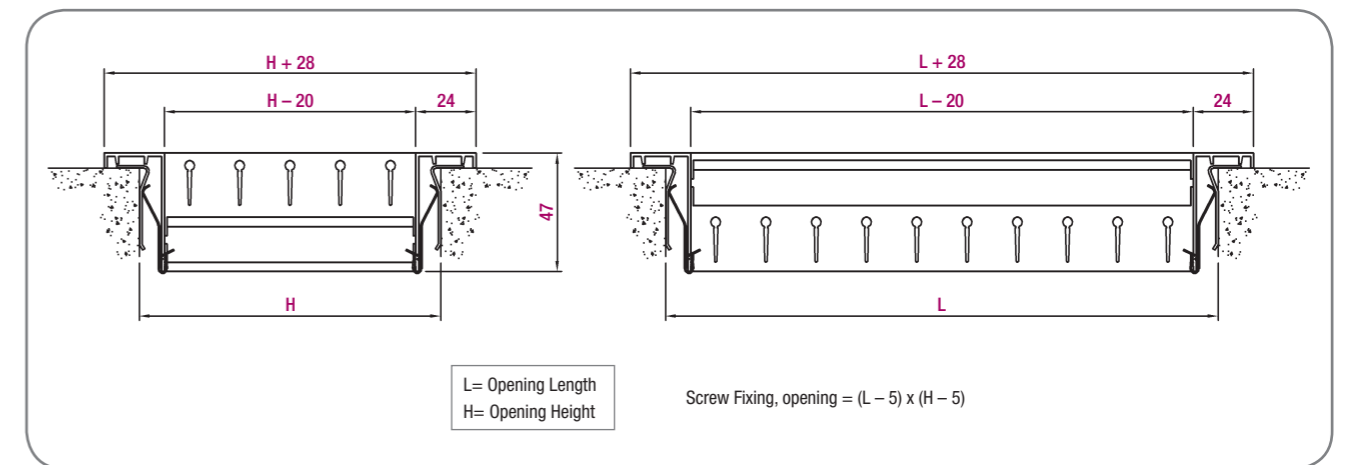

Selection table

Dimension	Q (m³/h)	L _{wa} [dB(A)]	ΔP _t (Pa)	X (m)	V _k (m/s)
200 x 100	160	24	8	2.7	4.5
	220	32	16	3.7	6.2
	310	40	31	5.2	8.8
300 x 100 200 x 150	220	24	7	3.0	4.2
	310	32	14	4.3	5.9
	430	40	26	5.9	8.1
300 x 150	310	24	6	3.5	3.9
	435	32	12	4.9	5.5
	600	40	23	6.8	7.6
600 x 100 400 x 150 300 x 200	390	24	5	3.8	3.7
	540	32	10	5.3	5.1
	760	40	21	7.4	7.2
500 x 150	460	24	5	4.0	3.5
	650	32	10	5.7	4.9
	910	40	19	7.9	6.9
600 x 150 300 x 300	540	24	5	4.3	3.4
	760	32	9	6.1	4.8
	1050	40	17	8.4	6.6
600 x 200 500 x 250 400 x 300	720	24	4	4.8	3.2
	1000	32	8	6.7	4.5
	1350	40	14	9.0	6.0
1000 x 150 600 x 250 500 x 300	800	24	4	4.9	3.0
	1120	32	7	6.9	4.2
	1550	40	14	9.6	5.9
1100 x 200	1150	24	3	5.7	2.8
	1625	32	6	8.0	3.9
	2260	40	12	11.2	5.5
1200 x 250 1000 x 300	1510	24	3	6.4	2.7
	2080	32	5	8.8	3.7
	2910	40	11	12.3	5.2

The Selection Table shows a summary of dimensions. Other sizes available. Consult the Sales Department.

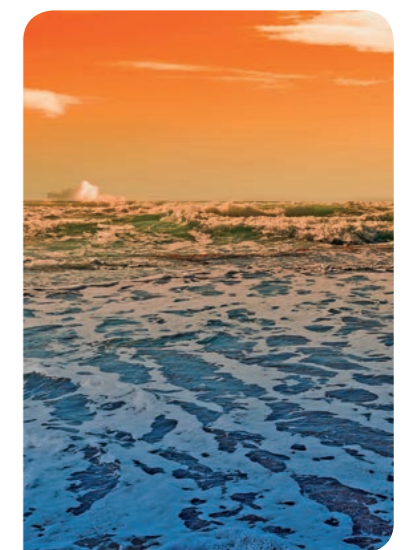

LEGEND

- Q (m³/h): Air flow.
- L_{wa} [dB(A)]: Sound power level.
- ΔP_t (Pa): Total pressure loss.
- X (m): Throw for a maximum velocity of 0.25 m/s at the occupied zone
- ΔT = -10 °C (cold), installed at 2.7 m of height, with ceiling effect.
- V_k (m/s): Effective velocity.

21-SVC/21-SVR



Catalogue Series 20.1

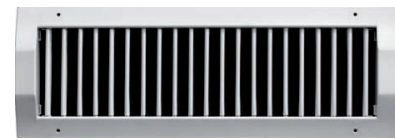

21-SVC



21-SVR



Single deflection grille for ducts

Product description

Single deflection grille for circular ducts, KOOLAIR, model **21-SVC**, of dimensions LxH, for supplying or returning air. It can incorporate volume control dampers (-RFS05/06).

Standard finished in steel sheet (-ZN) or any RAL colour upon request.

Other models

21-SVR. Single deflection grille for rectangular ducts.

Mounting

With screws (-T). The grille is provided with holes for screwing.

General dimensions

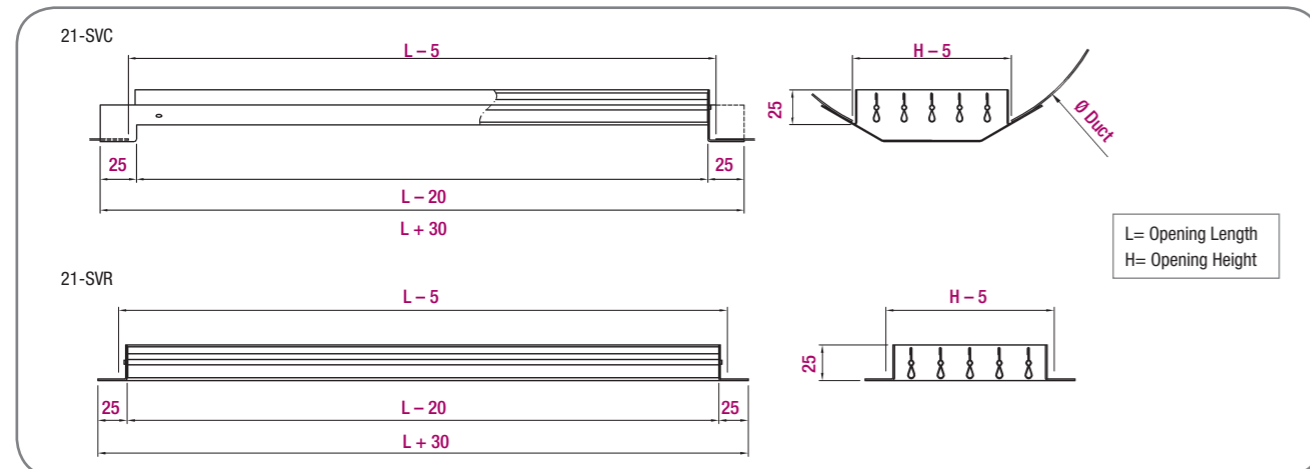

	Ø OF CIRCULAR DUCT			
	H mm			
	75	125	175	225
Ø MINIMUM mm	100	315	560	630
Ø MAXIMUM mm	400	900	1250	1400

Unit mm

Selection table

Dimension	Q (m³/h)	L _{wa} [dB(A)]	ΔP _t (Pa)	X (m)	V _k (m/s)
225 x 75	130	24	15	3.4	4.2
	190	32	29	4.9	6.0
	260	40	56	6.8	8.2
325 x 75	180	24	13	3.9	4.0
	250	32	25	5.5	5.5
	340	40	49	7.6	7.7
425 x 75	220	24	12	4.3	3.8
	310	32	23	5.9	5.2
	430	40	44	8.3	7.3
525 x 75	260	24	11	4.5	3.6
	370	32	21	6.3	5.0
	500	40	40	8.8	7.0
625 x 75	300	24	10	4.8	3.5
	420	32	20	6.7	4.9
	580	40	38	9.3	6.8
425 x 125	370	24	9	5.2	3.3
	520	32	18	7.2	4.6
	720	40	34	10.1	6.4
525 x 125	440	24	8	5.6	3.2
	620	32	16	7.7	4.4
	860	40	31	10.7	6.2
625 x 125	510	24	8	5.9	3.1
	710	32	15	8.2	4.3
	990	40	29	11.3	5.9
425 x 225	640	24	7	6.4	2.9
	890	32	14	8.9	4.0
	1240	40	26	12.3	5.6
525 x 225	770	24	6	6.8	2.8
	1060	32	12	9.5	3.9
	1480	40	24	13.2	5.4
625 x 225	880	24	6	7.2	2.7
	1230	32	12	10.0	3.7
	1710	40	22	13.9	5.2
825 x 225	1110	24	5	7.9	2.5
	1540	32	10	10.9	3.5
	2150	40	20	15.2	4.9
1025 x 225	1340	24	5	8.4	2.4
	1860	32	9	11.7	3.4
	2580	40	18	16.3	4.7



LEGEND

Q (m³/h): Air flow.
 L_{wa} [dB(A)]: Sound power level.
 ΔP_t (Pa): Total pressure loss.
 X (m): Throw for a maximum velocity of 0.25 m/s at the occupied zone
 ΔT = -10 °C (cold), installed at 2.7 m of height, with ceiling effect.
 V_k (m/s): Effective velocity.

The Selection Table shows a summary of dimensions. Other sizes available. Consult the Sales Department.

21-DVC/21-DVR



Catalogue Series 20.1



21-DVC



21-DVR



Double deflection grille for ducts

Product description

Double deflection grille for circular ducts, KOOLAIR, model **21-DVC**, of dimensions LxH, for supply and return air. It can incorporate volume control dampers (-RFS05 / 06). Standard finished in steel sheet (-ZN) or any RAL colour upon request.

Other models

21-DVR. Double deflection grille for rectangular ducts.

Mounting

With screws (-T). The grille is provided with holes for screwing.

General dimensions

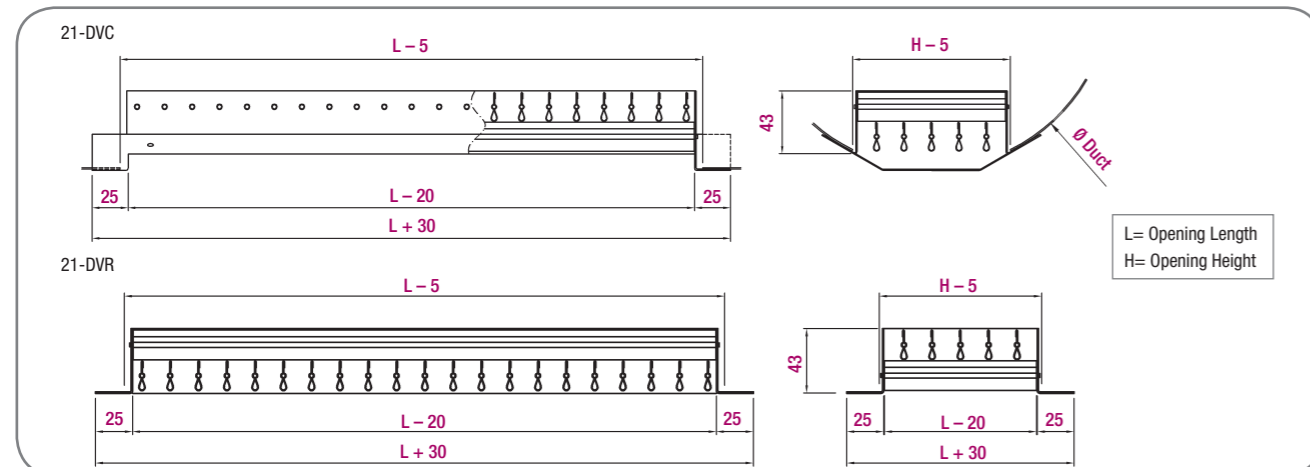

	Ø OF CIRCULAR DUCT			
	H mm			
	75	125	175	225
Ø MINIMUM mm	100	315	560	630
Ø MAXIMUM mm	400	900	1250	1400

Unit mm

Selection table

Dimension	Q (m³/h)	L _{wa} [dB(A)]	ΔP _t (Pa)	X (m)	V _k (m/s)
225 x 75	100	24	12	2.5	4.2
	140	32	22	3.5	5.8
	200	40	43	4.8	8.1
325 x 75	140	24	10	2.8	3.9
	190	32	19	3.9	5.4
	270	40	37	5.4	7.5
425 x 75	170	24	9	3.0	3.7
	240	32	17	4.2	5.1
	330	40	33	5.9	7.1
525 x 75	200	24	8	3.2	3.5
	280	32	16	4.5	4.9
	390	40	31	6.2	6.8
625 x 75	230	24	8	3.4	3.4
	320	32	15	4.7	4.8
	450	40	29	6.6	6.6
425 x 125	290	24	7	3.7	3.2
	410	32	13	5.1	4.5
	560	40	26	7.1	6.3
525 x 125	350	24	6	3.9	3.1
	480	32	12	5.5	4.3
	670	40	24	7.6	6.0
625 x 125	400	24	6	4.2	3.0
	560	32	11	5.8	4.2
	770	40	22	8.0	5.8
425 x 225	500	24	5	4.5	2.8
	700	32	10	6.3	4.0
	970	40	20	8.8	5.5
525 x 225	600	24	5	4.9	2.7
	830	32	9	6.7	3.8
	1150	40	18	9.4	5.3
625 x 225	690	24	5	5.1	2.6
	960	32	9	7.1	3.7
	1130	40	17	9.9	5.1
825 x 225	870	24	4	5.6	2.5
	1210	32	8	7.8	3.5
	1680	40	15	10.8	4.8
1025 x 225	1040	24	4	6.0	2.4
	1450	32	7	8.3	3.3
	2020	40	14	11.6	4.6



LEGEND

Q (m³/h): Air flow.
L_{wa} [dB(A)]: Sound power level.
ΔP_t (Pa): Total pressure loss.
X (m): Throw for a maximum velocity of 0.25 m/s at the occupied zone
ΔT = -10 °C (cold), installed at 2.7 m of height, with ceiling effect.
V_k (m/s): Effective velocity.

The Selection Table shows a summary of dimensions. Other sizes available. Consult the Sales Department.

20-45-H/21-45-H

Catalogue Series 20.2

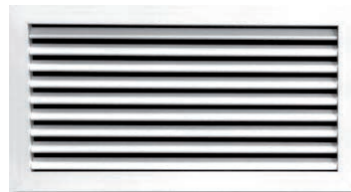

20-45-H



20-45-HE



Return grille

Product description

Return grille, KOOLAIR, **20-45-H** model, of dimensions LxH, for returning air, with horizontal fixed blades at 45°.

It can incorporate volume control damper (-O) and fixation accessory to be determined.

Finished in anodised aluminium or any RAL colour upon request.

Mounting

With pressure clips. Mounting frame needed (-MM).
Concealed fixing (-SFO). Mounting frame needed (-MM).

With screws (-T). Without indication, the grille is provided with holes for screwing the mounting frame.

With plenum box made of galvanised steel sheet, side or top entry connection (-PE21/20).

Other models

20-45-V. Return grille with vertical blades, fixed at 45°, made in aluminium.

21-45-H. Return grille with horizontal blades, fixed at 45°, made in steel sheet.

21-45-V. Return grille with vertical blades, fixed at 45°, made in steel sheet.

20-45-H-SB. Dimensions 595x295 - 595x595, for modular false ceilings.

20-45-H/V-FF. Grille with fixed horizontal or vertical blades at 45° with filterholder.

20-45-H/V-FL. Return grille with horizontal or vertical blades, fixed at 45°. Filter fixed to the grill through clip on the rear.

20-45-HE. Grilles with horizontal blade pack, hinged on fixed frame with lock and key.

General dimensions

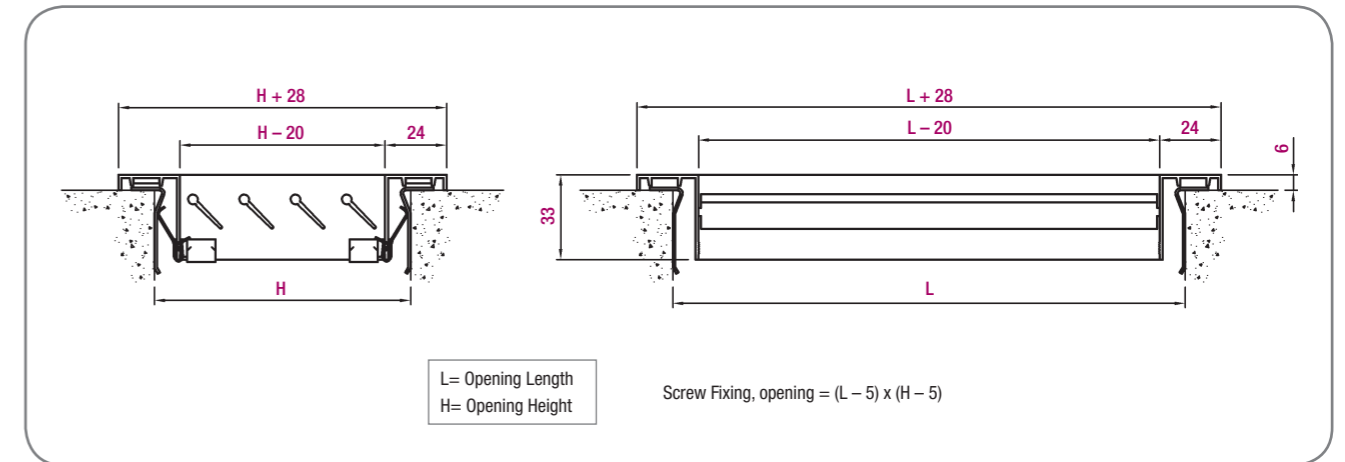

Selection table

Dimension	Q (m³/h)	L _{WA} [dB(A)]	ΔP _t (Pa)	V _k (m/s)
200 x 100	70	24	6	2.4
	90	32	12	3.4
	120	40	22	4.6
250 x 100	80	24	6	2.4
	110	32	11	3.2
	150	40	20	4.3
300 x 100	100	24	5	2.2
	130	32	10	3.0
	180	40	19	4.1
400 x 100	130	24	5	2.1
	170	32	9	2.9
	230	40	17	3.9
600 x 100	190	24	4	2.0
	250	32	8	2.7
	340	40	14	3.7
400 x 200	230	24	4	1.8
	310	32	7	2.5
	420	40	13	3.4
450 x 200	280	24	4	1.9
	380	32	7	2.6
	520	40	12	3.6
500 x 200	350	24	3	2.1
	470	32	6	2.8
	640	40	11	3.8
600 x 200	400	24	3	2.0
	550	32	6	2.7
	750	40	11	3.7
800 x 200	520	24	3	2.0
	700	32	5	2.7
	950	40	10	3.7

Dimension	Q (m³/h)	L _{WA} [dB(A)]	ΔP _t (Pa)	V _k (m/s)	
1000 x 200	620	24	3	1.9	
	840	32	5	2.5	
	1140	40	9	3.5	
300 x 300	330	24	3	2.2	
	450	32	6	3.0	
	660	40	13	4.4	
800 x 300	780	24	2	1.8	
	1060	32	4	2.5	
	1440	40	8	3.4	
1000 x 300	940	24	2	1.8	
	1270	32	4	2.4	
	1740	40	8	3.3	
1200 x 300	1180	24	2	1.9	
	1600	32	4	2.5	
	2180	40	7	3.4	
900 x 400	1600	32	4	2.5	
	700 x 500	2180	40	7	3.4
	600 x 600				

LEGEND

Q (m³/h): Air flow.

L_{WA} [dB(A)]: Sound power level.

ΔP_t (Pa): Total pressure loss.

V_k (m/s): Effective velocity.

The Selection Table shows a summary of dimensions. Other sizes available. Consult the Sales Department.

22-5



Catalogue Series 20.2

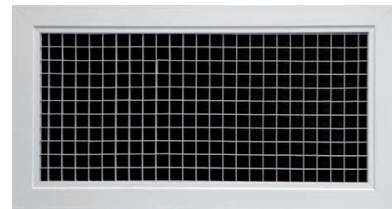

Egg crate grilles for return

Product description

Egg crate grille, KOOLAIR, model **22-5**, of dimensions LxH, for returning air. It can incorporate volume control damper **(-O)**, fixation accessory to be determined. Finished in anodised aluminium or any RAL colour upon request.

Other models

22-5-I. Egg crate grille, blades at 45°.
22-5-SB. Dimensions 595x295 - 595x595, for modular false ceiling.

Mounting

With pressure clips. Mounting frame needed **(-MM)**.
 Concealed fixing **(-SFO)**. Mounting frame needed **(-MM)**.
 With screws **(-T)**. Without indication, the grille is provided with holes for screwing the mounting frame.
 With plenum box made of galvanised steel sheet, side or top entry connection **(-PE21/20)**.



General dimensions

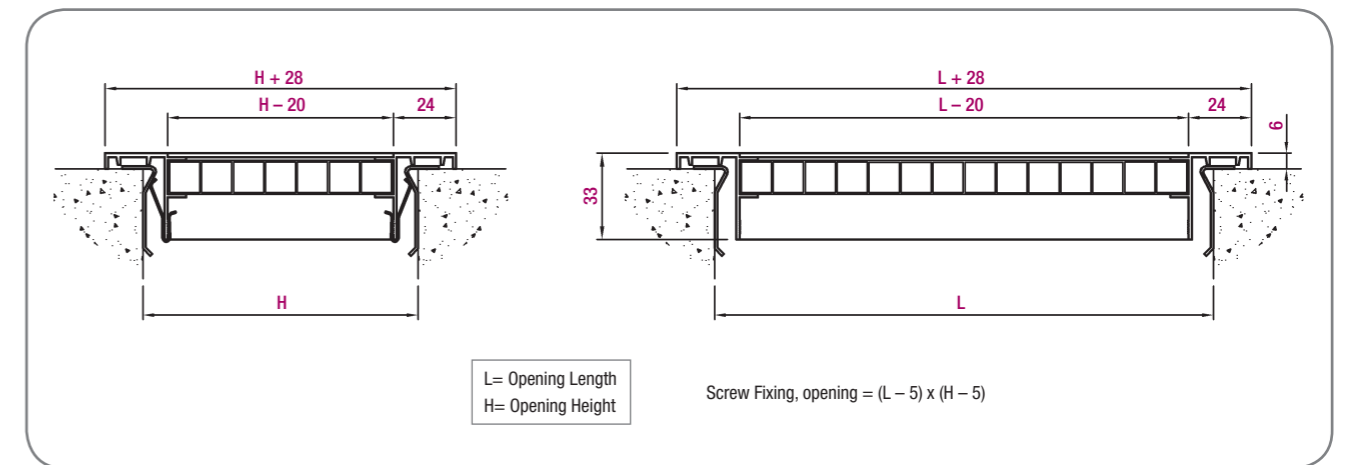

Selection table

Dimension	Q (m³/h)	L _{wa} [dB(A)]	ΔP _t (Pa)	V _k (m/s)
200 x 200	320	24	13	2.9
400 x 100	430	32	24	3.8
	580	40	42	5.1
250 x 250	450	24	11	2.6
300 x 200	610	32	19	3.5
400 x 150	820	40	35	4.6
350 x 350	810	24	8	2.2
400 x 300	1090	32	14	2.9
600 x 200	1460	40	25	3.9
450 x 450	1230	24	6	1.9
500 x 400	1650	32	11	2.6
700 x 300	2210	40	19	3.5
600 x 600	1980	24	5	1.7
900 x 400	2650	32	8	2.3
1000 x 350	3550	40	15	3.0
700 x 700	2530	24	4	1.6
800 x 600	3390	32	7	2.1
1000 x 500	4540	40	13	2.8
1300 x 500	3130	24	3	1.5
1200 x 600	4190	32	6	2.0
800 x 800	5620	40	11	2.6
1600 x 500	3770	24	3	1.4
1350 x 600	5050	32	6	1.9
900 x 900	6770	40	10	2.5
1650 x 600	4450	24	3	1.3
1250 x 800	5970	32	5	1.8
1000 x 1000	8000	40	9	2.4

The Selection Table shows a summary of dimensions. Other sizes available. Consult the Sales Department.



LEGEND

Q (m³/h): Air flow.
 L_{wa} [dB(A)]: Sound power level.
 ΔP_t (Pa): Total pressure loss.
 V_k (m/s): Effective velocity.

25-H



Catalogue Series 20.2



External grilles or return air

Product description

Return grille, louvres for exterior air intake or exhaust, KOOLAIR, model **25-H**, of dimensions LxH, with horizontal blades fixed at 45°. It can incorporate volume control damper (-O) and anti-insect mesh (-MI). Finished in anodised aluminium or any RAL colour upon request.

General dimensions

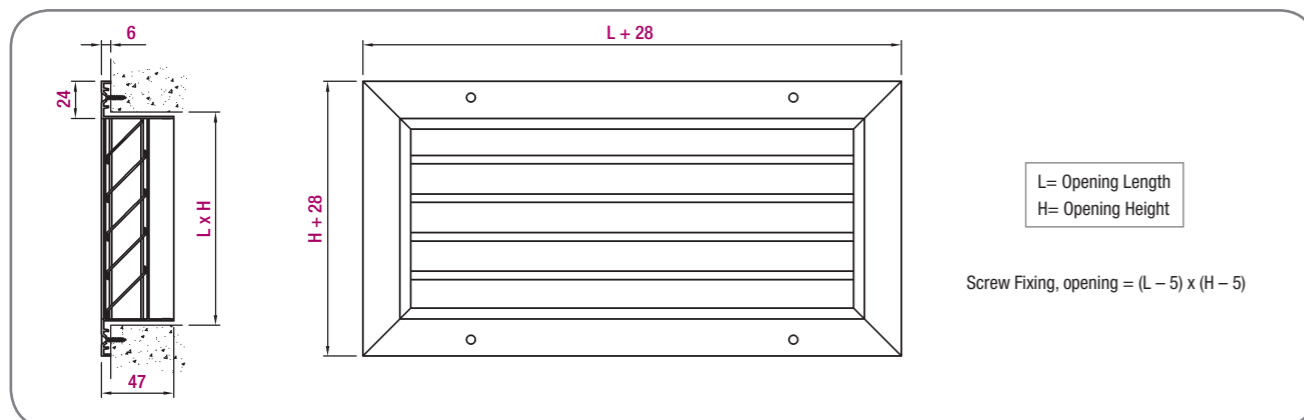

Other models

25-H-SB. Dimensions 595x295 - 595x595, for modular false ceilings.

Mounting

With pressure clips. Mounting frame needed (-MM).
With screws (-T). Without indication, the grille is provided with holes for screwing the mounting frame.
With plenum box made of galvanised steel sheet, side or top entry connection (-PE21/20).

Selection table

Dimension	Q (m³/h)	L _{wa} [dB(A)]	ΔP _t (Pa)	V _k (m/s)
200 x 100	42	24	8	2,2
	58	32	14	3,0
	82	40	29	4,2
250 x 100	52	24	7	2,1
	70	32	13	2,9
	100	40	27	4,1
300 x 100 200 x 150	60	24	7	2,1
	84	32	13	2,9
	115	40	25	3,9
400 x 100 200 x 200	77	24	6	2,0
	107	32	12	2,8
	148	40	23	3,8
500 x 100 250 x 200	94	24	6	1,9
	130	32	12	2,7
	175	40	21	3,6
600 x 100 400 x 150 300 x 200	140	24	5	1,8
	190	32	10	2,4
	260	40	18	3,3
500 x 150 400 x 200 300 x 250	170	24	5	1,7
	230	32	9	2,4
	320	40	18	3,3
600 x 150 450 x 200	200	24	5	1,7
	270	32	9	2,3
	370	40	16	3,2
600 x 200 400 x 300	275	24	4	1,6
	380	32	8	2,2
	520	40	15	3,0
800 x 200 400 x 400	360	24	4	1,6
	495	32	7	2,1
	685	40	14	3,0
1000 x 300 750 x 400	680	24	3	1,4
	930	32	6	1,9
	1290	40	11	2,6
900 x 400 600 x 600	850	24	3	1,3
	1160	32	5	1,8
	1650	40	11	2,5
1000 x 600	1340	24	2	1,2
	1840	32	5	1,7
	2540	40	9	2,4



LEGEND

Q (m³/h): Air flow.
L_{wa} [dB(A)]: Sound power level.
ΔP_t (Pa): Total pressure loss.
V_k (m/s): Effective velocity.

The Selection Table shows a summary of dimensions. Other sizes available. Consult the Sales Department.

27-R-FF/22-R-FF

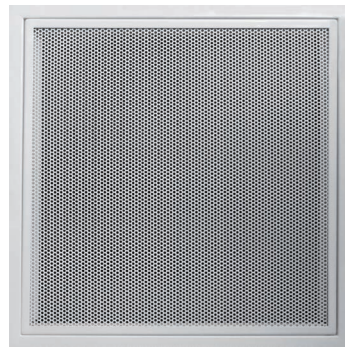

27-R-FF



22-R-FF



Special filterholder grilles, ceiling application

Product description

Hinged filterholder grilles, specifically for modular ceilings. Standard white (RAL 9010) finish. Can include a plenum with lateral connection. (Not including filter, thickness 13 mm).

27-R-FF. Steel plate grille with circular perforation of $\text{Ø}4.8$ mm – step 6.35 mm.

22-R-FF. Egg crate grille made of aluminium.

Other models

22-I-R-FF. Hinged filterholder egg crate grille with inclined blade pack at 45° made in aluminium.



General dimensions

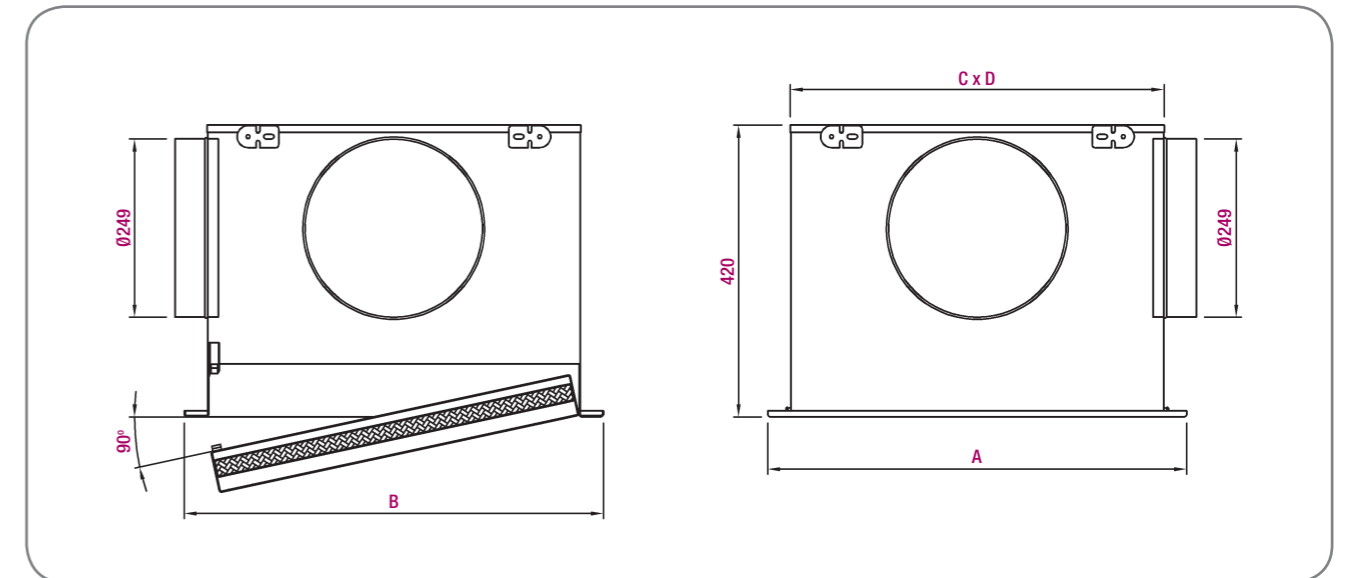

Possibility of manufacturing plenum with a lateral or top connection to suit available height in false ceiling and flow rate per grille.

Dimensions

Model	A	B	C	D
600 x 300	595	295	554	254
600 x 600	595	595	554	554
675 x 675	670	670	629	629

Unit mm

Selection table 27-R-FF

Dimension	Q (m ³ /h)	L _w -dB(A)	P _{st} (Pa)
600 x 300	565	24	25
	720	32	40
	920	40	63
600 x 600	1130	24	20
	1435	32	33
	1835	40	53
675 x 675	1410	24	19
	1800	32	32
	2300	40	49

Selection table 22-R-FF

Dimension	Q (m ³ /h)	L _w -dB(A)	P _{st} (Pa)
600 x 300	1045	24	24
	1400	32	41
	1875	40	65
600 x 600	2010	24	19
	2695	32	31
	3610	40	47
675 x 675	2470	24	19
	3310	32	29
	4440	40	47

LEGEND

Q (m³/h): Air flow.

L_w-dB(A): Sound power level (grille with plenum).

P_{st} (Pa): Pressure drop (grille with plenum and without filter).

20-45-H-RFF/25-H-RFF

Filterholder grilles

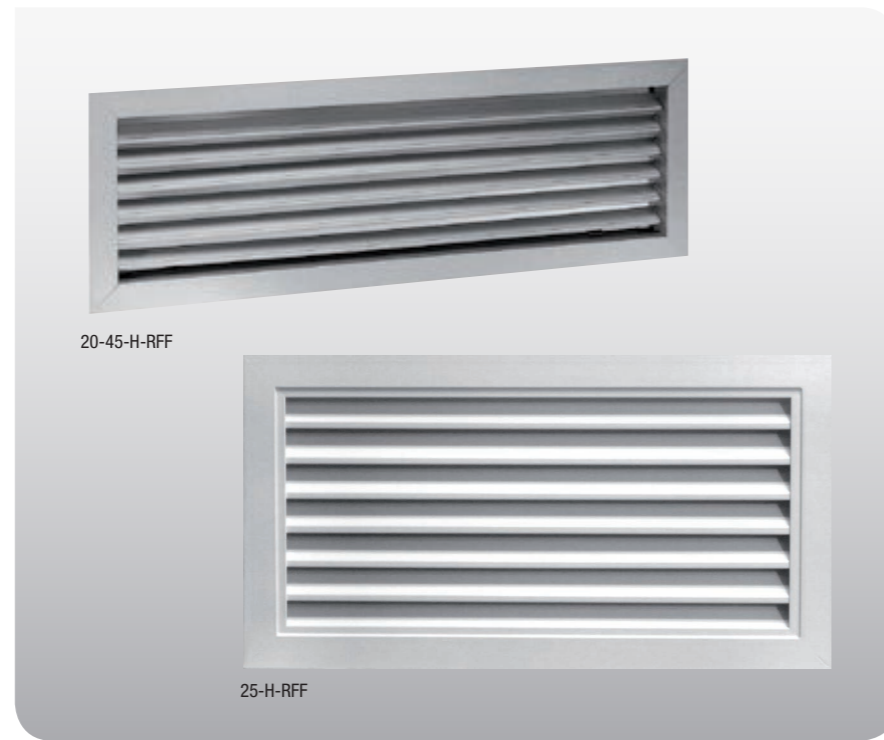

Product description

Hinged filterholder grilles for special application on both walls and ceilings. Natural anodized aluminum finish (filter not included). Upon enquiry and by special order, the component can be supplied with volume control damper (-O).

On demand filter thickness 10 mm.

Other models

20-45-H-RFF. Filterholder grille with fixed horizontal vanes at 45°.

25-H-RFF. Filterholder grille, air intake and exhaust, with fixed horizontal blades at 45°.



General dimensions

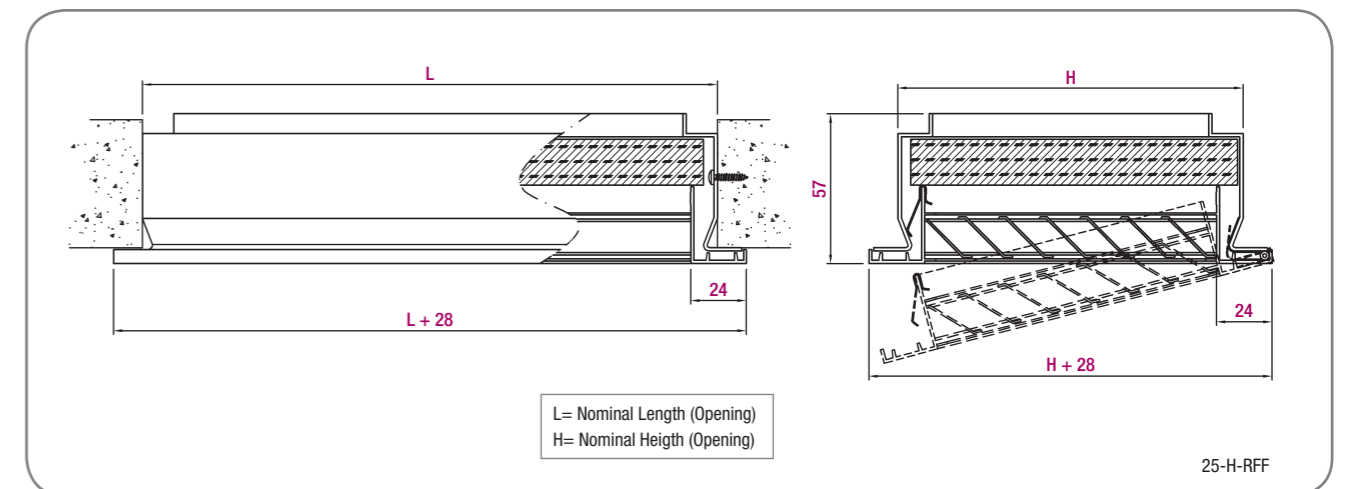
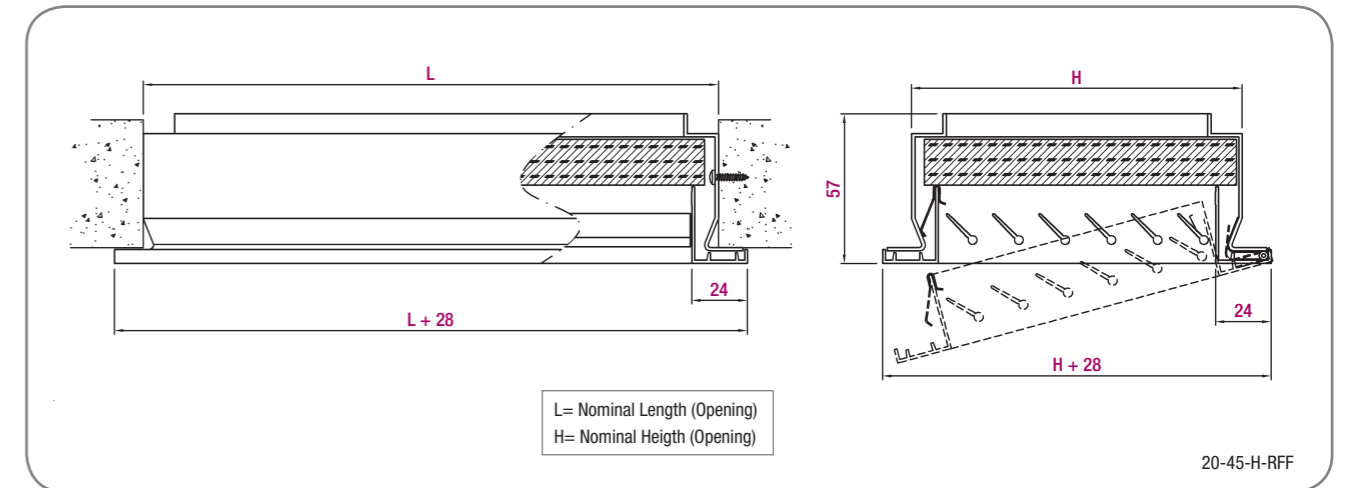

Selection table 20-45-H-RFF

Dimension	Q (m³/h)	L _w -dB(A)	P _{st} (Pa)
600 x 300	650	25	3
	950	35	7
	1400	45	15
600 x 600	1250	25	2
	1800	35	6
	2600	45	12

LEGEND

Q (m³/h): Air flow.

L_w-dB(A): Sound power level.

P_{st} (Pa): Pressure drop. Values with plenum.

Data does not include filter.

Selection table 25-H-RFF

Dimension	Q (m³/h)	L _w -dB(A)	P _{st} (Pa)
600 x 300	450	25	5
	700	35	11
	1000	45	22
600 x 600	880	25	4
	1300	35	8
	2000	45	19

Data does not include filter.



26-1



26-4



Curved-blade supply grilles

Product description

The curved-blade grilles, KOOLAIR **26** model, of LxH dimensions specially designed to provide any type of discharge: from absolute horizontal to total verticality, whether ceiling- or wall-mounted. Supplied in 1, 2, 3 and 4 airflow directions. Can include volume control damper **(-O)**. Natural anodized aluminum finish (uncoated).

Other models

- 26-1.** Curved-blade grille, 1-way air discharge.
- 26-2.** Curved-blade grille, 2-way air discharge.
- 26-3.** Curved-blade grille, 3-way air discharge.
- 26-4.** Curved-blade grille, 4-way air discharge.

Mounting

With pressure clips. Mounting frame needed **(-MM)**. Concealed fixing **(-SFO)**. Mounting frame needed **(-MM)**.
 With screws **(-T)**. Without indication, the grille is provided with holes for screwing the mounting frame.
 With plenum box made of galvanised steel sheet, side or top entry connection **(-PE21/20)**.



General dimensions

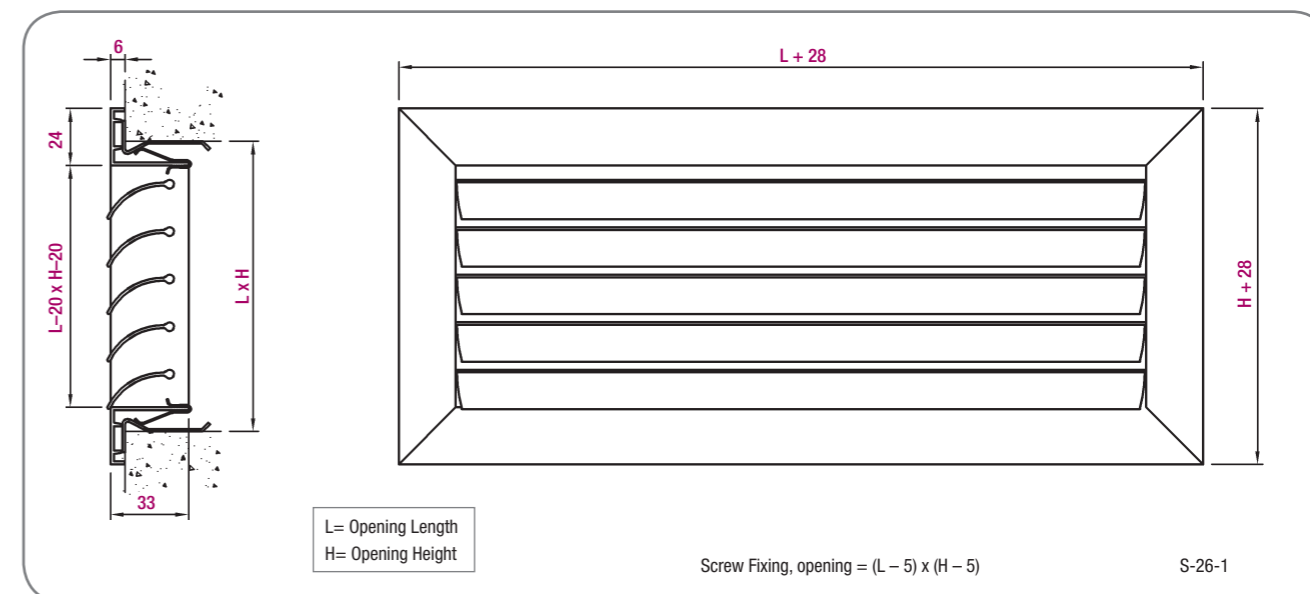

Selection table

Dimension	Q (m³/h)	L _{wa} [dB(A)]	ΔP _t (Pa)	X (m)
150 x 150	100	24	10	2.5
	120	32	14	3.6
	155	40	23	5.2
200 x 200	160	24	8	2.8
	180	32	10	4.0
	240	40	18	5.8
250 x 250	220	24	6	3.5
	280	32	10	5.0
	350	40	16	7.3
300 x 300	295	24	5	3.2
	350	32	8	4.6
	470	40	14	6.6
400 x 400	470	24	4	3.8
	550	32	6	5.4
	740	40	11	7.8
600 x 300	525	24	4	4.0
	700	32	7	5.8
	830	40	10	8.3
500 x 500	680	24	4	4.7
	800	32	5	6.8
	1.050	40	9	9.7
600 x 600	890	24	3	4.4
	1.050	32	4	6.4
	1.400	40	8	9.2

The Selection Table shows a summary of dimensions. Other sizes available. Consult the Sales Department.



LEGEND

Q (m³/h): Air flow.
 L_{wa} [dB(A)]: Sound power level.
 ΔP_t (Pa): Total pressure loss.
 Y (m): Throw for a maximum velocity of 0.25 m/s at the occupied zone DT=-10°C (cold), installed at 3 m of height, with ceiling effect.

24-S1/24-S2



Catalogue Series 20.2



24-S1



24-S2



Door grilles

Product description

Grille mounted in door for air transfer with fixed blades in V, KOOLAIR, model **24-S1** with counterframe, of dimensions LxH.

This type of grille is always delivered with a mounting frame, provided with holes for screwing (-T).

The arrangement of the S-24 blades in inverted "V", impedes vision through it when applied in doors, partition,walls.

Recommended transfer velocity for selection is from 0,75 to 1,25 m/s

For grille type 24-S1 (with counterframe) installation is recommended in walls with upto 50 mm thickness. Finished in anodised aluminium in its natural colour.

Other models

24-S2. Grille mounted in door for air transfer with fixed blades in V without counterframe.

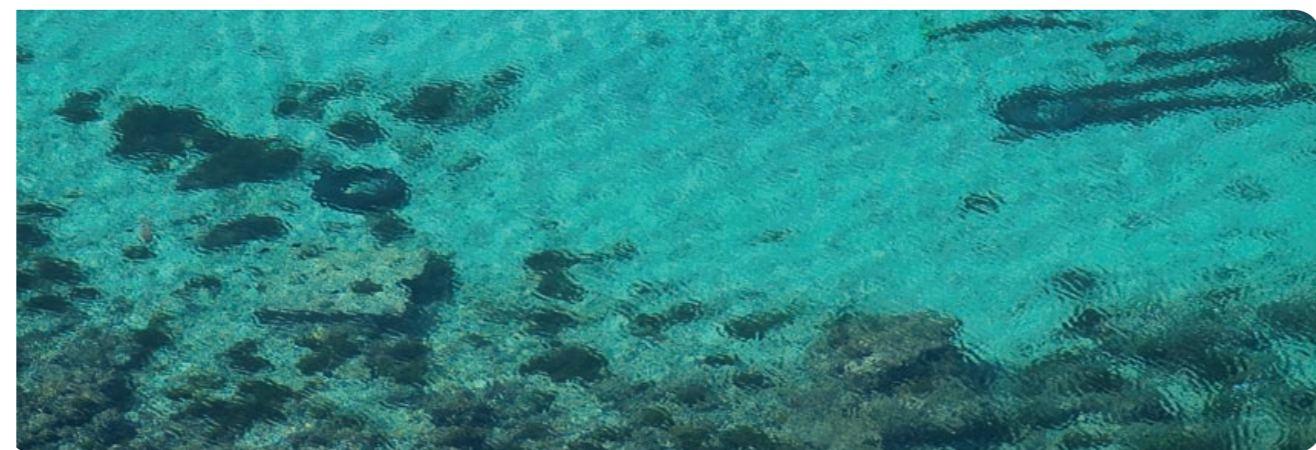

General dimensions

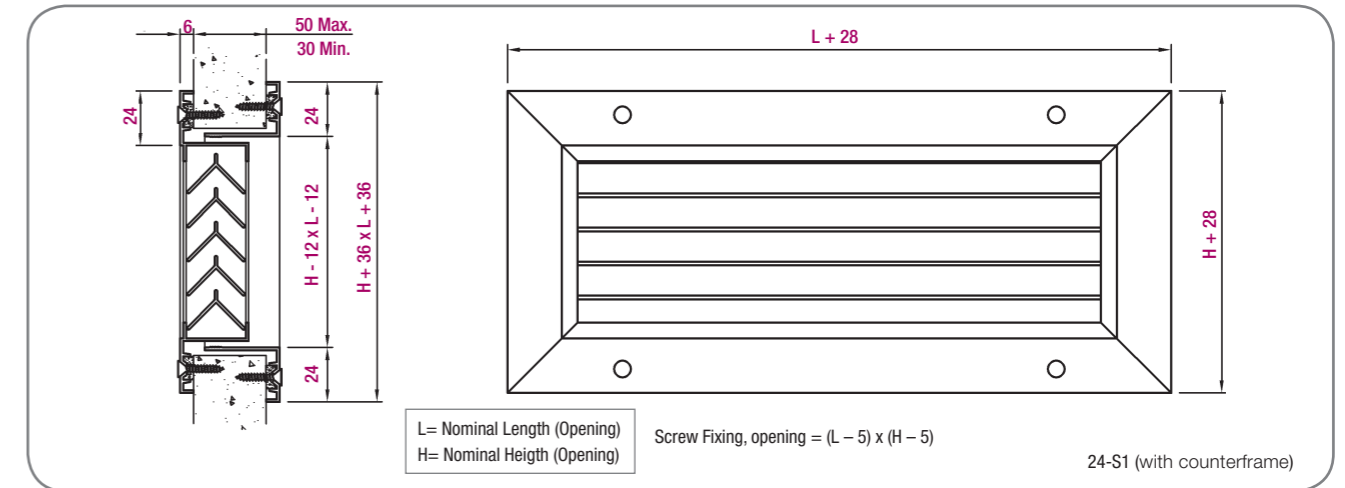

24-S1 (with counterframe)

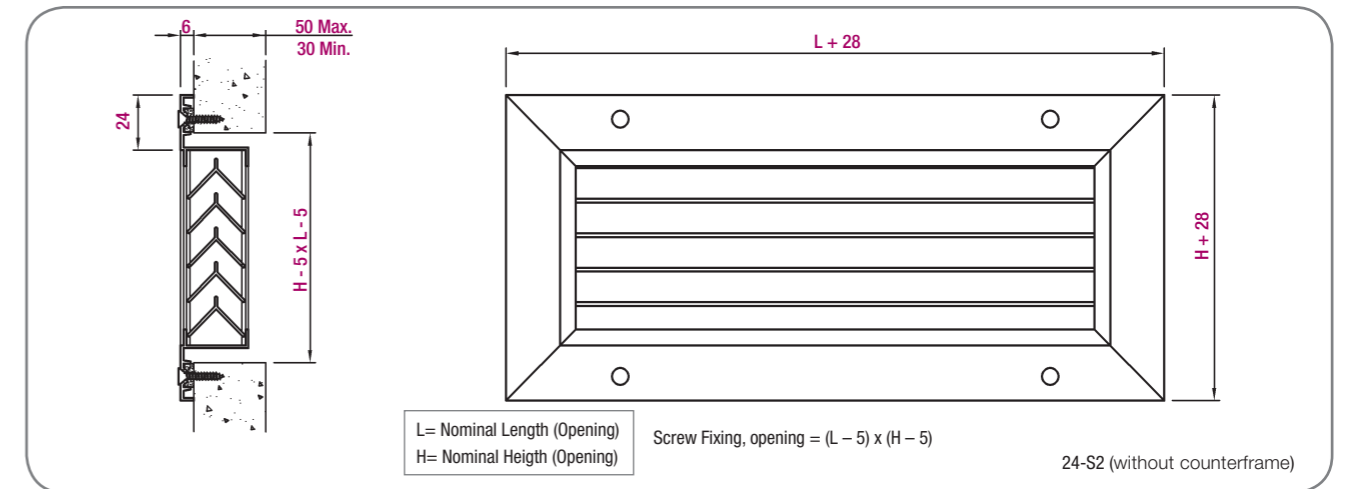

24-S2 (without counterframe)

Selection table 24-S1/24-S2

Dimension	Q (m³/h)	L _{wA} [dB(A)]	ΔP _t (Pa)	V _k (m/s)
300 x 100	45	20	3	0,8
	60	26	6	1,1
	75	32	9	1,3
400 x 100	60	20	3	0,8
	75	26	5	1,0
	100	32	9	1,3
500 x 150	115	20	3	0,8
	145	26	5	1,0
	185	32	9	1,3
400 x 200	130	20	3	0,8
	165	26	5	1,0
	210	32	8	1,3
500 x 200	165	20	3	0,8
	210	26	5	1,0
	265	32	8	1,3

Dimension	Q (m³/h)	L _{wA} [dB(A)]	ΔP _t (Pa)	V _k (m/s)
600 x 200	220	20	3	0,8
	255	26	5	1,0
	325	32	9	1,3
600 x 250	250	20	3	0,8
	315	26	5	1,0
	400	32	8	1,3
600 x 350	350	20	3	0,8
	450	26	5	1,0
	570	32	8	1,3
700 x 400	475	20	3	0,8
	610	26	5	1,0
	775	32	8	1,3

LEGEND

Q (m³/h): Air flow.

L_w-dB(A): Sound power level.

Pst (Pa): Pressure drop.

V_k (m/s): Effective velocity.

The Selection Table shows a summary of dimensions. Other sizes available. Consult the Sales Department.



Linear bar grille



Product description

Linear grille for supplying or returning air, KOOLAIR, model **31-1** of dimensions LxH, with horizontal fixed blades at 0°. It can incorporate volume control damper **(-O)** and fixation accessory to be determined. Finished in anodised aluminium or any RAL colour upon request.

Note: Possible to form continuous lines (Maximum length per section 2000 mm).

Mounting

- With pressure clips. Mounting frame needed **(-MM)**.
- With fixing straps for filter **(-FL)**.
- With screws **(-T)**. The grille is provided with holes for screwing the mounting frame.
- With plenum box made of galvanised steel sheet, with side or top spigot connection **(-PE21/20)**.
- Concealed fixing **(-SFO)**. Mounting frame needed **(-MM)**.

Other models

- 31-15.** Linear bar grille with fixed blades (deflection 15°).
- 31-1/15-G.** Linear bar grille with fixed blades (deflection 0° or 15°), secondary deflection with vertical blades.
- 31-1/15-20.** Linear bar grille with fixed blades (deflection 0° or 15°), with fine frame of 20x1,5 mm.
- 31-1/15-G-20.** Linear bar grille with fixed blades (deflection 0° or 15°), secondary deflection with vertical blades and fine frame of 20x1,5 mm.
- 31-1/15-E-PM.** Linear bar grille with fixed blades (deflection 0° or 15°), with narrow frame of 8,7 mm and mounting bridge.
- 31-1/15-SB.** Linear bar grill with fixed blades (deflection 0° or 15°), without frame.
- 31-1/15-11.** Linear bar grille with fixed blades (deflection 0° or 15°), with frame of 11x6 mm.
- 31-1/15-6.** Linear bar grille with fixed blades (deflection 0° or 15°), with frame of 6,6 mm.
- 31-1/15 SPORT.** The ball protection linear bar grilles are used for supply and extract, in gym, sport centres and multi-purpose halls.

General dimensions

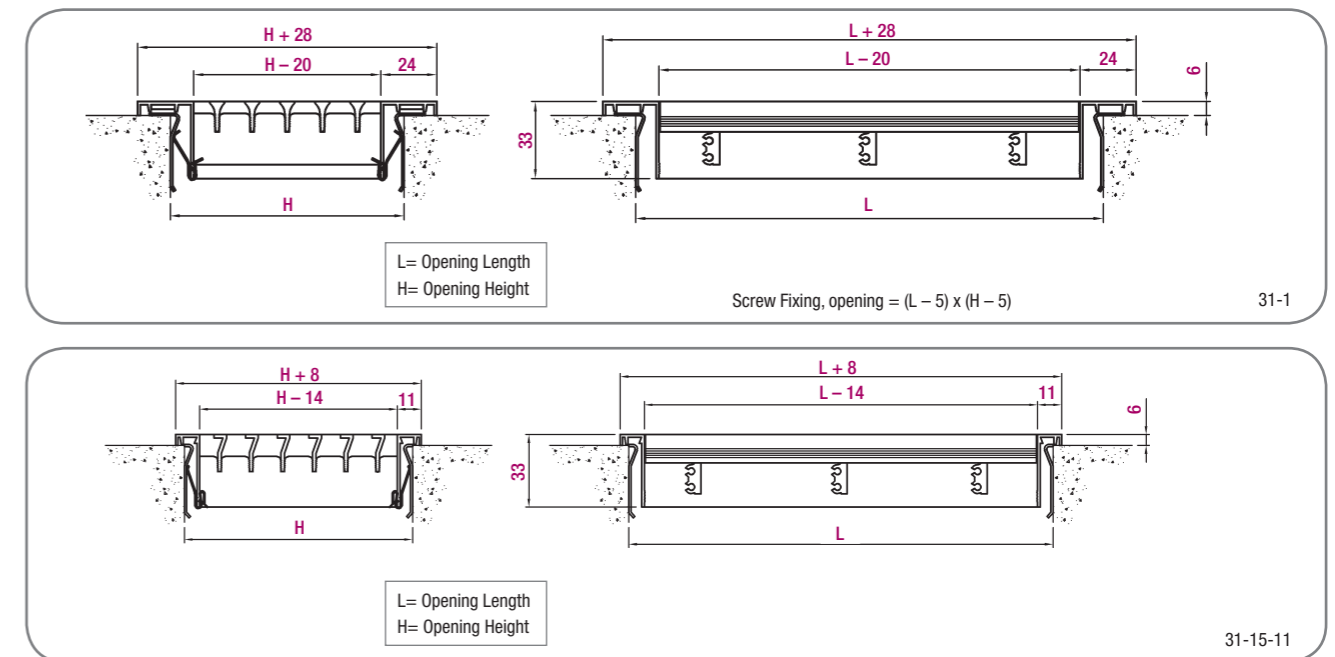

Selection table

(Flow rate per linear metre of grille)

Dimension	Q (m³/h)	L _{wa} [dB(A)]	ΔP _t (Pa)	X (m)	V _k (m/s)
1000 x 50	260	24	5	2,7	3,0
	350	32	10	3,7	4,1
	490	40	18	5,0	5,6
1000 x 75	390	24	5	3,1	2,8
	510	32	8	4,2	3,8
	700	40	16	5,8	5,2
1000 x 100	480	24	4	3,4	2,7
	650	32	8	4,6	3,6
	890	40	14	6,3	4,9
1000 x 125	610	24	4	3,7	2,5
	840	32	7	5,2	3,5
	1150	40	13	7,1	4,7
1000 x 150	710	24	3	4,0	2,4
	970	32	6	5,4	3,3
	1330	40	12	7,4	4,6
1000 x 200	900	24	3	4,4	2,3
	1240	32	6	6,0	3,2
	1690	40	11	8,2	4,3
1000 x 250	1140	24	3	4,8	2,2
	1560	32	5	6,6	3,0
	2130	40	10	9,0	4,2
1000 x 300	1330	24	3	5,1	2,2
	1810	32	5	7,0	2,9
	2480	40	9	9,6	4,0

The Selection Table shows a summary of dimensions. Other sizes available. Consult the Sales Department.



LEGEND

- Q (m³/h): Air flow.
- L_{wa} [dB(A)]: Sound power level.
- ΔP_t (Pa): Total pressure loss.
- X (m): Throw for a maximum velocity of 0.25 m/s at the occupied zone
- ΔT = -10 °C (cold), installed at 2.7 m of height, with ceiling effect.
- V_k (m/s): Effective velocity.

31-HI



Catalogue Series 30



High-induction linear bar grille

Product description

High induction linear grille for supplying or returning air, KOOLAIR, model **31-HI** of dimensions LxH, with horizontal fixed blades at 5° or 15° deflection (reversible core). It can incorporate volume control damper **(-O)** and fixation accessory to be determined.

Finished in anodised aluminium or any RAL colour upon request.

Other models

31-HI-G. Linear bar grille with fixed blades (deflection 5° or 15°), with secondary deflection.

Mounting

With pressure clips. Mounting frame needed **(-MM)**.

With screws **(-T)**. The grille is provided with holes for screwing the mounting frame.

With plenum box made of galvanised steel sheet, with side or top spigot connection **(-PE21/20)**.

PM. With mounting bridge.



General dimensions

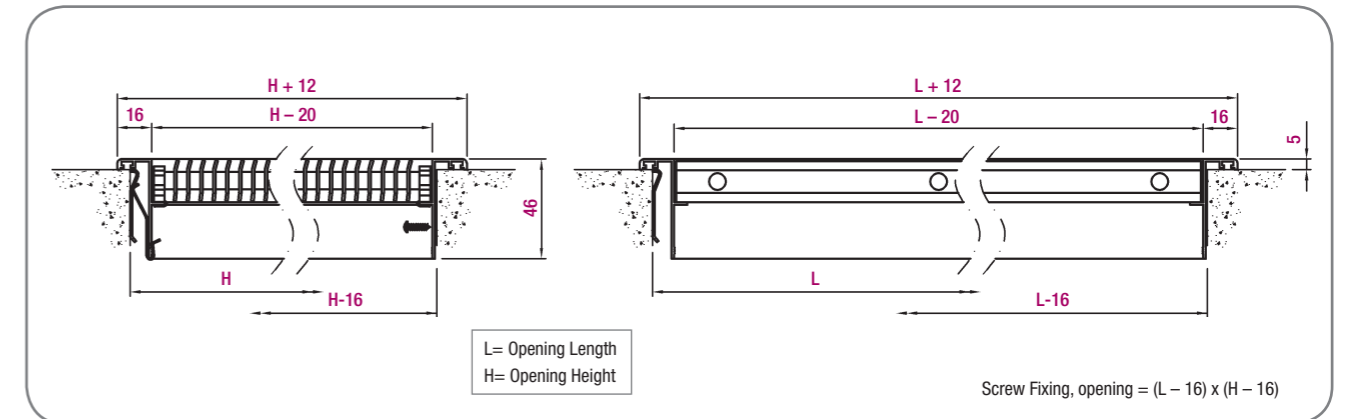

Selection table

Dimension	Q (m³/h)	L _{wa} [dB(A)]	ΔP _t (Pa)	X (m)	V _k (m/s)
325 x 125	300	24	9	3.7	3.6
	400	32	15	4.9	4.8
	530	40	27	6.5	6.4
425 x 125	360	24	7	3.9	3.3
	490	32	13	5.3	4.5
	650	40	24	7.0	6
525 x 125	430	24	7	4.2	3.2
	600	32	13	5.8	4.5
	750	40	21	7.2	5.6
625 x 125	490	24	6	4.3	3.1
	710	32	13	6.3	4.4
	850	40	19	7.5	5.3
425 x 225	640	24	6	4.9	3.3
	850	32	10	6.5	4.3
	1100	40	17	8.4	5.6
525 x 225	750	24	5	5.2	3.1
	1000	32	9	6.9	4.1
	1300	40	15	8.9	5.4
625 x 225	850	24	5	5.4	2.9
	1150	32	8	7.3	4.0
	1500	40	14	9.5	5.2
825 x 225	1150	24	5	6.3	3.0
	1500	32	8	8.2	3.9
	2000	40	15	11.0	5.3
625 x 325	1200	24	4	6.3	2.9
	1600	32	8	8.4	3.8
	2150	40	14	11.3	5.2
825 x 325	1500	24	4	6.9	2.7
	2000	32	7	9.1	3.6
	2650	40	12	12.1	4.8

The Selection Table shows a summary of dimensions. Other sizes available. Consult the Sales Department.



LEGEND

Q (m³/h): Air flow.
 L_{wa} [dB(A)]: Sound power level.
 ΔP_t (Pa): Total pressure loss.
 X (m): Throw for a maximum velocity of 0.25 m/s at the occupied zone
 ΔT = 0 °C, installed at 3 m of height, with ceiling effect.
 V_k (m/s): Effective velocity.

31-1-F



Catalogue Series 30



Linear floor grilles



Product description

Linear floor grille, KOOLAIR, model **31-1-F**, of dimensions LxH, for supplying or returning air with fixed blades (deflection 0°).

It can incorporate volume control damper (**-O**). Finished in anodised aluminium or any RAL colour upon request.

Mounting

Side or Top entry plenum box (**-PFL/PFS**) in galvanised steel sheet.

Other models

31-15-F. Linear floor grille (deflection 15°).

31-1/15-F-G. Linear floor grille (deflection 0° or 15°), with secondary blades in vertical position.

31-1/15-SB. Linear floor grille (deflection 0° or 15°), without frame.

31-1/15-NM. Linear floor grille (deflection 0° or 15°), with flat frame 28 x 1,5.

Note: Possible to form continuous lines (Maximum length per section 2000 mm).

General dimensions

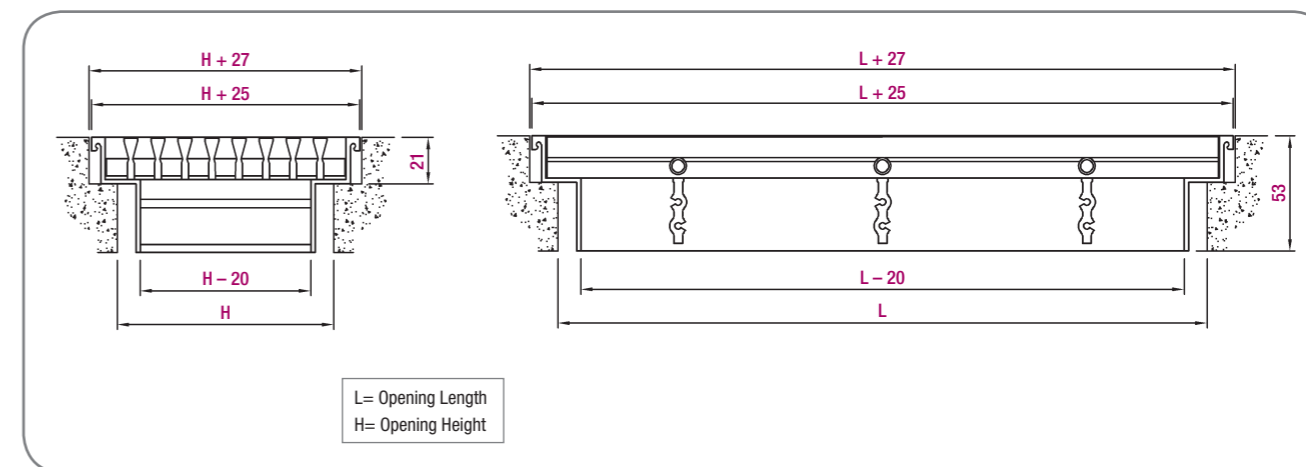

Selection table

(Flow rate per linear metre of grille)

Dimension	Q (m³/h)	L _{WA} [dB(A)]	ΔP _t (Pa)	Y (m)	V _k (m/s)
1000 x 50	290	24	7	3.5	3.4
	400	32	12	4.8	4.6
	540	40	23	6.5	6.3
1000 x 75	420	24	6	4.0	3.1
	570	32	11	5.5	4.3
	780	40	20	7.5	5.9
1000 x 100	540	24	5	4.4	3
	730	32	10	6.1	4.1
	1000	40	18	8.3	5.6
1000 x 125	650	24	5	4.8	2.9
	890	32	9	6.5	3.9
	1210	40	17	9.0	5.4
1000 x 150	790	24	4	5.2	2.8
	1080	32	8	7.1	3.8
	1480	40	15	9.7	5.1
1000 x 200	1040	24	4	5.8	2.6
	1420	32	7	7.9	3.6
	1940	40	14	10.8	4.9
1000 x 250	1260	24	4	6.2	2.5
	1720	32	7	8.5	3.4
	2360	40	13	11.7	4.8
1000 x 300	1500	24	3	6.7	2.4
	2050	32	6	9.1	3.3
	2800	40	12	12.5	4.5



LEGEND

Q (m³/h): Air flow.
L_{WA} [dB(A)]: Sound power level.
ΔP_t (Pa): Total pressure loss.
Y (m): Throw for a maximum velocity of 0.25 m/s at the occupied zone
ΔT = -10°C (cold).
V_k (m/s): Effective velocity.

The Selection Table shows a summary of dimensions. Other sizes available. Consult the Sales Department.

31-1-FS



Catalogue Series 30

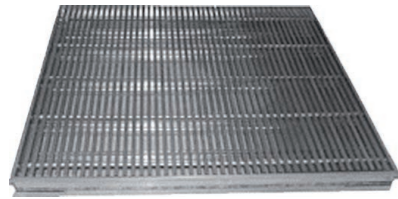

Grilles for raised access floor

Product description

The KOOLAIR **31-1-FS** linear grilles for raised access floors of LxH dimensions are especially designed for floor air supply or return. Fixed horizontal vanes of sturdy profile (0° deflection). Natural unanodized aluminum finish or RAL colour upon request. Can include volume control dampers (-O).

The units have been tested and meet EN13264:2001 requirements for heavy and extra-heavy structural classes.

The supported load is 85 kg/cm², and the evenly distributed load is 2500 kg/m².

Other models

31-15-FS. Linear grille for raised access floor with fixed horizontal vanes (15° deflection) of dimensions 599x599 or 599x299.

31-1/15-FS-G. Linear grille for raised access floor (deflection 0° or 15°) with secondary blades in vertical position.

General dimensions

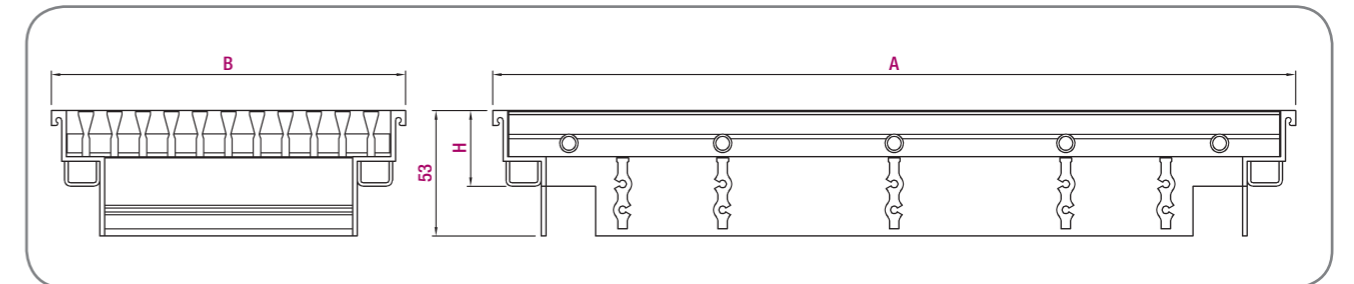

H_{min} = 21 mm

Selection table

Dimension	Q (m ³ /h)	L _{wa} [dB(A)]	ΔP _t (Pa)	Y (m)	V _k (m/s)
600 x 300	810	20	3	2.8	2.3
	1000	26	5	3.5	2.8
	1300	32	8	4.6	3.6
600 x 600	1450	20	2	3.6	2.1
	1800	26	4	4.5	2.6
	2250	32	6	5.6	3.2

LEGEND

Q (m³/h): Air flow.
 L_{wa} [dB(A)]: Sound power level.
 ΔP_t (Pa): Total pressure loss.
 Y (m): Throw for a maximum velocity of 0.25 m/s at the occupied zone
 ΔT=-10°C (cold).
 V_k (m/s): Effective velocity.



31-1-BANKSIDE



Linear supply or return grille



Product description

KOOLAIR linear supply or return grille with no external frame, model **31-1-BANKSIDE** with fixed horizontal blades (0° deflection), dimensions LxH. Option to include a regulating damper (-O). Anodised aluminium finish or painted in RAL colour of choice.

Note: Possibility of forming continuous lines (Maximum length per section 2000 mm).

Mounting

L. Mounting bracket.

PFL. Fixed plenum with lateral spigot. (-A. Interior insulated).

PFS. Fixed plenum with top spigot. (-A. Interior insulated).

Other models

31-15-BANKSIDE. Linear grille with fixed blades (deflection 15°).

31-1/15-BANKSIDE-G. Linear grille with fixed blades (deflection 0° or 15°), with 2nd deflection of vertical blades.

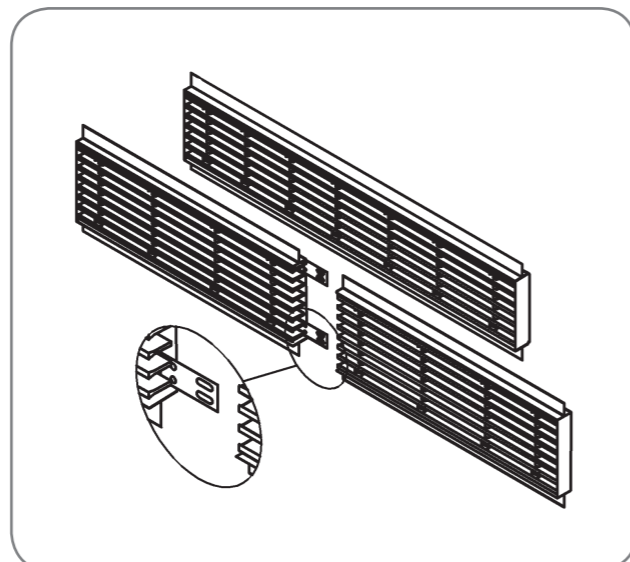

General dimensions

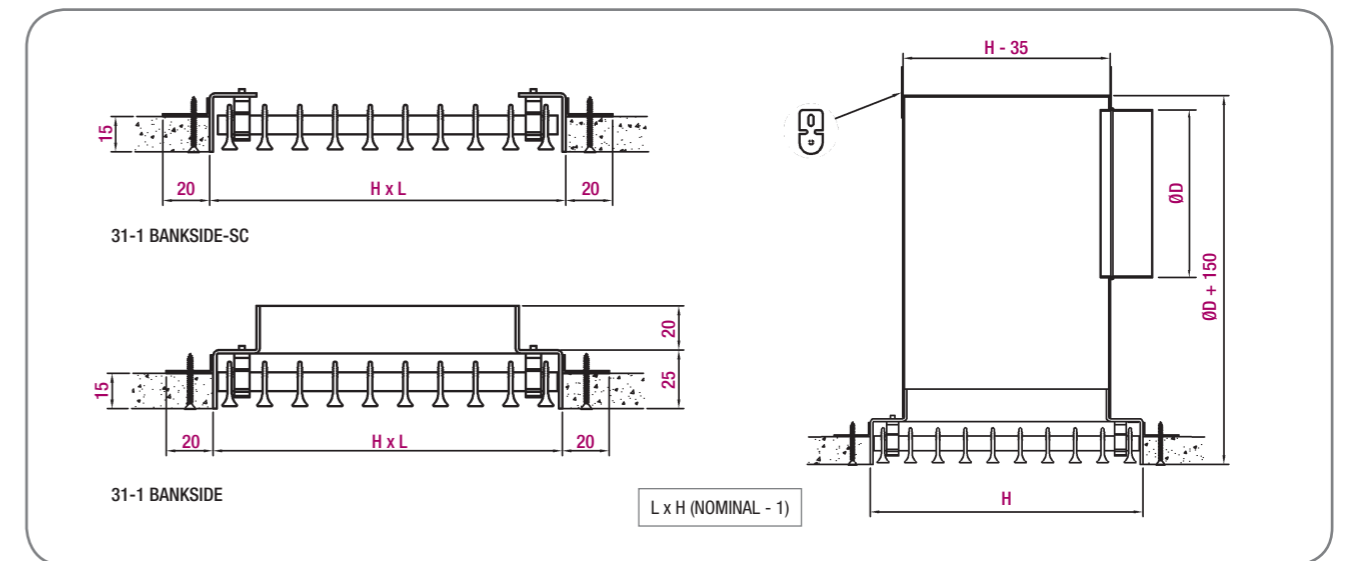

Selection table

(Flow rate per linear metre of grille)

Dimension	Q (m³/h)	L _{WA} [dB(A)]	ΔP _t (Pa)	X (m)	V _k (m/s)
1000 x 75	230	24	7	3,2	3,5
	310	32	13	4,3	4,8
	430	40	25	5,9	6,6
1000 x 100	310	24	6	3,5	3,3
	430	32	12	4,9	4,6
	590	40	23	6,8	6,3
1000 x 125	430	24	5	4,0	3,0
	600	32	10	5,6	4,3
	820	40	20	7,7	5,8
1000 x 150	560	24	5	4,5	3,0
	760	32	9	6,1	4,0
	1040	40	18	8,4	5,5
1000 x 200	780	24	4	5,2	2,8
	1070	32	8	7,1	3,8
	1460	40	16	9,6	5,2
1000 x 250	990	24	4	5,7	2,6
	1350	32	7	7,7	3,6
	1850	40	14	10,6	4,9
1000 x 300	1200	24	4	6,1	2,6
	1630	32	7	8,3	3,5
	2230	40	13	11,4	4,7

The Selection Table shows a summary of dimensions. Other sizes available. Consult the Sales Department.



LEGEND

Q (m³/h): Air flow.
 L_{WA} [dB(A)]: Sound power level.
 ΔP_t (Pa): Total pressure loss.
 X (m): Throw for a maximum velocity of 0.25 m/s at the occupied zone
 ΔT = -10 °C (cold), installed at 2.7 m of height, with ceiling effect.
 V_k (m/s): Effective velocity..

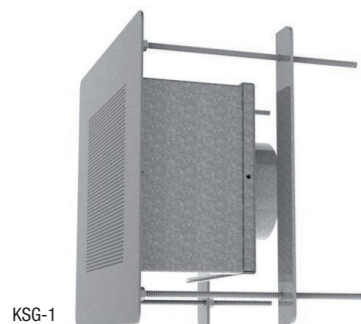

KSG-1

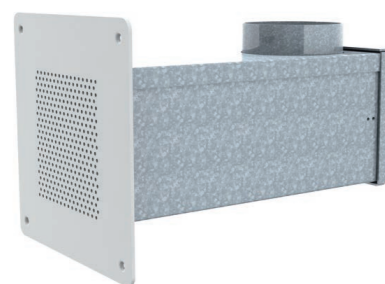

KSG-3



Safety grilles

Product description

The KOOLAIR range of safety grilles, KOOLAIR **KSG** model, of LxH dimensions is designed to cover the needs and requirements of penitentiary facilities and areas that require especially sturdy grilles. Can be used for both air supply and return. Grade 304 stainless steel grilles, polished finish. Can include volume control damper **(-O)** or intumescent damper **(-FD)**.

Mounting

Top connection plenum **(-PFS)** in galvanized steel sheet.
Lateral connection plenum **(-PFL)** in galvanized steel sheet.

Other models

KSG-1. High safety (MJ: prison cells, HO: police custody cells).
KSG-3. Medium Safety.

General dimensions

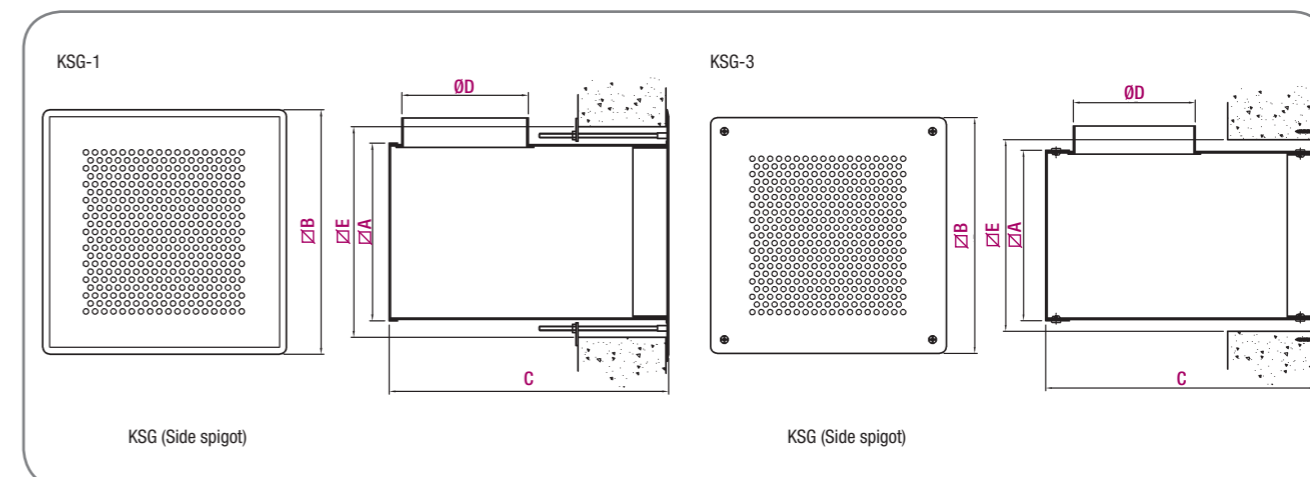

Model	A	B	C (SIDE SPIGOT)	C (TOP SPIGOT)	ØD	E
125	132	205	317	252	98	165
150	157	230	317		98	190
200	207	280	367		148	240
250	257	330	417		198	290
300	307	380	467		248	340
350	357	430	517		298	390
400	487	480	567		348	440

Unit mm (KSG-1 model dimensions)

Selection table (KSG-1)

Dimension	Q (m³/h)	L _{WA} [dB(A)]	ΔP _t (Pa)	V _f (m/s)
125 x 125	115	24	34	2.0
	150	32	58	2.7
	195	40	97	3.5
150 x 150	155	24	30	1.9
	200	32	51	2.5
	265	40	89	3.3
200 x 200	250	24	26	1.7
	330	32	46	2.3
	430	40	78	3.0
250 x 250	360	24	24	1.6
	475	32	42	2.1
	625	40	73	2.8
300 x 300	490	24	21	1.5
	640	32	37	2
	825	40	61	2.5
350 x 350	625	24	19	1.4
	835	32	34	1.9
	1.080	40	56	2.4
400 x 400	780	24	17	1.4
	1.040	32	31	1.8
	1.360	40	52	2.4



LEGEND

Q (m³/h): Air flow.
L_{WA} [dB(A)]: Sound power level.
ΔP_t (Pa): Static pressure loss.
V_f (m/s): Face velocity.



Circular diffusers

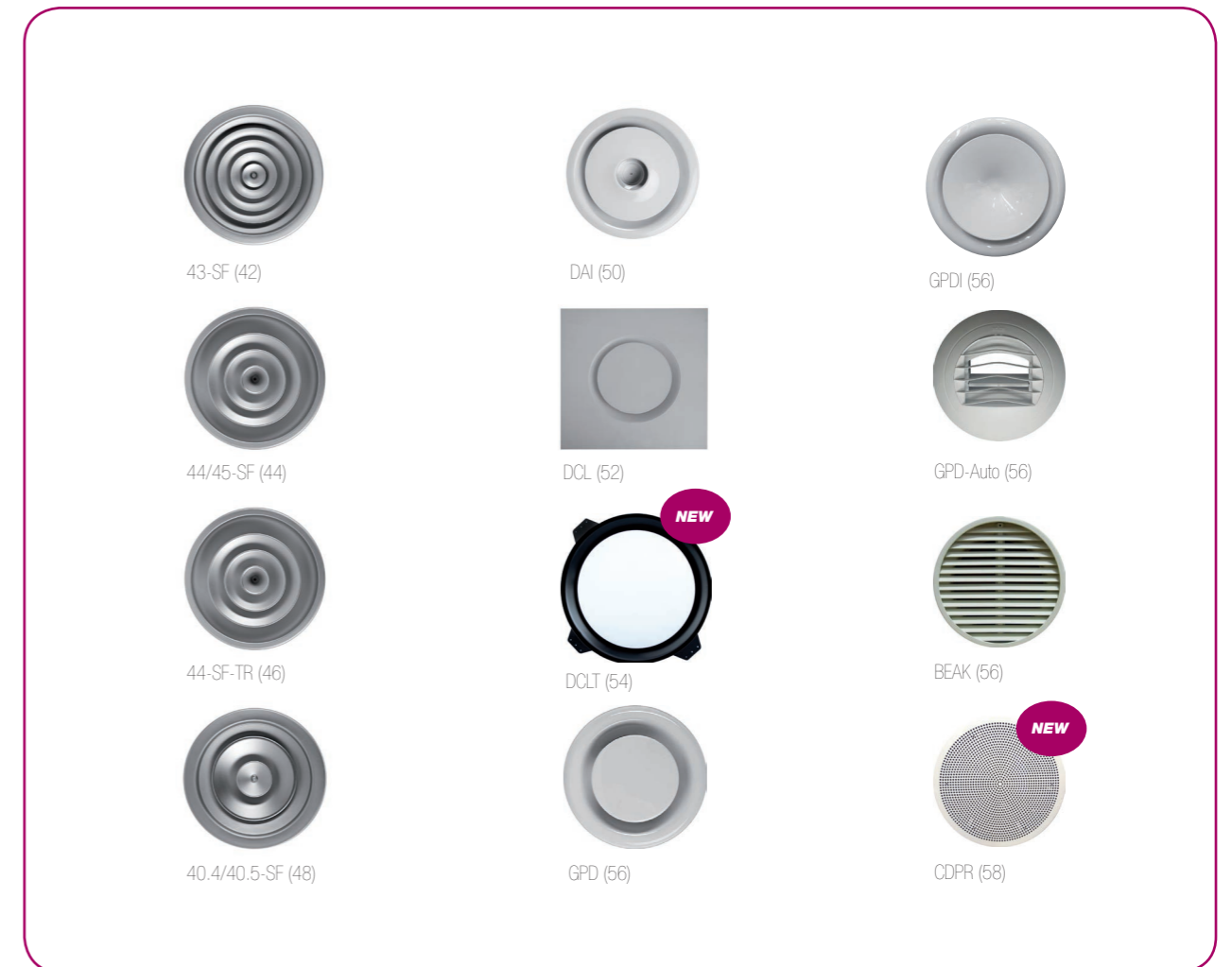

67 Lombard Street

(London – United Kingdom)

Diffusers KCD-Q with plenum
and Linear Diffuser LK-70 with plenum.

43-SF



Catalogue Series 40.1



Circular diffuser with multiple fixed cones

Product description

Circular diffuser, with multiple cones, KOOLAIR, model **43-SF** size _ mm (neck's connection diameter).

It can incorporate volume control damper (**-49MM**) and mounting accessories upon request.

Finished in anodised aluminium or any RAL colour upon request.

Recommended height installation between 2.5 and 3 m.

Mounting

PM. With mounting bridge for sheet ducts.

PMC. With mounting bridge for circular sheet ducts.

49CMM. Mounting neck with flap damper for diffuser **43-SF**.

PCDS. Top connection circular plenum in galvanized steel sheet. (**-A.** internally insulated)

PCDL. Lateral connection circular plenum in galvanized steel sheet. (**-A.** internally insulated)

Other models

43-SF-Q. Circular diffuser with fixed cones integrated in a plate of 595x595, to be installed in a modular false ceiling.

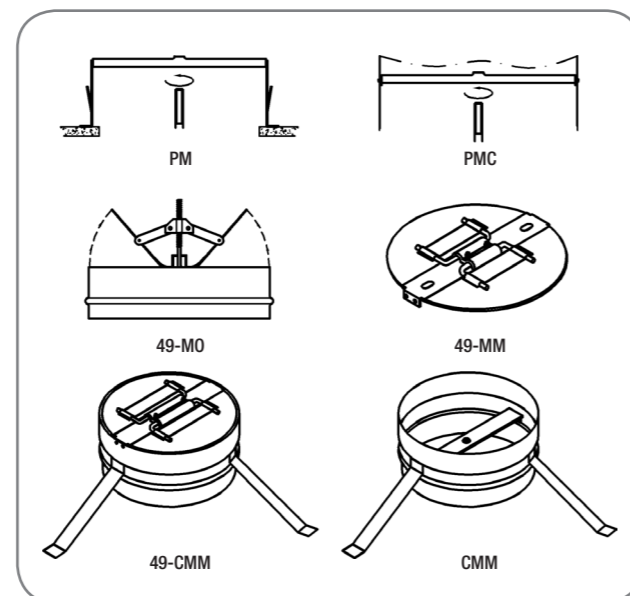

General dimensions

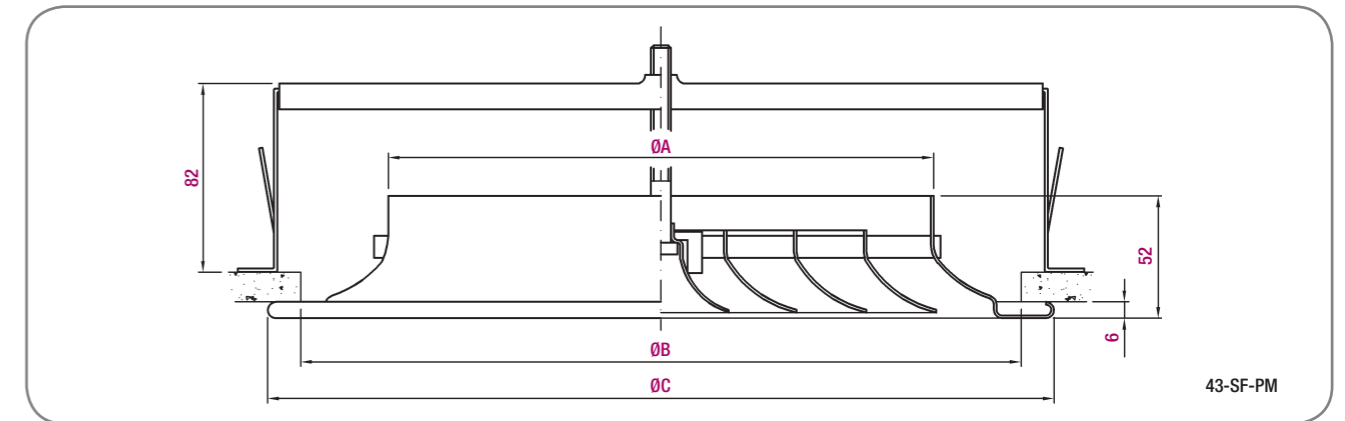

Diffuser	Ø A	Ø B	Ø C
160	159	213	247
200	199	264	287
250	249	315	337
315	314	366	402
355	354	417	442
400	399	468	487

Unit mm

Selection table

Dimension	Ø nominal	Q (m³/h)	L _{wa} [dB(A)]	ΔP _t (Pa)	X (m)	V _k (m/s)
6	160	200	24	14	1.8	5.9
		250	32	22	2.3	7.5
		310	40	34	2.9	9.4
8	200	260	24	11	2.0	5.3
		330	32	17	2.5	6.6
		410	40	27	3.1	8.3
10	250	350	24	8	2.1	4.7
		430	32	13	2.7	5.9
		550	40	21	3.4	7.4
12	315	460	24	7	2.3	4.1
		580	32	10	2.9	5.2
		730	40	17	3.7	6.5
14	355	540	24	6	2.4	3.9
		670	32	9	3.0	4.9
		850	40	15	3.8	6.1
16	400	670	24	5	2.5	3.6
		780	32	8	3.2	4.6
		990	40	13	4.0	5.7



LEGEND

Q (m³/h): Air flow.
 L_{wa} [dB(A)]: Sound power level.
 ΔP_t (Pa): Total pressure loss.
 X (m): Throw for a maximum velocity of 0.25 m/s at the occupied zone
 ΔT = -10 °C (cold), installed at a height of 3 m, with ceiling effect.
 V_k (m/s): Effective velocity.

44/45-SF



Catalogue Series 40.1



Circular diffuser with adjustable cones

Product description

Circular diffuser with core adjustable by rotation KOOLAIR, model **44-SF**, size _ mm (neck's connection diameter). It can incorporate volume control damper (**-49ML / -49-MO**) and mounting accessories upon request. Finished in anodised aluminium or any RAL colour upon request. Recommended installation height between 2.5 and 5 m.

Mounting

- PM.** With mounting bridge for sheet ducts.
- PMC.** With mounting bridge for circular sheet ducts.
- 49CML.** Mounting neck with flap damper for diffuser **44-SF**.
- 49CMK.** Mounting neck with flap damper for diffuser **45-SF**.
- PCFS.** Top connection circular plenum in galvanized steel sheet. (**-A.** internally insulated).
- PCFL.** Lateral connection circular plenum in galvanized steel sheet. (**-A.** internally insulated).

Other models

- 45-SF.** Circular diffuser with removable core, adjustable in two fixed positions.
- 44-SF-Q.** Circular diffuser with adjustable core by rotation integrated in a plate of 595x595, to be installed in a modular false ceiling (**till Ø315**).
- 45-SF-Q.** Circular diffuser with removable core integrated in a plate of 595x595, to be installed in a modular false ceiling (**till Ø315**).

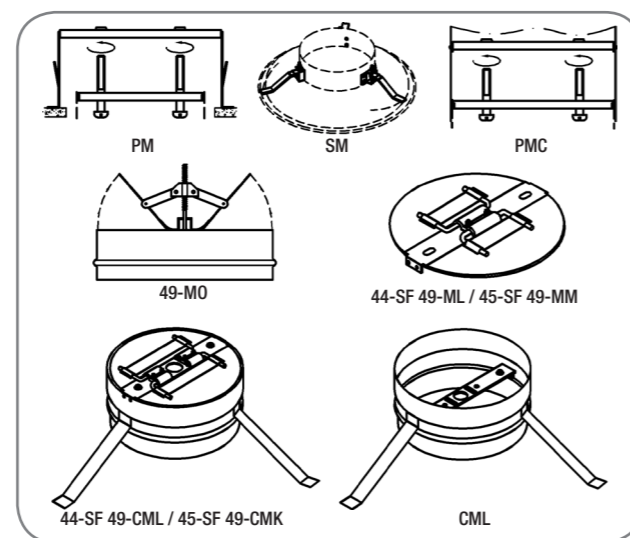

General dimensions

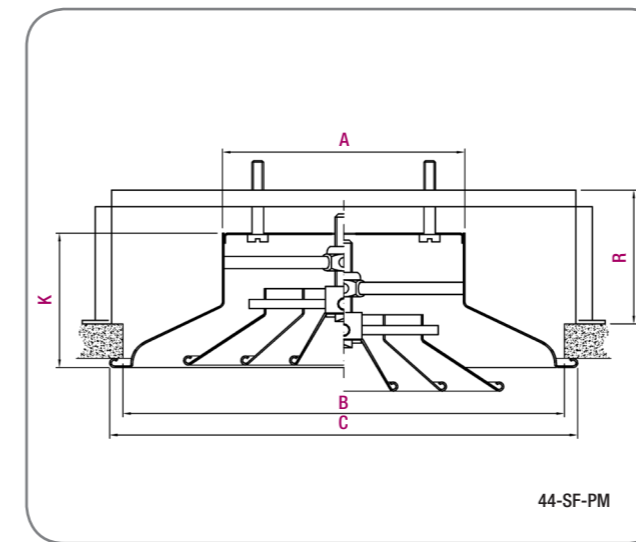

Diffuser	Ø A	Ø B	Ø C	R	K
100	99	220	240	120	82
160	159	286	316	120	90
200	199	385	415	133	121
250	249	468	498	160	123
315	314	566	606	176	142
355	354	664	714	200	167
400	399	754	814	200	168
450	449	850	920	215	186
500	499	985	1055	230	208
630	629	1108	1188	245	224

Unit mm

Selection table

Dimension	Ø nominal	Q (m³/h)	L _{wa} [dB(A)]	ΔP _t (Pa)	X (m)	V _k (m/s)
4	100	90	24	14	0.8	4.9
		110	32	24	1.0	6.3
		150	40	38	1.3	8.0
6	160	220	24	15	1.5	3.4
		280	32	25	1.8	4.3
		350	40	39	2.3	5.4
8	200	330	24	8	2.0	2.8
		440	32	14	2.6	3.7
		570	40	24	3.4	4.8
10	250	510	24	11	1.8	3.4
		660	32	19	2.4	4.4
		870	40	32	3.1	5.7
12	315	820	24	11	2.3	3.7
		1050	32	19	3.0	4.8
		1350	40	31	3.9	6.1
14	355	930	24	10	2.5	3.3
		1230	32	17	3.4	4.4
		1630	40	29	4.4	5.8
16	400	1120	24	7	2.3	3.5
		1430	32	12	3.0	4.4
		1830	40	19	3.8	5.7
18	450	1260	24	7	2.5	3.4
		1610	32	11	3.2	4.3
		2060	40	19	4.0	5.6
21	500	1530	24	7	2.7	3.3
		1960	32	11	3.4	4.2
		2500	40	18	4.4	5.4
24	630	2340	24	6	3.2	3.1
		2990	32	10	4.1	4.0
		3820	40	16	5.3	5.1

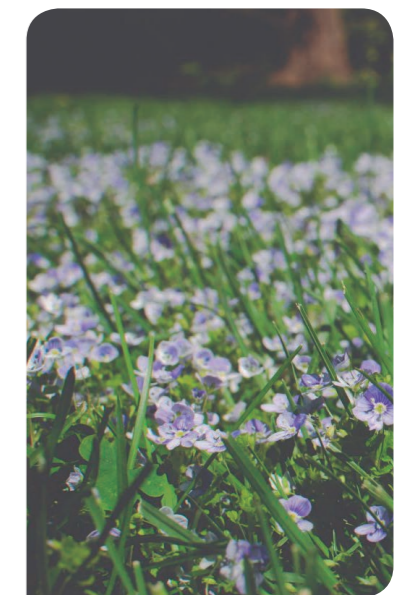

LEGEND

- Q (m³/h): Air flow.
- L_{wa} [dB(A)]: Sound power level.
- ΔP_t (Pa): Total pressure loss.
- X (m): Throw for a maximum velocity of 0.25 m/s at the occupied zone
- ΔT = -10 °C (cold), installed at a height of 3 m, with ceiling effect.
- V_k (m/s): Effective velocity.

44-SF-TR



Catalogue Diffuser 44-SF-TR



Thermo-adjustable circular diffuser

Product description

Thermo-adjustable circular diffuser, height of central core regulated by a thermal element KOOLAIR, model **44-SF-TR**, size _ (neck's connection diameter).

Recommended installation height between 3.5 and 7m.

It can incorporate volume control damper (**-49MM**) and mounting accessories upon request.

Finished in anodised aluminium or any RAL colour upon request.

Other models

44-SF-TR-Q. Circular diffuser thermo-adjustable, integrated in a plate of 595x595, to be installed in a modular false ceiling (**up to size Ø315**).

Mounting

PM. Mounting bridge for sheet ducts.

PMC. Mounting bridge for circular sheet ducts.

49CML. Mounting neck with flap damper.

PCFS. Top connection circular plenum in galvanized steel sheet. (**-A**. internally insulated)

PCFL. Lateral connection circular plenum in galvanized steel sheet. (**-A**. internally insulated)

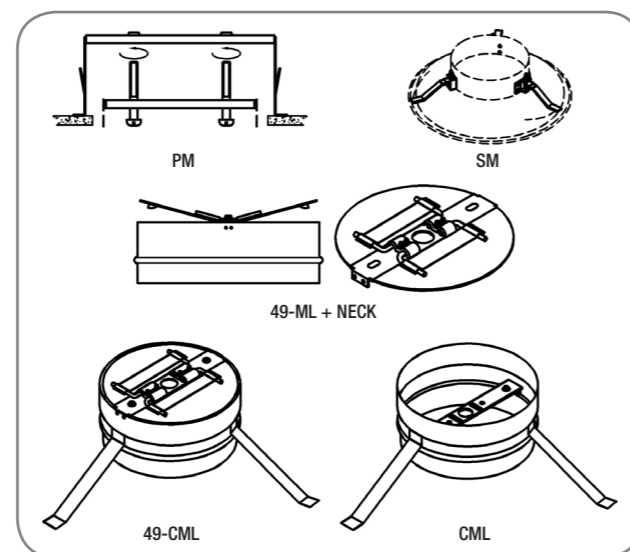

General dimensions

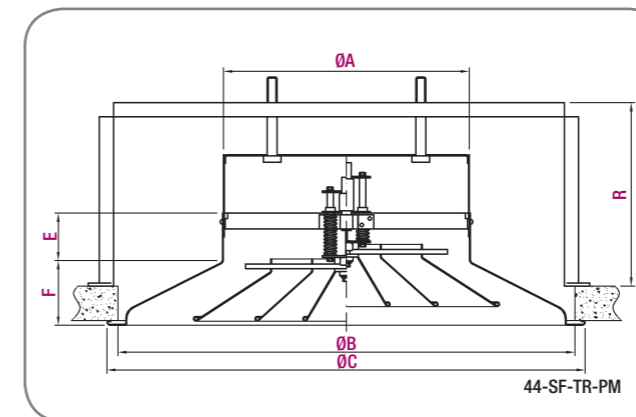

Diffuser	Ø A	Ø B	Ø C	E	F	R
160	159	286	316	45	45	166
200	199	385	415	55	66,5	216
250	249	468	498	55	68	222
315	314	566	606	60	82	238
355	354	664	714	60	106	272

Unit mm

Selection table (Horizontal discharge)

Dimension	Q (m³/h)	L _{WA} [dB(A)]	ΔP _t (Pa)	X (m)	V _k (m/s)
160	280	32	25	1.8	4.3
	350	40	39	2.3	5.4
	450	48	63	2.9	6.9
200	440	32	14	2.6	3.7
	570	40	24	3.4	4.8
	740	48	48	4.2	4.4
250	660	32	19	2.4	4.4
	870	40	32	3.1	5.7
	1130	48	55	4.1	7.5
315	1060	32	19	3.0	4.8
	1360	40	31	3.9	6.1
	1740	48	50	4.9	7.8
355	1230	32	17	3.4	4.4
	1630	40	29	4.4	5.8
	2150	48	51	5.9	7.7

Selection table (Vertical discharge)

Dimension	Q (m³/h)	L _{WA} [dB(A)]	ΔP _t (Pa)	Y _{max} (m)	V _k (m/s)
160	240	32	22	3.24	5.2
	320	40	39	4.32	7.0
	420	48	66	5.66	9.1
200	301	32	15	2.33	3.4
	420	40	28	3.19	4.7
	580	48	52	4.41	6.5
250	540	32	18	3.14	4.3
	720	40	31	4.21	5.7
	670	48	56	5.64	7.6
315	870	32	18	3.64	4.8
	1140	40	30	4.78	6.3
	1500	48	52	6.28	8.3
355	900	32	16	3.26	4.1
	1300	40	27	4.28	5.4
	1700	48	47	5.60	7.0



LEGEND

Q (m³/h): Air flow.

L_{WA} [dB(A)]: Sound power level.

ΔP_t (Pa): Total pressure loss.

X (m): Throw for a maximum velocity of 0.25 m/s at the occupied zone
 ΔT = -10 °C (cold), installed at a height of 3 m, with ceiling effect.

V_k (m/s): Effective velocity.

Y_{max} (m): Maximum vertical penetration at ΔT = +10 °C (heating).

40.4/40.5-SF



Catalogue Series 40.1



Circular diffuser with adjustable cones

Product description

Circular cones diffuser (2 rings) adjustable by rotation, KOOLAIR, model **40.4-SF**, size _ mm (neck's connection diameter). It can incorporate volume control damper (-49ML / -49MO) and mounting accessories upon request. Finished in anodised aluminium or any RAL colour upon request. Recommended installation height between 2.5 and 5 m.

Other models

40.5-SF. Circular diffuser with removable core, adjustable in two fixed positions (up to size Ø630).
40.4-SF-Q. Circular diffuser with adjustable core by rotation integrated in a plate of 595x595, to be installed in a modular false ceiling (up to size Ø355).
40.5-SF-Q. Circular diffuser with removable core integrated in a plate of 595x595, to be installed in a modular false ceiling (up to size Ø355).

Mounting

PM. Mounting bridge for sheet ducts.
PMC. Mounting bridge for circular sheet ducts.

49CML. Mounting neck with flap damper for diff. **40.4-SF** (up to size Ø400).
49CMK. Mounting neck with flap damper for diff. **40.5-SF** (up to size Ø400).
PCFS. Top connection circular plenum in galvanized steel sheet. (-A. internally insulated)
PCFL. Lateral connection circular plenum in galvanized steel sheet. (-A. internally insulated)

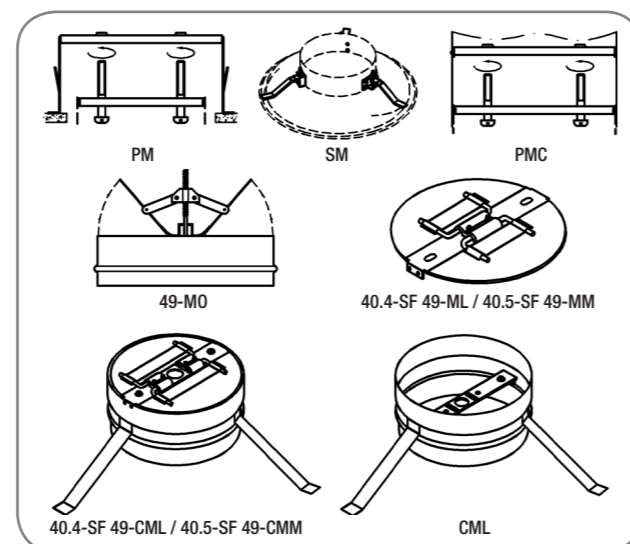

General dimensions

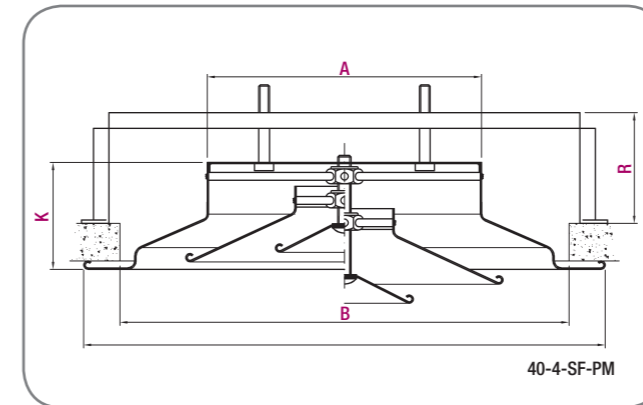

Diffuser	Ø A	Ø B	Ø C	R	K
100	99	187	225	116	74,5
160	159	245	291	116	86
200	199	324	378	116	94,5
250	249	390	454	116	103,5
315	314	468	537	141	120,5
355	354	545	624	158	133,5
400	399	614	704	198	171,5
450	449	689	788	-	187,5
500	499	764	872	-	200
630	629	955	1063	-	222
710	709	1070	1180	-	217
800	799	1200	1323	-	248
900	899	1350	1470	-	281

Unit mm

Selection table

Dimension	Ø nominal	Q (m³/h)	L _{WA} [dB(A)]	ΔP _t (Pa)	X (m)	V _k (m/s)
4	100	90	24	13	1.3	3.5
		120	32	24	1.7	4.8
		170	40	44	2.4	6.6
6	160	150	24	7	1.7	4.0
		200	32	13	2.3	5.4
		270	40	24	3.2	7.3
8	200	350	24	14	3.0	5.2
		460	32	25	4.0	6.9
		620	40	44	5.4	9.2
10	250	560	24	15	3.9	5.4
		740	32	25	5.1	7.1
		970	40	44	6.8	9.3
12	315	810	24	12	4.5	4.9
		1050	32	20	5.8	6.4
		1370	40	35	7.6	8.3
14	355	1070	24	12	5.1	4.8
		1380	32	21	6.6	6.2
		1780	40	34	8.5	8.0
16	400	1300	24	12	5.7	4.9
		1660	32	20	7.2	6.3
		2120	40	33	9.2	8.0
18	450	1540	24	12	6.2	5.0
		1940	32	19	7.9	6.4
		2460	40	31	10.0	8.1
21	500	1780	24	12	6.8	5.2
		2230	32	19	8.6	6.5
		2800	40	30	10.7	8.2
24	630	2570	24	12	8.4	5.5
		3150	32	18	10.4	6.8
		3890	40	28	12.8	8.3

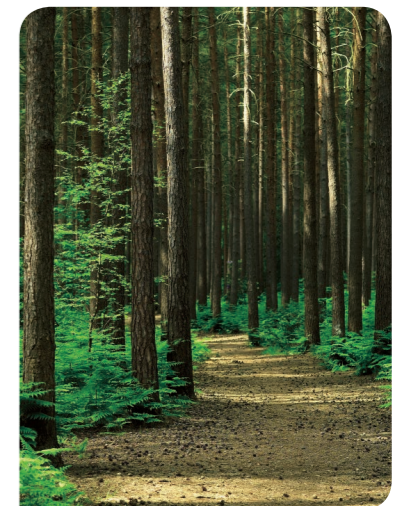

LEGEND

Q (m³/h): Air flow.
L_{WA} [dB(A)]: Sound power level.
ΔP_t (Pa): Total pressure loss.
X (m): Throw for a maximum velocity of 0.25 m/s at the occupied zone
ΔT = -10 °C (cold), installed at a height of 3 m, with ceiling effect.
V_k (m/s): Effective velocity.

DAI



Catalogue DAI



High-induction circular diffuser

Product description

High-induction circular diffuser, for mixing primary air and inducted ambient air. KOOLAIR, model **DAI**, size _ mm (neck's connection diameter). Made in aluminium. Finished in any RAL colour upon request. Recommended installation height between 2.5 and 3 m.

Other models

DAI-Q. Circular high induction diffuser integrated in a plate of 595x595, to be installed in a modular false ceiling (**up to size 315**).

Mounting

SMAI. High-induction mounting system, with volume control damper.

49SMAI. Mounting neck with volume control damper.

PCFS. Top connection circular plenum in galvanized steel sheet. (-A. internally insulated).

PCFL. Lateral connection circular plenum in galvanized steel sheet. (-A. internally insulated).

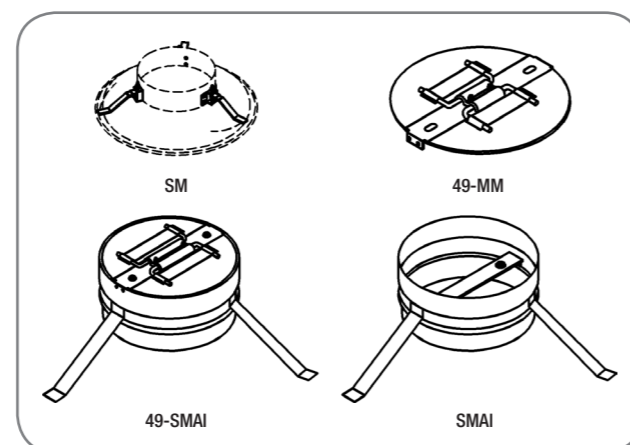

General dimensions

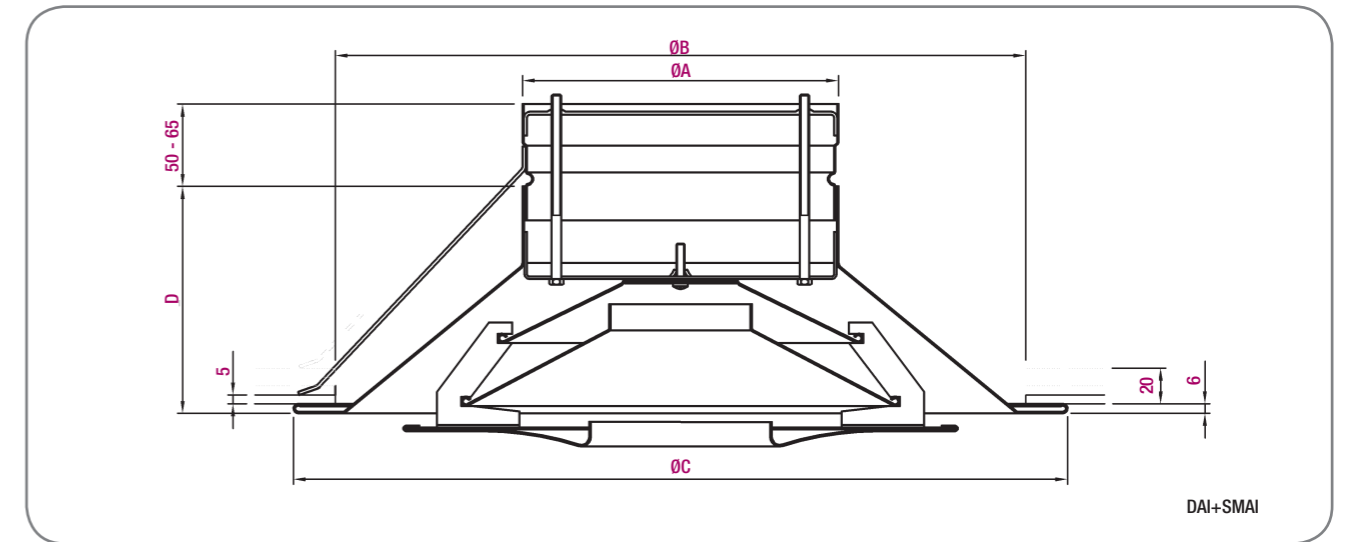

Diffuser	A	B	C	D
160	159	358	418	133
200	199	428	486	141
250	249	520	579	158
315	314	567	625	153
355	354	637	696	164

Unit mm

Selection table

Dimension	Q (m³/h)	L _{wa} [dB(A)]	ΔP _t (Pa)	X (m)
160	140	24	10	0.9
	190	32	18	1.2
	240	40	28	1.6
200	250	24	12	1.4
	330	32	21	1.8
250	420	40	34	2.3
	400	24	13	1.9
315	510	32	21	2.5
	660	40	35	3.2
	590	24	12	2.5
355	760	32	20	3.3
	970	40	22	4.0
	700	24	11	2.9
	900	32	19	3.7
	1150	40	30	4.7

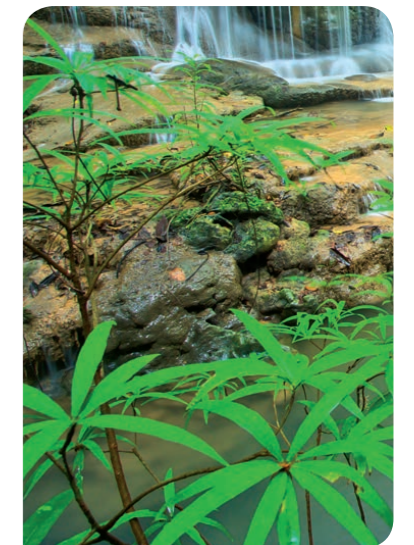

LEGEND

Q (m³/h): Air flow.
 L_{wa} [dB(A)]: Sound power level.
 ΔP_t (Pa): Total pressure loss.
 X (m): Throw for a maximum velocity of 0.25 m/s at the occupied zone
 ΔT = -10 °C (cold), installed at a height of 3 m.

DCL



Catalogue Diffuser DCL



Circular diffuser

Product description

Circular diffuser, KOOLAIR, model **DCL**, size _ mm (neck's connection diameter). It can incorporate volume control damper and mounting neck. Finished in any RAL colour upon request. Recommended installation height between 2.5 and 5 m.

Mounting

- SM.** Mounting system.
- 49CML.** Mounting neck with volume control damper.
- PCFS.** Top connection circular plenum in galvanized steel sheet. (-A. internally insulated).
- PCFL.** Lateral connection circular plenum in galvanized steel sheet. (-A. internally insulated).

Other models

- DCL-Q.** Circular diffuser integrated in a plate of 595x595, to be installed in a modular false ceiling (**till size Ø 315**).
- DCL-TR.** Thermo-adjustable circular diffuser.
- DCL-TR-Q.** Thermo-adjustable circular diffuser integrated in a plate of 595x595, to be installed in a modular false ceiling (**till size Ø 315**).

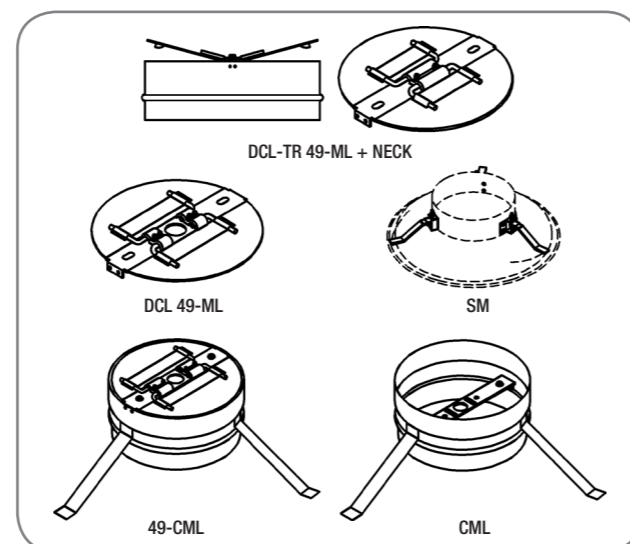

General dimensions

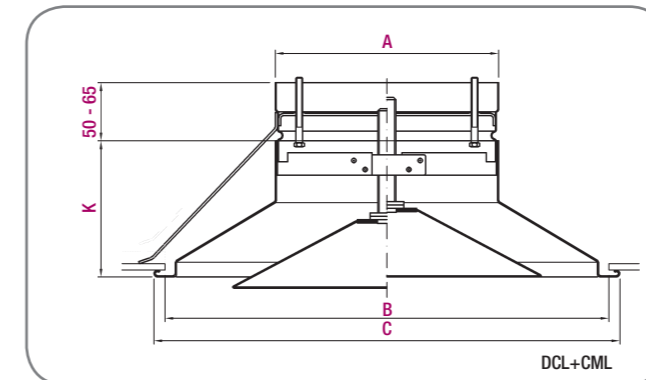

Opening	Ø A	Ø B	Ø C	K
125	124	252	272	90
160	159	286	316	90
200	199	385	415	121
250	249	468	498	123
315	314	566	606	142

Unit mm

Selection table (Horizontal discharge)

Dimension	Q (m³/h)	L _{wa} [dB(A)]	ΔP _t (Pa)	X (m)
125	135	24	11	0,5
	180	32	18	0,7
	230	40	30	0,9
160	160	24	11	0,6
	230	32	20	0,9
	300	40	36	1,2
200	300	24	15	1,0
	390	32	23	1,3
	515	40	41	1,7
250	480	24	14	1,4
	600	32	24	1,7
	800	40	42	2,3
315	720	24	15	1,8
	860	32	23	2,2
	1150	40	40	2,9

Selection table (Vertical discharge *)

Dimension	Q (m³/h)	L _{wa} [dB(A)]	ΔP _t (Pa)	Y _{max} (m)
125	140	32	24	3,3
	185	40	41	4,3
	240	48	70	5,6
160	215	32	28	3,5
	280	40	48	4,5
	365	48	82	5,9
200	265	32	17	2,4
	360	40	31	3,2
	495	48	58	4,4
250	470	32	21	3,3
	625	40	37	4,3
	840	48	67	5,8
315	760	32	21	3,8
	1000	40	37	5,0
	1300	48	62	6,5

* Apply vertical discharge outlets for ceiling heights > 3 m or with exposed installations.

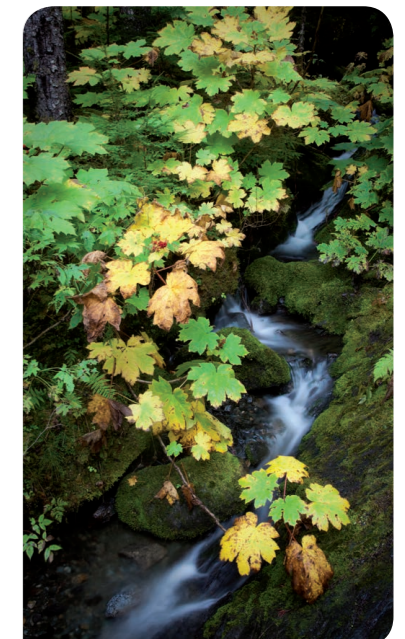

LEGEND

- Q (m³/h): Air flow.
- L_{wa} [dB(A)]: Sound power level.
- ΔP_t (Pa): Total pressure loss.
- X (m): Throw for a maximum velocity of 0.25 m/s at the occupied zone
- ΔT = -10 °C (cold), installed at a height of 3 m.
- Y_{max} (m): Maximum vertical penetration at ΔT = +10 °C (heating).

DCLT



Circular diffuser

Product description

KOOLAIR hidden circular diffuser, model **DCLT**, size _ mm (connection Ø), for installation in suspended drywall ceilings.

Characterised by the lack of profile on show. Complete with movable central core to discharge air horizontally and vertically.

Option to include a regulating damper and/or plenum with lateral/top connection.

Painted finish in RAL colour of choice.

Recommended installation height between 2.5 and 5 m.

Mounting

49ML. Regulating damper.

PCFS. Top connection circular plenum in galvanized steel sheet. (-A. internally insulated).

PCFL. Lateral connection circular plenum in galvanized steel sheet. (-A. internally insulated).

Other models

DCLT-TR. Temperature-adjustable circular diffuser

DCLT-PANEL. Circular diffuser with plasterboard central core.

DCLT-TR-PANEL. Temperature-adjustable circular diffuser with plasterboard central core.

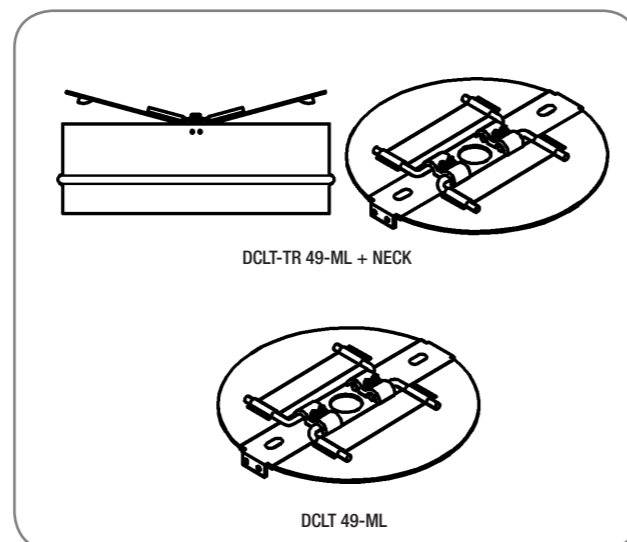

General dimensions

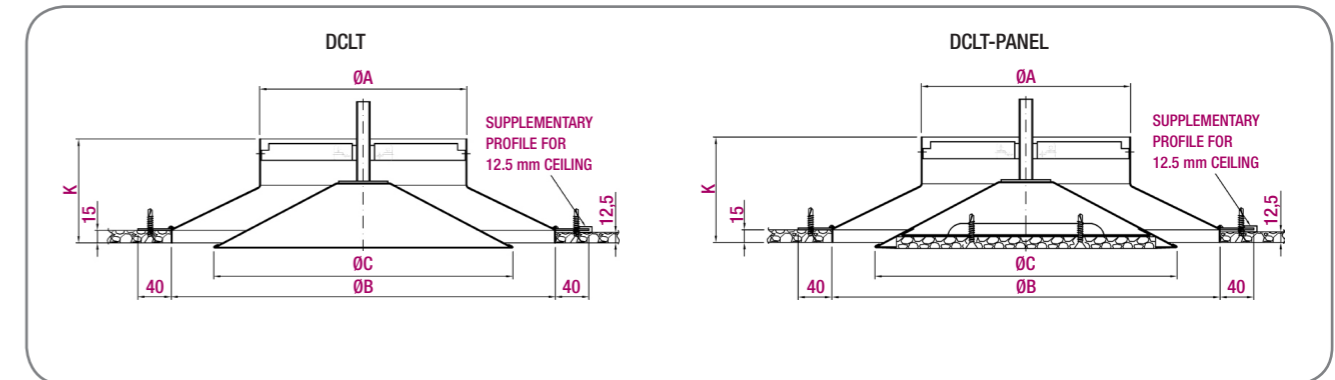

Selection table (Horizontal discharge)

Dimension	Q (m³/h)	L _{wa} [dB(A)]	ΔP _t (Pa)	X (m)
125	135	24	11	0,5
	180	32	18	0,7
	230	40	30	0,9
160	160	24	11	0,6
	230	32	20	0,9
	300	40	36	1,2
200	300	24	15	1,0
	390	32	23	1,3
	515	40	41	1,7
250	480	24	14	1,4
	600	32	24	1,7
	800	40	42	2,3
315	720	24	15	1,8
	860	32	23	2,2
	1150	40	40	2,9

Model	Ø A	Ø B	Ø C	K
125	124	245	204	100
160	159	275	218	100
200	199	375	283	125
250	249	460	356	130
315	314	560	457	150

Unit mm

Installation detail

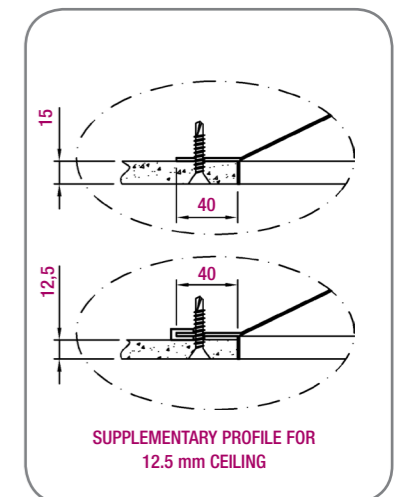

Selection table (Vertical discharge *)

Dimension	Q (m³/h)	L _{wa} [dB(A)]	ΔP _t (Pa)	Y _{max} (m)
125	140	32	24	3,3
	185	40	41	4,3
	240	48	70	5,6
160	215	32	28	3,5
	280	40	48	4,5
	365	48	82	5,9
200	265	32	17	2,4
	360	40	31	3,2
	495	48	58	4,4
250	470	32	21	3,3
	625	40	37	4,3
	840	48	67	5,8
315	760	32	21	3,8
	1000	40	37	5,0
	1300	48	62	6,5

* Apply vertical discharge for ceiling heights > 3 m or with exposed installations.

LEGEND

Q (m³/h): Air flow.
 L_{wa} [dB(A)]: Sound power level.
 ΔP_t (Pa): Total pressure loss.
 X (m): Throw for a maximum velocity of 0.25 m/s at the occupied zone
 ΔT = -10 °C (cold), installed at a height of 3 m.
 Y_{max} (m): Maximum vertical penetration at ΔT = +10 °C (heating).

GPD



Catalogue Extraction Valves



GPD



GPDI



Exhaust/supply outlets

Product description

Exhaust/supply outlets, KOOLAIR, **GPD** model - for use in confined spaces (bathrooms, lavatories, kitchens, etc).

Standard finish in RAL 9010.

Other models

GPD. Circular exhaust outlet.

GPDI. Circular supply outlet.

GPD-Auto. Circular self-adjusting plastic extract valve.

BEAK. Circular aluminium extract valve.



Mounting

With metal mounting ring (-AM).



General dimensions GPD

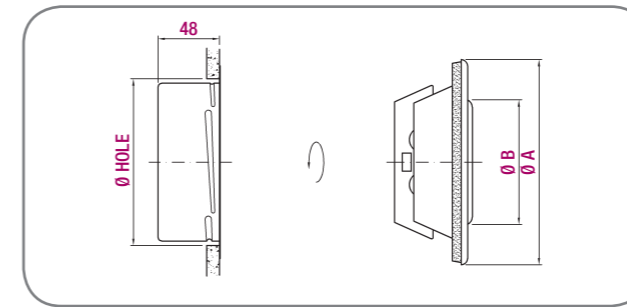

Model	Ø A	Ø B	Ø Hole
GPD-80	115	62	85
GPD-100	138	75	105
GPD-125	164	100	130
GPD-150	202	120	155
GPD-160	211	130	165
GPD-200	248	158	205

Unit mm

General dimensions GPDI

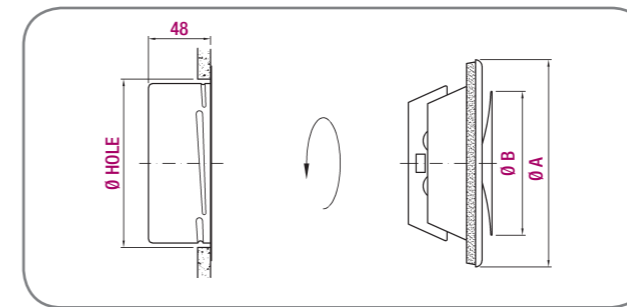

Model	Ø A	Ø B	Ø Hole
GPDI-80	115	76	85
GPDI-100	138	92	105
GPDI-125	164	111	130
GPDI-150	202	135	155
GPDI-160	211	147	165
GPDI-200	248	194	205

Unit mm

General dimensions BEAK

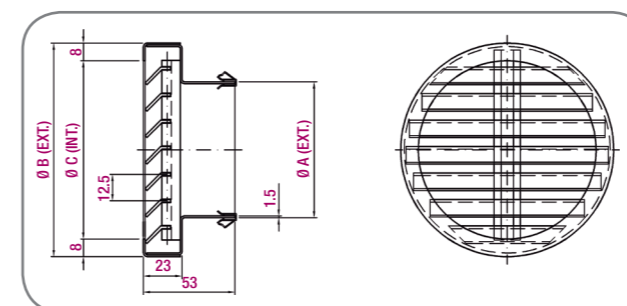

Model	Ø A	Ø B	Ø C
BEAK-80	75	120	100
BEAK-100	95	160	140
BEAK-125	120	160	140
BEAK-160	155	200	180

Unit mm

Selection table

Dimension	Q (m³/h)	L _{WA} [dB(A)]	ΔP _t (Pa)
80	45	20	18
	60	25	28
	70	30	43
100	65	20	36
	75	25	49
	90	30	68
125	110	20	27
	135	25	38
	160	30	55
150	120	20	25
	145	25	37
	160	30	50
160	125	20	26
	150	25	37
	170	30	52
200	215	20	31
	250	25	45
	290	30	58

Data for 5 mm core adjustment.

Selection table

Dimension	Q (m³/h)	L _{WA} [dB(A)]	ΔP _t (Pa)
80	40	20	18
	45	25	28
	50	30	38
100	45	20	18
	55	25	28
	65	30	38
125	80	20	21
	100	25	29
	115	30	42
150	105	20	28
	135	25	48
	160	30	75
160	110	20	27
	140	25	37
	170	30	50
200	200	20	29
	270	25	38
	320	30	55

Data for 6 mm core adjustment.

Selection table

Dimension	Q (m³/h)	L _{WA} [dB(A)]	ΔP _t (Pa)
80	50	25	19
	68	30	36
	82	35	52
100	85	25	21
	115	30	37
	141	35	55
125	97	25	15
	128	30	26
	152	35	35
160	150	25	13
	200	30	22
	233	35	29

LEGEND

Q (m³/h): Air flow.

L_{WA} [dB(A)]: Sound power level.

ΔP_t (Pa): Total pressure loss.

CDPR



Multi-directional round diffuser

Product description

KOOLAIR, **CDPR**, size _ mm (Ø connection) perforated plate round diffuser, hanged from the ceiling. The configuration of the diffuser allows the radial air jet supply to be configured in 1, 2 or 3 directions to suit the needs of the end user. Removable faceplate to allow the interior of the diffuser to be cleaned and provide access to the control damper and the air jet setting system. It can incorporate plenum connection with regulation damper. Finish in RAL colour of choice.

Others models

- CDPR-HD.** Perforated plate round diffuser with perforations arranged in a decreasing concentric circle design.
- CDPR-C.** Plate round diffuser with a smooth design (no perforations).
- CDPR-R.** Perforated plate round diffuser for air return.
- CDPR-HD-R.** Perforated plate circular diffuser for return air with perforations arranged in a decreasing concentric circle design.
- CDPR-C-R.** Plate round diffuser for return air with a smooth design (no perforations).

Mounting

- PCFS-RE.** Round plenum with top connection complete with galvanised sheet steel control damper. (-A. Interior insulated).
- PCFL-RE.** Round plenum with side connection complete with galvanised sheet steel control damper. (-A. Interior insulated).
- SFO.** Incorporates hidden fastening system.

General dimensions

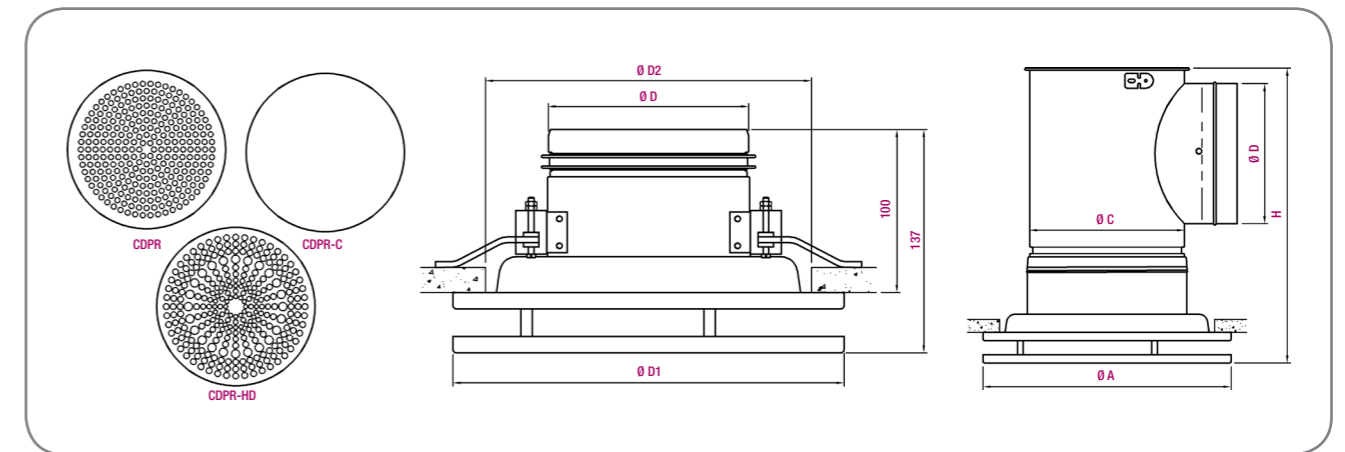

Custom plenums available to suit reduced heights above false ceilings.

Diffuser	Ø D	Ø D1	Ø D2
100	98	240	200
125	123	240	200
160	158	300	260
200	198	360	320
250	248	460	420
315	313	540	500
400	398	540	500

Unit size in mm - diffuser only

Diffuser	Ø A	Ø C	Ø D	H
100	240	103	98	290
125	240	128	123	315
160	300	163	158	350
200	360	203	198	390
250	460	253	198	440
315	540	318	248	505
400	540	403	313	590

Unit size in mm - diffuser + plenum

Selection Table

Technical data corresponding to CDPR model without plenum

Size	Q (m³/h)	L _{WA} [dB(A)]	ΔP _t (Pa)	X (m)	V _e (m/s)
100	140	24	13	1,3	2,0
	180	32	22	1,7	2,6
	235	40	37	2,2	3,4
125	160	24	13	1,4	2,1
	205	32	21	1,9	2,7
	260	40	35	2,4	3,5
160	200	24	9	1,7	2,2
	260	32	16	2,1	2,8
	335	40	26	2,8	3,6
200	260	24	7	1,9	2,2
	335	32	12	2,5	2,9
	435	40	20	3,2	3,7
250	350	24	7	2,3	2,3
	450	32	11	2,9	3,0
	585	40	18	3,8	3,9
315	550	24	6	2,9	2,5
	710	32	10	3,8	3,2
	920	40	17	4,9	4,2
400	800	24	7	3,8	2,9
	1040	32	12	4,9	3,7
	1340	40	20	6,3	4,8

LEGEND

- Q (m³/h): Air flow.
- L_{WA} [dB(A)]: Sound power level.
- ΔP_t (Pa): Pressure loss.
- X (m): Horizontal throw of air jet for a velocity of 0.25 m/s in occupied zone, temperature difference ΔT = -10° C and an installation height of 3 m.
- V_e (m/s): Effective velocity.

Swirl diffusers

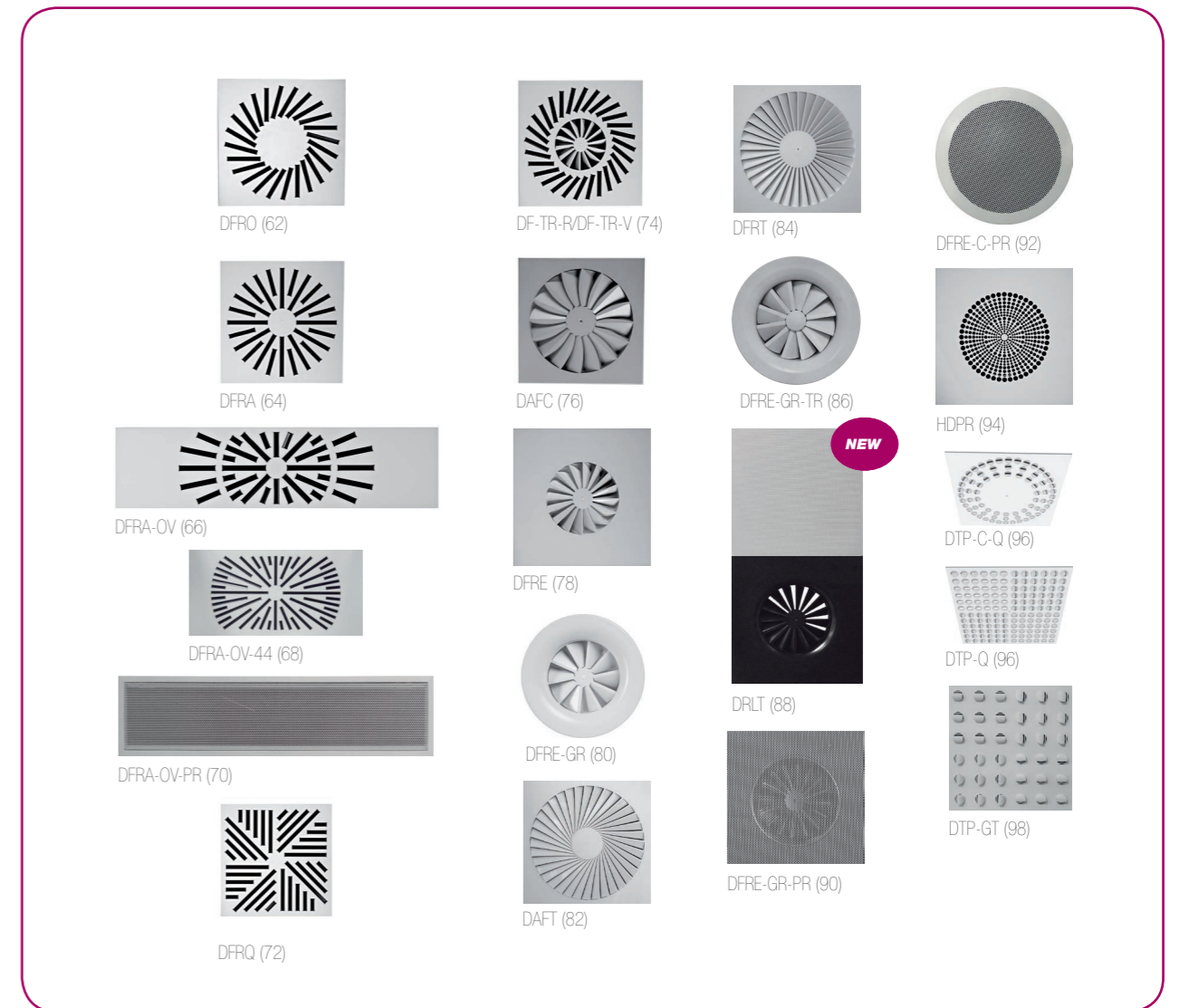

**Express Park
(Bridgwater, Somerset - United Kingdom)**

Security grilles KSG-1,
boxes for constant air volume KSV and KSVL
and boxes for variable air volume KS and KSL.

DFRO



Catalogue Series 40.2



Adjustable blade swirl diffuser

Product description

Adjustable blades swirl diffuser, KOOLAIR, model **DFRO**, size __, plate dimension of __x__. It incorporates a plenum box with side connection made in galvanised steel sheet, with spigot inlet volume control damper.

Made in steel sheet. Finished in any RAL colour upon request.

Recommended installation height between 2.5 and 3.5 m.

Other models

DFRO-__60. Circular diffuser integrated in a plate of 595x595, to be installed in a modular false ceiling (up to size 4860).

DFRO-E. Circular swirl diffuser for plaster ceiling plate.

DFRO-C. Circular swirl diffuser for circular plate.

DFRO-A. Circular swirl diffuser in plate, without blades.

Note: On request, top plenum available insulated/ uninsulated (PDS-A-RE/PDS-RE).

Mounting

PDL-RE. Plenum with side connection without insulation for square panel, with manual damper accessible from false ceiling.

PDL-A-RE. Plenum with side connection internally insulated for square panel, with manual damper accessible from false ceiling.

PDL-RL. Plenum with side connection without insulation for square panel, with manual damper accessible from room.

PDL-A-RL. Plenum with side connection internally insulated for square panel, with manual damper accessible from room.

PCDL-RL. Plenum with side connection without insulation for round panel, with manual damper accessible from room.

PCDL-A-RL. Plenum with side connection internally insulated for round panel, with manual damper accessible from room.

RPM. Damper equipped to allow motorization.

PM. Mounting bridge. To be installed without plenum in plaster ceilings, good for returning air or just decorative.

General dimensions

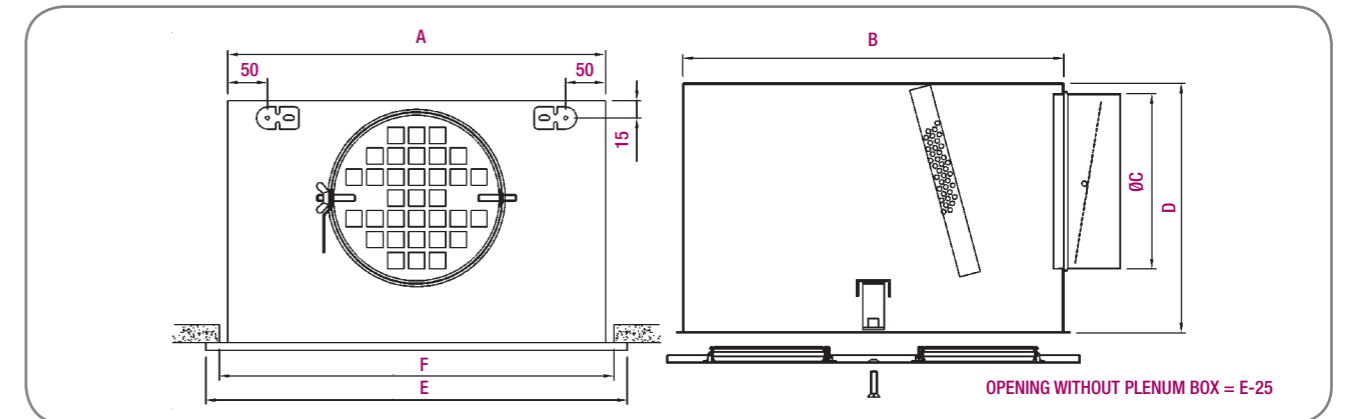

Custom plenums available to suit reduced heights above false ceilings.

Diffuser	A	B	C	D	E	F
12	288	270	159	250	294	290
16	388	370	199	300	394	390
20	488	470	199	300	494	490
24 / 32 / 4860	588	570	249	350	594	590
36	616	598	249	350	623	618
40	663	645	314 OVAL	350	670	665
48	788	770	314	410	794	790

Unit mm

Selection table

Size	Q (m³/h)	L _{wa} [dB(A)]	ΔP _t (Pa)	B (m)
12	140	24	15	1,2
	190	32	26	1,7
	240	40	43	3,0
16	210	24	9	1,5
	270	32	15	2,7
	360	40	26	3,6
20	300	24	10	2,5
	390	32	18	3,5
	510	40	30	4,3
24	400	24	9	3,2
	530	32	16	4,2
	690	40	27	5,5
32	470	24	10	3,0
	610	32	17	4,1
	790	40	29	4,8
4860	480	24	10	3,1
	620	32	17	4,2
	810	40	31	4,9
36	490	24	11	3,0
	640	32	18	4,0
	830	40	31	5,0
40	600	24	10	3,2
	790	32	18	4,3
	1030	40	30	5,0
48	730	24	10	3,7
	950	32	17	4,5
	1240	40	29	5,4



LEGEND

Q (m³/h): Air flow.
 L_{wa} [dB(A)]: Sound power level.
 ΔP_t (Pa): Total pressure loss.
 B (m): Distance between diffuser axis for a maximum velocity at the occupied zone of 0.15 m/s, height installation of 2.7 m and ΔT = 0°C.

DFRA



Catalogue Series 40.2

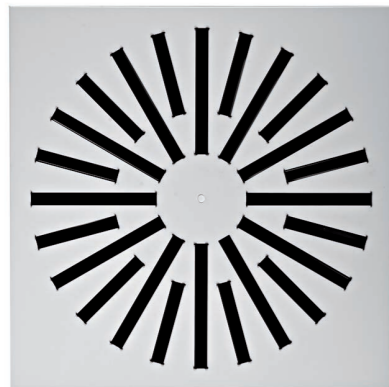

Adjustable blade swirl diffuser

Product description

Adjustable blades radial diffuser, KOOLAIR, model **DFRA**, size $_$, plate dimension of $_x__$. It incorporates a plenum box with side connection made in galvanised steel sheet, with spigot inlet volume control damper. Made in steel sheet. Finished in any RAL colour upon request. Recommended installation height between 2.5 and 3.5 m.

Other models

- DFRA-__60.** Circular diffuser integrated in a plate of 595x595, to be installed in a modular false ceiling (up to size 4860).
- DFRA-E.** Circular swirl diffuser for plaster ceiling plate.
- DFRA-C.** Circular swirl diffuser for circular plate.
- DFRA-AS.** High flow capacity swirl diffuser. Plate size 600 x 600 mm.
- DFRO-A.** Circular swirl diffuser in plate, without blades.

Note: On request, top plenum available insulated/ unisolated (PDS-A-RE/PDS-RE).

Mounting

- PDL-RE.** Plenum with side connection without insulation for square panel, with manual damper accessible from false ceiling.
- PDL-A-RE.** Plenum with side connection internally insulated for square panel, with manual damper accessible from false ceiling.
- PDL-RL.** Plenum with side connection without insulation for square panel, with manual damper accessible from room.
- PDL-A-RL.** Plenum with side connection internally insulated for square panel, with manual damper accessible from room.
- PCDL-RL.** Plenum with side connection without insulation for round panel, with manual damper accessible from room.
- PCDL-A-RL.** Plenum with side connection internally insulated for round panel, with manual damper accessible from room.
- RPM.** Damper equipped to allow motorization.
- PM.** Mounting bridge. To be installed without plenum in plaster ceilings, good for returning air or just decorative.

General dimensions

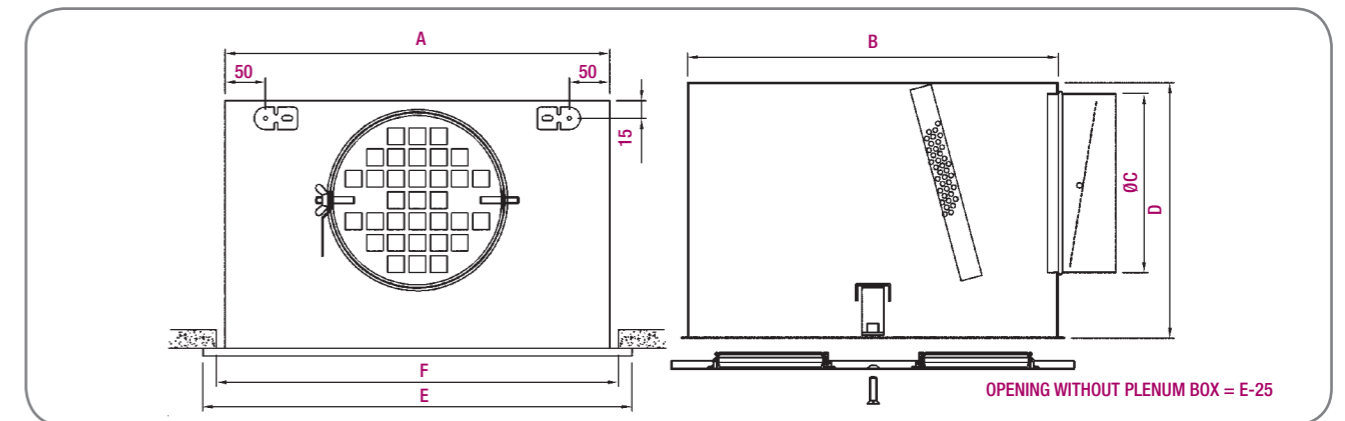

Custom plenums available to suit reduced heights above false ceilings.

Diffuser	A	B	C	D	E	F
12	288	270	159	250	294	290
16	388	370	199	300	394	390
20	488	470	199	300	494	490
24 / 32 / 4860	588	570	249	350	594	590
DFRA-AS 32	588	570	314	410	594	590
36	616	598	249	350	623	618
40	663	645	314 OVAL	350	670	665
48	788	770	314	410	794	790

Unit mm

Selection table

Size	Q (m³/h)	L _{wa} [dB(A)]	ΔP _t (Pa)	B (m)
12	140	24	15	1,3
	190	32	25	1,5
	240	40	43	3,0
16	210	24	8	1,6
	280	32	15	2,5
	380	40	26	3,3
20	300	24	10	2,5
	400	32	18	3,3
	530	40	31	4,3
24	410	24	9	3,2
	550	32	16	4,3
	730	40	28	5,5
32	460	24	10	3,0
	610	32	17	3,8
	810	40	30	4,6
4860	475	24	5	2,9
	632	32	10	4,0
	841	40	17	5,0
DFRA-AS 32	600	24	11	3,7
	800	32	19	4,6
	1070	40	34	5,4
36	490	24	10	2,8
	660	32	18	3,9
	880	40	32	5,0
40	910	24	9	3,2
	810	32	17	4,2
	1080	40	30	5,0
48	730	24	9	3,5
	970	32	17	4,5
	1280	40	29	5,3



LEGEND

Q (m³/h): Air flow.
 L_{wa} [dB(A)]: Sound power level.
 ΔP_t (Pa): Distance between diffuser axis for a maximum velocity at the occupied zone of 0.15 m/s, height installation of 2.7 m and ΔT = 0°C.

DFRA-OV



Catalogue Series DFRA-OV



Adjustable blade Swirl diffuser

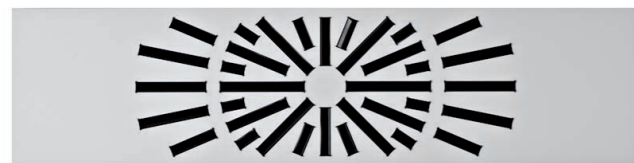

Product description

Oval adjustable blades swirl diffuser, KOOLAIR, model **DFRA-OV**, size _ , dimension plate of 1195x295 mm, to be installed in false ceiling. It incorporates a plenum box with side connection made in galvanised steel sheet, with spigot inlet volume control damper. Made entirely in steel sheet. Finished in any RAL colour upon request.

Other models

DFRA-OV-E. Swirl diffuser integrated in a plate of 1220x320 mm, to be installed in false plaster ceiling.
DFRA-OV dimensions LxH. Swirl diffuser to be integrated in plate of dimension (to be determined) to be installed in false ceiling.

Mounting

PFL-RE. Fixed plenum box without internal insulation, made in galvanised steel sheet.
PFL-A-RE. Fixed plenum box with side connection internally insulated, made in galvanised steel sheet.
PDL-RE. Removable plenum box with side connection, internally non-insulated, made in galvanised steel sheet.
PDL-A-RE. Removable plenum box with side connection, internally insulated, made in galvanised steel sheet.

General dimensions

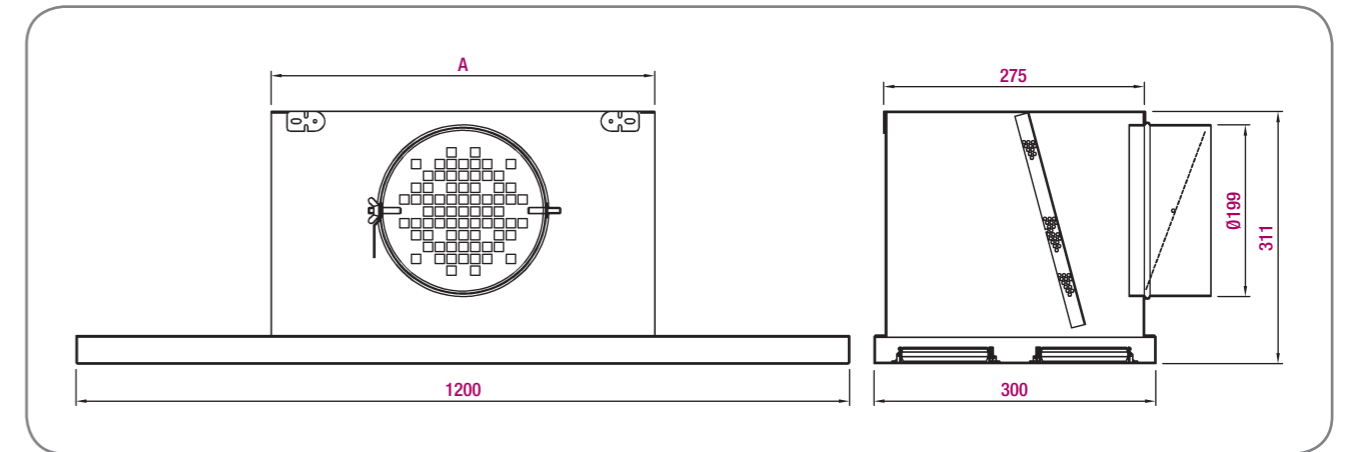

Type	Slots	A
DFRA-OV-12	12	450
DFRA-OV-16	16	450
DFRA-OV-24	24	450
DFRA-OV-34	34	780
DFRA-OV-40	40	1100

Unit mm

Selection table

Size	Q (m³/h)	L _{wa} [dB(A)]	ΔP _t (Pa)	X (m)
12	180	24	9	1,3
	240	32	16	1,7
	310	40	27	2,2
16	190	24	8	1,3
	250	32	10	2,3
	330	40	23	2,2
24	220	24	7	2,0
	290	32	13	2,7
	380	40	17	2,9
34	260	24	8	2,0
	340	32	14	2,6
	440	40	23	3,4
40	290	24	9	2,0
	380	32	16	2,7
	500	40	27	3,4

Available with different number of vanes for greater flow capacity. Consult the Technical Department

LEGEND

Q (m³/h): Air flow.
 L_{wa} [dB(A)]: Sound power level.
 ΔP_t (Pa): Total pressure loss.
 X (m): Throw for a maximum velocity of 0.25 m/s at the occupied zone
 ΔT = -10 °C (cold), installed at 3 m of height, with ceiling effect.



DFRA-OV-44

Adjustable blade swirl diffuser

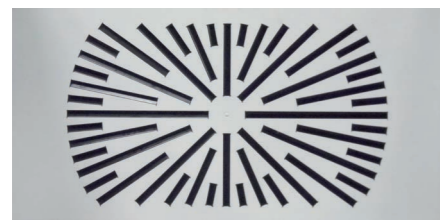

Product description

Oval adjustable blades swirl diffuser, KOOLAIR, model **DFRA-OV-44** (44 slots), dimension plate of 1195x595 mm, to install in modular false ceiling (type T) or another type of profile. It incorporates a plenum of lateral connection, with the option of incorporating a regulating damper in the spigot inlet and accessible from the local. Made entirely in steel sheet. Finished in any RAL colour upon request.

Other models

DFRA-OV-E-44. Swirl diffuser integrated in a plate of 1220x620 mm, to be installed in false plaster ceiling.
DFRA-OV-44. dimensions LxH. Swirl diffuser to be integrated in plate of dimension (to be determined) to be installed in false ceiling.

Mounting

PFL. Fixed plenum box without internal insulation, made in galvanised steel sheet.
PFL-A. Fixed plenum box with side connection internally insulated, made in galvanised steel sheet.

General dimensionss

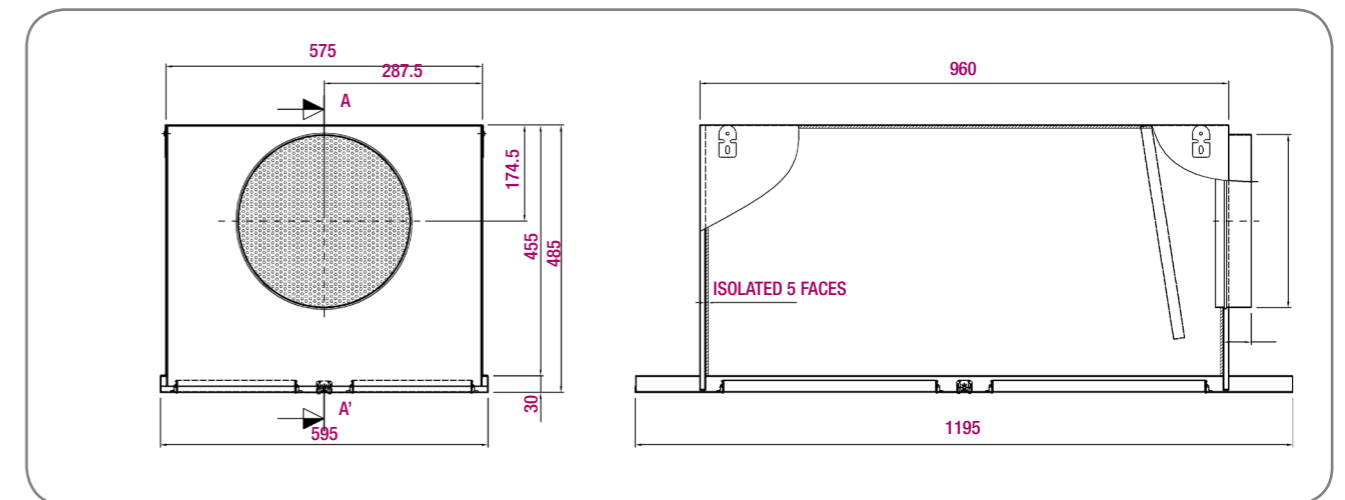

Selection table

Size	Q (m³/h)	L _{wa} [dB(A)]	ΔP _t (Pa)	X (m)
44	970	30	21	2,4
	1250	38	28	3,2
	1600	45	44	4,1

LEGEND

Q (m³/h): Air flow.
 L_{wa} [dB(A)]: Sound power level.
 ΔP_t (Pa): Total pressure loss.
 X (m): Throw for a maximum velocity of 0.25 m/s at the occupied zone
 ΔT = -10 °C (cold), installed at 3 m of height, with ceiling effect.



DFRA-OV-PR

Swirl diffuser with movable blades and perforated plate



Product description

Oval swirl diffuser with movable blades and foldable perforated plate, KOOLAIR model **DFRA-OV-PR**, size \square , plate size 1195x295 mm for installation in modular false ceiling.

Incorporates a galvanized steel plenum with lateral connection. Includes a regulating damper to guarantee correct air distribution.

It is designed and manufactured to adapt to any type of plate and roof profile, including the number of vanes (effective free area) in accordance with the flow rate requirements.

Made entirely of sheet steel. Painted finish in any RAL colour.

Note: On request, top plenum available insulated/uninsulated (PDS-A-RE/PDS-RE).

Other models

DFRA-OV-E-PR. Swirl diffuser integrated in 1220x320 mm plate for installation in plaster false ceilings.

DFRA-OV-PR dimensions LxH. Swirl diffuser integrated in plate, dimensions to be confirmed, for installation in false ceiling.

Mounting

PFL-RE. Fixed plenum box without internal insulation, made in galvanised steel sheet.

PFL-A-RE. Fixed plenum box with side connection internally insulated, made in galvanised steel sheet.

PDL-RE. Removable plenum box with side connection, internally non-insulated, made in galvanised steel sheet.

PDL-A-RE. Removable plenum box with side connection, internally insulated, made in galvanised steel sheet.

General dimensions

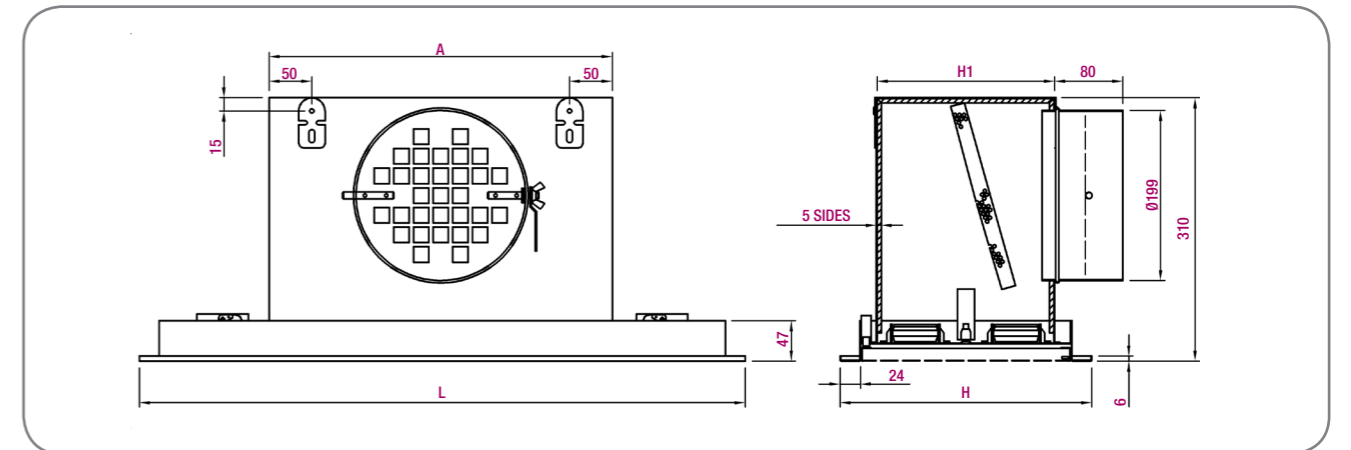

Custom plenums available to suit reduced heights above false ceilings.

Model	Slots	A	H1
DFRA-OV-PR-16	16	450	230
DFRA-OV-PR-24	24	550	230
DFRA-OV-PR-34	34	780	230
DFRA-OV-PR-40	40	1100	230

Unit mm

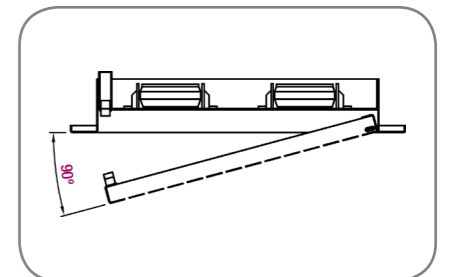

Selection table

Size	Q (m³/h)	L _{WA} [dB(A)]	ΔP _t (Pa)	X (m)
16	185	24	9	1,1
	240	32	11	2,0
	320	40	25	1,9
24	215	24	8	1,7
	280	32	14	2,3
	365	40	19	2,5
34	250	24	9	1,7
	330	32	15	2,2
	425	40	25	2,9
40	275	24	10	1,7
	350	32	16	2,2
	450	40	27	2,8

LEGEND

Q (m³/h): Air flow.
 L_{WA} [dB(A)]: Sound power level.
 ΔP_t (Pa): Total pressure loss.
 X (m): Throw for a maximum velocity of 0.25 m/s at the occupied zone
 ΔT = -10 °C (cold), installed at 3 m of height, with ceiling effect.

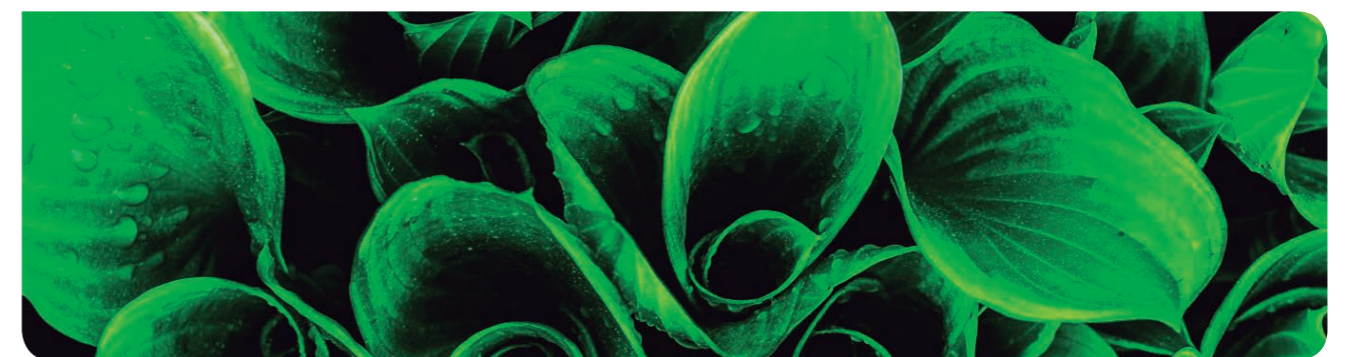

DFRQ



Catalogue Series 40.2

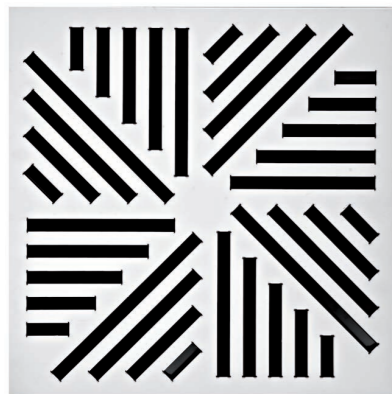

Adjustable blade swirl diffuser

Product description

Adjustable blades swirl diffuser, KOOLAIR, model **DFRQ**, size $_x_$, plate dimension of $_x_$. Incorporates side connection plenum box made in galvanised steel sheet, with spigot inlet volume control damper. Made in steel sheet. Finished in any RAL colour upon request.

Recommended installation height between 2.5 and 3.5 m.

Other models

DFRQ-__60. Swirl diffuser integrated in plate of 595x595 mm, to be installed in false ceiling (**till size 36**).

DFRQ-E. Circular swirl diffuser for plaster ceiling plate.

Note: On request, top plenum available insulated/ unisolated (PDS-A-RE/PDS-RE).

Mounting

PDL-RE. Plenum with side connection without insulation for square panel, with manual damper accessible from false ceiling.

PDL-A-RE. Plenum with side connection internally insulated for square panel, with manual damper accessible from false ceiling.

PDL-RL. Plenum with side connection without insulation for square panel, with manual damper accessible from room.

PDL-A-RL. Plenum with side connection internally insulated for square panel, with manual damper accessible from room.

PCDL-RL. Plenum with side connection without insulation for round panel, with manual damper accessible from room.

PCDL-A-RL. Plenum with side connection internally insulated for round panel, with manual damper accessible from room.

RPM. Damper equipped to allow motorization.

PM. Mounting bridge. To be installed without plenum in plaster ceilings, good for returning air or just decorative.

General dimensions

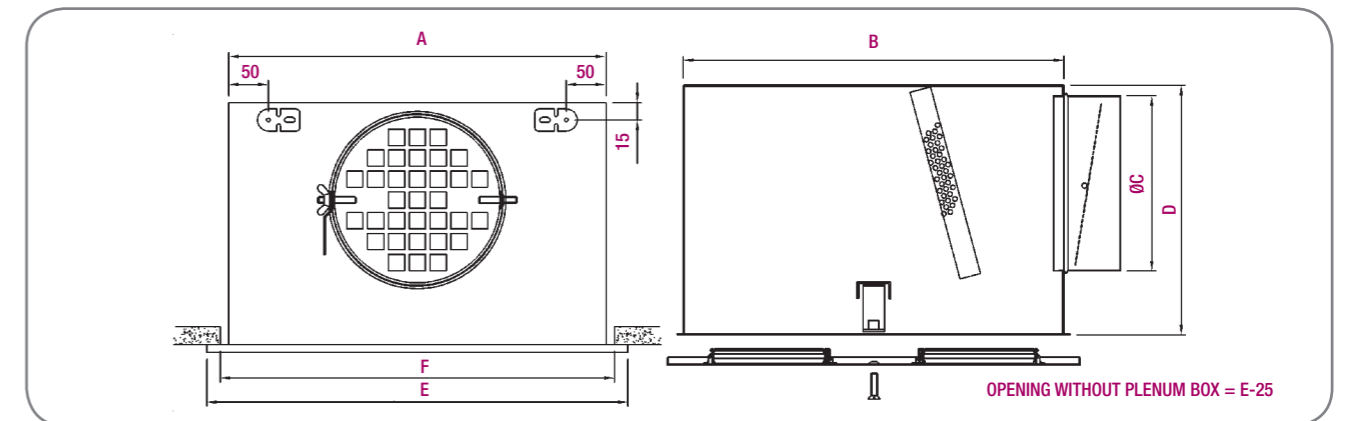

Custom plenums available to suit reduced heights above false ceilings.

Diffuser	A	B	C	D	E	F
28	488	470	199	300	494	490
36	588	570	249	350	594	590
40	663	645	314 OVAL	350	670	665
48	788	770	314	410	794	790

Unit mm

Selection table

Size	Q (m³/h)	L _{WA} [dB(A)]	ΔP _t (Pa)	B (m)
28	340	24	12	2.8
	450	32	21	3.8
	580	40	34	5.0
36	540	24	12	3.0
	700	32	20	4.0
	900	40	34	5.0
40	570	24	10	3.5
	870	32	17	4.3
	1130	40	29	5.0
48	790	24	11	3.5
	1030	32	18	4.3
	1330	40	30	5.2

LEGEND

Q (m³/h): Air flow.

L_{WA} [dB(A)]: Sound power level.

ΔP_t (Pa): Total pressure loss.

X (m): Distance between diffuser axis for a maximum velocity at the occupied zone of 0.15 m/s, height installation of 2.7 m and ΔT = 0°C.



DF-TR-R/DF-TR-V Catalogue Series DF-TR



DFTR-R



Thermo-adjustable swirl diffuser

Product description

Variable geometry swirl diffuser, KOOLAIR, model **DF-TR-R / DF-TR-V**, plate dimension of 595x595 mm, thermally regulated without the need of a motor, to supply hot air vertically and cold air horizontally. It includes connection plenum box made in galvanised steel sheet, with volume control damper. Finished in any RAL colour upon request. Recommended height installation between 3.5 to 5 m for **DF-TR-R** model. Recommended height installation between 4.5 to 8 m for **DF-TR-V** model.

Other models

DFTR-R-E / DFTR-V-E. Thermo-adjustable circular swirl diffuser for plaster ceiling plate.
DFTR-R-C / DFTR-V-C. Thermo-adjustable swirl diffuser integrated in round plate of Ø 595 mm.

Mounting

PDL-RE. Plenum with side connection without insulation for square panel, with manual damper accessible from false ceiling.
PDL-A-RE. Plenum with side connection internally insulated for square panel, with manual damper accessible from false ceiling.
PDL-RL. Plenum with side connection without insulation for square panel, with manual damper accessible from room.
PDL-A-RL. Plenum with side connection internally insulated for square panel, with manual damper accessible from room.
PCDL-RL. Plenum with side connection without insulation for round panel, with manual damper accessible from room.
PCDL-A-RL. Plenum with side connection internally insulated for round panel, with manual damper accessible from room.

Note: On request, top plenum available insulated/ uninsulated (PDS-A-RE/PDS-RE).

General dimensions

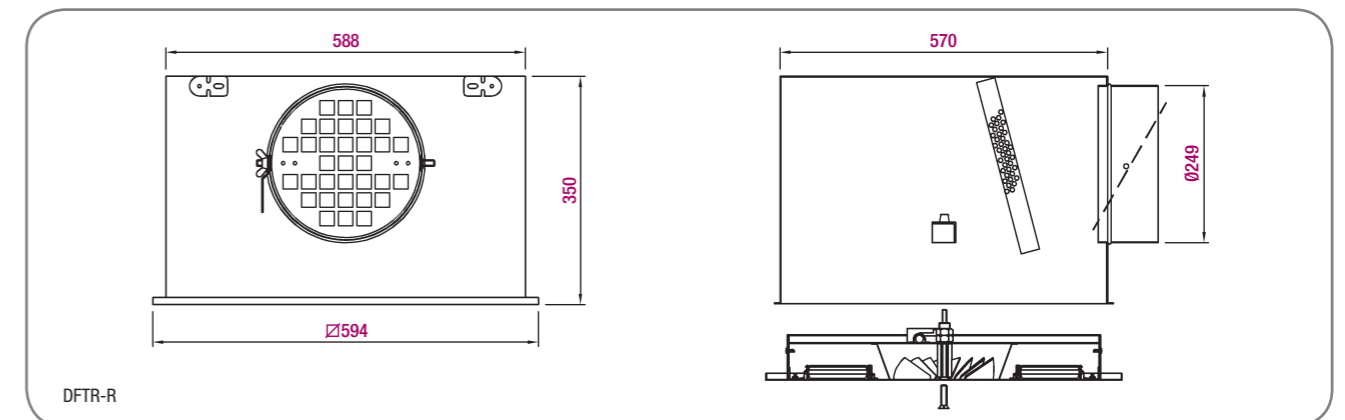

Custom plenums available to suit reduced heights above false ceilings.

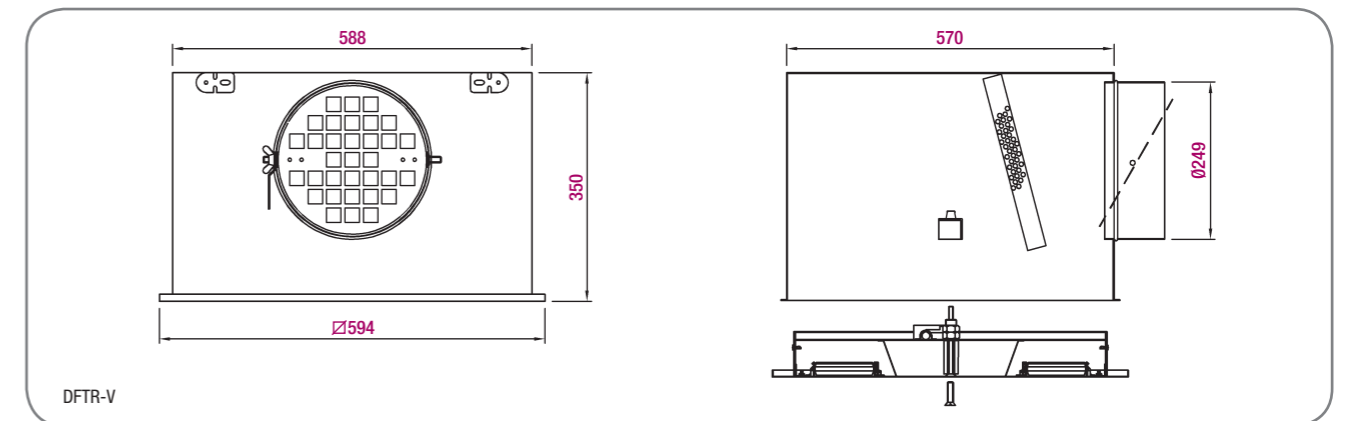

Custom plenums available to suit reduced heights above false ceilings.

Selection table (horizontal discharge)

Q (m³/h)	L _{wa} [dB(A)]	ΔP _t (Pa)	X (m)
500	32	18	2.4
670	40	31	3.2
900	48	55	4.3

Selection table DFTR-R (vertical discharge)

Q (m³/h)	L _{wa} [dB(A)]	ΔP _t (Pa)	Y _{0.5} (m)	Y _{0.3} (m)	Y _{max} (m)
440	32	21	2.2	2.7	3.1
570	40	34	2.9	3.6	4.0
750	48	59	3.7	4.7	5.2

Selection table DFTR-V (vertical discharge)

Q (m³/h)	L _{wa} [dB(A)]	ΔP _t (Pa)	Y _{0.5} (m)	Y _{0.3} (m)	Y _{max} (m)
450	32	23	2.9	3.4	3.7
600	40	40	3.9	4.6	4.9
810	48	72	5.3	6.2	6.6

LEGEND

Q (m³/h): Air flow.
 L_{wa} [dB(A)]: Sound power level.
 ΔP_t (Pa): Total pressure loss.
 X (m): Throw for a maximum velocity of 0.25 m/s at the occupied zone
 ΔT = 0 °C et hauteur de l'installation 3 m.
 Y_{0.5} - Y_{0.3} - Y_{max} (m): Vertical penetration for a maximum air vein velocity of 0.5, 0.3 and 0 m/s respectively and ΔT = +10° C (hot).

DAFC



Catalogue Series 40.3



Fixed curved blade Swirl diffuser

Product description

Swirl diffuser with fixed curved blades, KOOLAIR, model **DAFC**, size _ , plate dimensions of _x_. Incorporates plenum box made of galvanised steel sheet with volume control damper. Made in steel sheet. Finished in any RAL colour upon request. Recommended installation height between 2.5 and 3.5 m.

Other models

- DAFC-Q.** Swirl diffuser with fixed curve blades, integrated in plate of 595x595 mm, to be installed in false ceiling.
- DAFC-C.** Swirl diffuser with fixed curve blades, integrated in round plate.
- DAFC-E.** Swirl diffuser with fixed curve blades, integrated in plate to be installed in plaster ceiling.
- DAFC-Q-PR.** Swirl diffuser with fixed curve blades, integrated in perforated plate dimensions 595x595 mm.

Mounting

- PCDL-RE.** Removable plenum box with side connection, internally non-insulated, made in galvanised steel sheet, with manual damper accessible from false ceiling.
- PCDL-A-RE.** Removable plenum box with side connection, internally insulated, made in galvanised steel sheet, with manual damper accessible from false ceiling.
- PCDL-RL.** Removable plenum box with side connection, internally non-insulated, made in galvanised steel sheet, with manual damper accessible from room.
- PCDL-A-RL.** Removable plenum box with side connection, internally insulated, made in galvanised steel sheet, with manual damper accessible from room.
- RPM.** Damper equipped to allow motorization.
- PM.** Mounting bridge. To be used when installation is without a plenum.

General dimensions

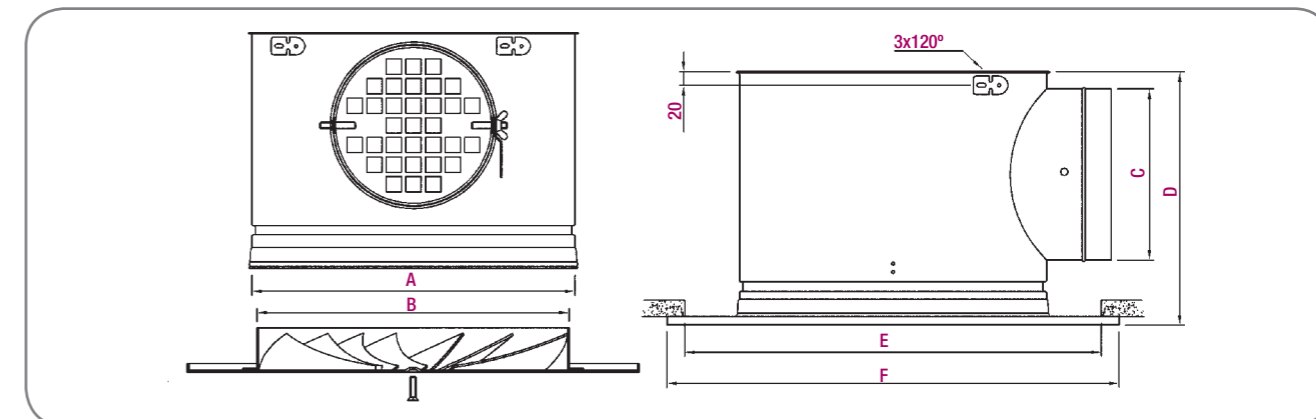

Custom plenums available to suit reduced heights above false ceilings.

Type	A	B	C	D	E	F
125	138	124	99	171	146	171
160	173	159	124	196	188	213
200	213	199	159	231	239	264
250	263	249	199	271	301	326
315	328	314	199	271	380	405
355	368	354	249	321	430	455
400	413	399	249	321	485	510
500	513	499	314	386	569	594

Unit mm

Selection table

Size	Q (m³/h)	L _{wa} [dB(A)]	ΔP _t (Pa)	X (m)
125	40	24	11	0.5
	50	32	21	0.7
	70	40	38	0.9
160	50	24	9	0.6
	80	32	17	0.9
	100	40	32	1.2
200	80	24	7	0.8
	110	32	14	1.1
	160	40	27	1.6
250	110	24	5	1.0
	160	32	11	1.4
	230	40	21	1.9
315	190	24	8	1.3
	250	32	15	1.8
	340	40	27	2.4
355	220	24	7	1.4
	300	32	13	1.9
	410	40	24	2.6
400	250	24	6	1.4
	340	32	12	2.0
	470	40	22	2.7
500	350	24	6	1.7
	480	32	12	2.2
	650	40	22	3.0



LEGEND

Q (m³/h): Air flow.
 L_{wa} [dB(A)]: Sound power level.
 ΔP_t (Pa): Total pressure loss.
 X (m): Throw for a maximum velocity of 0.25 m/s at the occupied zone
 ΔT = -10 °C (cold), installed at 3 m of height.



Fixed Blade Swirl diffuser

Product description

Fixed blade swirl diffuser, KOOLAIR, model **DFRE**, size $_x$, plate dimension of $_x$. Incorporates side connection plenum box made in galvanised steel sheet, with volume control damper on the spigot. Made in steel sheet. Finished in any RAL colour upon request.

Recommended installation height between 2.5 and 3.5 m.

Other models

DFRE-Q. Fixed blade swirl diffuser integrated in plate of 595x595 mm, to be installed in false ceiling.

DFRE-C. Fixed blade swirl diffuser integrated in round plate.

DFRE-E. Fixed blade swirl diffuser integrated in plaster ceiling.

Mounting

PCDL-RE. Removable plenum box with side connection, internally non-insulated, made in galvanised steel sheet, with manual damper accessible from false ceiling.

PCDL-A-RE. Removable plenum box with side connection, internally insulated, made in galvanised steel sheet, with manual damper accessible from false ceiling.

PCDL-RL. Removable plenum box with side connection, internally non-insulated, made in galvanised steel sheet, with manual damper accessible from room.

PCDL-A-RL. Removable plenum box with side connection, internally insulated, made in galvanised steel sheet, with manual damper accessible from room.

RPM. Damper equipped to allow motorization.

PM. Mounting bridge. To be used when installation is without a plenum.

Note: On request, top plenum available insulated/ unisulated (PDS-A-RE/PDS-RE).

General dimensions

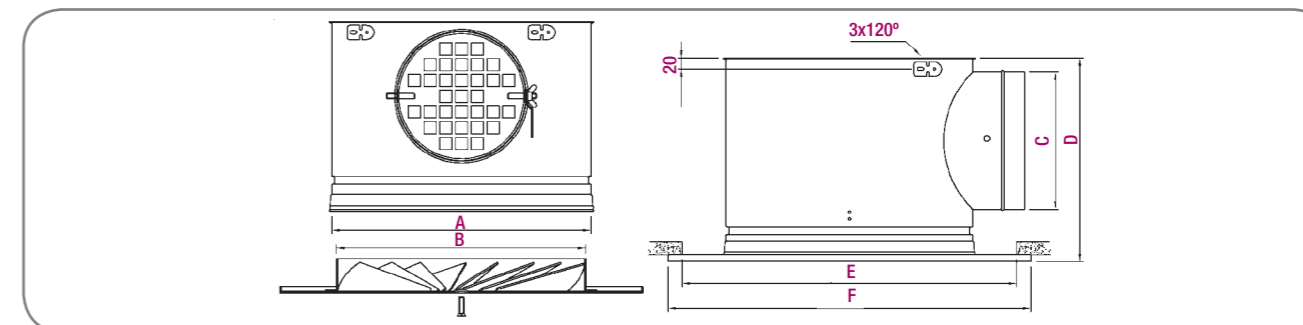

Custom plenums available to suit reduced heights above false ceilings.

Type	Ø A	Ø B	Ø C	D	E	F
100	113	99	99	171	127	152
125	138	124	99	171	146	171
160	173	159	124	196	188	213
200	213	199	159	231	239	264
250	263	249	199	271	301	326
315	328	314	249	321	380	405
355	368	354	249	321	430	455
400	413	399	314	386	485	510
500	513	499	314	386	569	594

Unit mm

Selection table

Size	Q (m³/h)	L _{WA} [dB(A)]	ΔP _t (Pa)	X (m)
100	40	24	17	0,5
	58	32	35	0,7
	82	40	70	0,9
125	47	24	12	0,4
	70	32	26	0,6
	95	40	47	0,9
160	65	24	10	0,5
	95	32	22	0,8
	135	40	44	1,1
200	115	24	9	0,8
	165	32	19	1,1
	235	40	38	1,6
250	170	24	8	1,0
	245	32	17	1,5
	350	40	34	2,1
315	310	24	7	1,6
	440	32	15	2,2
	625	40	30	3,1
355	350	24	8	1,7
	500	32	16	2,4
	710	40	32	3,4
400	600	24	12	2,7
	830	32	23	3,8
	1200	40	48	5,5
500	825	24	14	2,9
	1200	32	30	4,2
	1650	40	57	5,8



LEGEND

Q (m³/h): Air flow.

L_{WA} [dB(A)]: Sound power level.

ΔP_t (Pa): Total pressure loss.

X (m): Throw for a maximum velocity of 0.25 m/s at the occupied zone ΔT = -10 °C (cold), installed at 3 m of height.

DFRE-GR



Catalogue Series 40.3



Fixed Blade Swirl diffuser

Product description

Fixed blade swirl diffuser with external coanda ring, KOOLAIR, model **DFRE-GR**, dimension \varnothing . Incorporates side connection plenum box made in galvanised steel sheet, with spigot inlet volume control damper. Diffuser made in steel sheet and decorative ring in aluminum. Finished in any RAL colour upon request. Recommended installation height between 2.5 and 3.5 m and ideal for circular visible ducts.

Other models

DFRE-GR-Q. Swirl diffuser with external coanda ring, integrated in plate of 595x595 mm to be installed in false ceilings.

Mounting

PCDL-RE. Removable plenum box with side connection, internally non-insulated, made in galvanised steel sheet, with manual damper accessible from false ceiling.

PCDL-A-RE. Removable plenum box with side connection, internally insulated, made in galvanised steel sheet, with manual damper accessible from false ceiling.

PCDL-RL. Removable plenum box with side connection, internally non-insulated, made in galvanised steel sheet, with manual damper accessible from room.

PCDL-A-RL. Removable plenum box with side connection, internally insulated, made in galvanised steel sheet, with manual damper accessible from room.

RPM. Damper equipped to allow motorization.

PM. Mounting bridge. To be used when installation is without a plenum.

Note: On request, top plenum available insulated/ uninsulated (PDS-A-RE/PDS-RE).

General dimensions

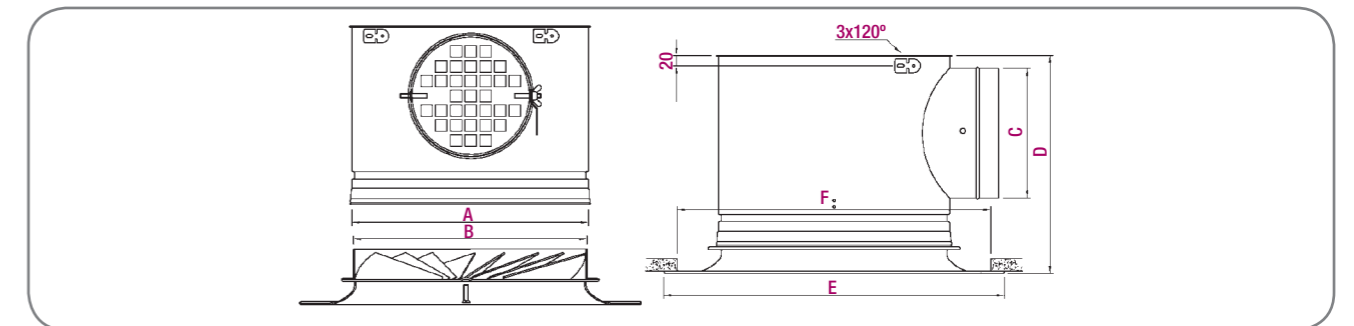

Custom plenums available to suit reduced heights above false ceilings.

Model	A	B	C	D	E	F
100	113	99	99	171	175	150
125	138	124	99	171	200	175
160	173	159	124	196	253	228
200	213	199	159	231	303	278
250	263	249	199	271	353	328
315	328	314	249	321	418	393
355	368	354	249	321	458	433
400	413	399	314	386	503	478
500	513	499	314	386	603	578

Unit mm

Selection table

Size	Q (m³/h)	L _{WA} [dB(A)]	ΔP _t (Pa)	X (m)
100	40	24	7	0,5
	55	32	14	0,7
	80	40	30	1,0
125	55	24	12	0,6
	78	32	24	0,9
	110	40	48	1,2
160	80	24	13	0,7
	115	32	27	1,0
	160	40	52	1,4
200	125	24	13	0,9
	175	32	26	1,3
	245	40	51	1,9
250	190	24	10	1,2
	260	32	19	1,6
	375	40	40	2,3
315	330	24	8	1,6
	460	32	16	2,2
	660	40	32	3,1
355	375	24	7	1,6
	575	32	14	2,3
	740	40	28	3,2
400	485	24	8	1,9
	660	32	14	2,5
	925	40	28	3,6
500	640	24	6	2,0
	890	32	12	2,8
	1250	40	23	4,0

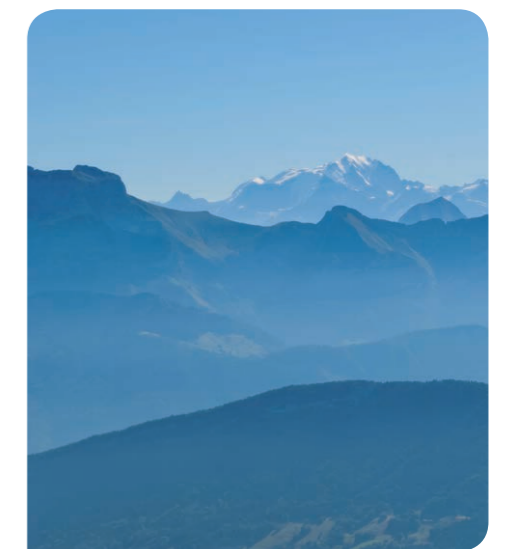

LEGEND

Q (m³/h): Air flow.
 L_{WA} [dB(A)]: Sound power level.
 ΔP_t (Pa): Total pressure loss.
 X (m): Throw for a maximum velocity of 0.25 m/s at the occupied zone ΔT = -10 °C (cold), installed at 3 m of height.

DAFT



Catalogue Series 40.3

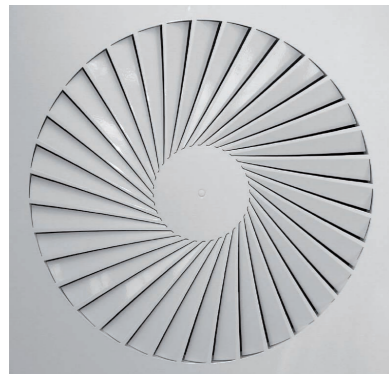

Fixed blade swirl diffuser

Product description

Fixed blade swirl diffuser KOOLAIR model **DAFT**, size **_x_** integrated into a plate 595x595, incorporate connection plenum box made in galvanised steel, with volume control damper on the spigot. Finished in any RAL colour upon request. Recommended installation height between 2.5 and 3.5 m.

Other models

DAFT-Q. Fixed blade swirl diffuser integrated into a plate 595x595 mm, for tile replacement.

DAFT-C. Fixed blade swirl diffuser integrated into a circular plate.

Mounting

PCDL-RE. Removable plenum box with side connection, internally non-insulated, made in galvanised steel sheet, with manual damper accessible from false ceiling.

PCDL-A-RE. Removable plenum box with side connection, internally insulated, made in galvanised steel sheet, with manual damper accessible from false ceiling.

PCDL-RL. Removable plenum box with side connection, internally non-insulated, made in galvanised steel sheet, with manual damper accessible from room.

PCDL-A-RL. Removable plenum box with side connection, internally insulated, made in galvanised steel sheet, with manual damper accessible from room.

RPM. Damper equipped to allow motorization.

PM. Mounting bridge. To be used when installation is without a plenum.

Note: On request, top plenum available insulated/ uninsulated (PDS-A-RE/PDS-RE).

General dimensions

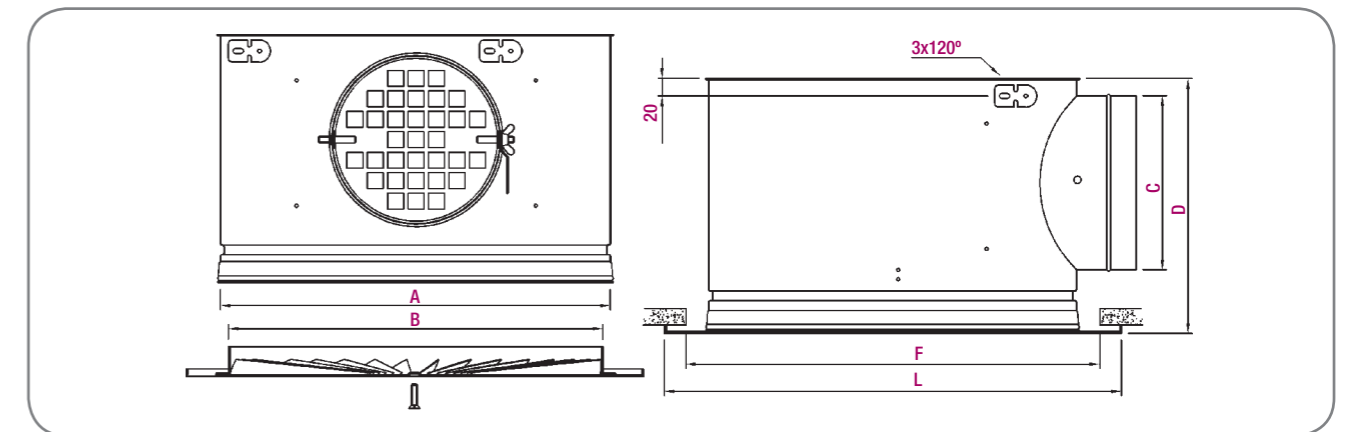

Custom plenums available to suit reduced heights above false ceilings.

Model	L	A	B	C	D	F
300	298	273	260	159	229	273
325	323	273	260	159	229	298
400	398	356	344	199	269	373
500	498	450	438	199	269	473
600	595	553	541	249	319	570
625	623	553	541	249	319	598

Unit mm

Selection table

Size	Q (m³/h)	L _{WA} [dB(A)]	ΔP _t (Pa)	X (m)
300/(325)	90	24	6	1.0
	125	32	12	1.4
	180	40	25	2.0
400	190	24	7	1.5
	275	32	15	2.0
	375	40	27	3.0
500	260	24	8	1.7
	370	32	16	2.4
	500	40	28	3.2
600/(625)	350	24	7	1.9
	480	32	14	2.7
	700	40	26	3.9

LEGEND

Q (m³/h): Air flow.

L_{WA} [dB(A)]: Sound power level.

ΔP_t (Pa): Total pressure loss.

X (m): Throw for a maximum velocity of 0.25 m/s at the occupied zone ΔT = -10 °C (cold), installed at 3 m of height.

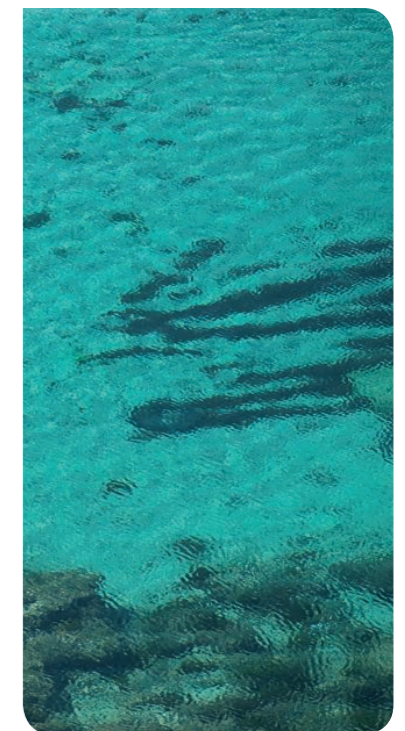

DFRT



Catalogue Series 40.3



Fixed blade swirl diffuser

Product description

Fixed blade swirl diffuser KOOLAIR model **DFRT**, size *_x_* integrated into a plate 595x595, incorporate connection plenum box made in galvanised steel, with volume control damper on the spigot. Finished in any RAL colour upon request.

Other models

DFRT-Q. Fixed blade swirl diffuser integrated into a plate 595x595 mm, for tile replacement.

DFRT-C. Fixed blade swirl diffuser integrated into a circular plate.

Mounting

PCDL-RE. Removable plenum box with side connection, internally non-insulated, made in galvanised steel sheet, with manual damper accessible from false ceiling.

PCDL-A-RE. Removable plenum box with side connection, internally insulated, made in galvanised steel sheet, with manual damper accessible from false ceiling.

PCDL-RL. Removable plenum box with side connection, internally non-insulated, made in galvanised steel sheet, with manual damper accessible from room.

PCDL-A-RL. Removable plenum box with side connection, internally insulated, made in galvanised steel sheet, with manual damper accessible from room.

RPM. Damper equipped to allow motorization.

PM. Mounting bridge. To be used when installation is without a plenum.

Note: On request, top plenum available insulated/ uninsulated (PDS-A-RE/PDS-RE).

General dimensions

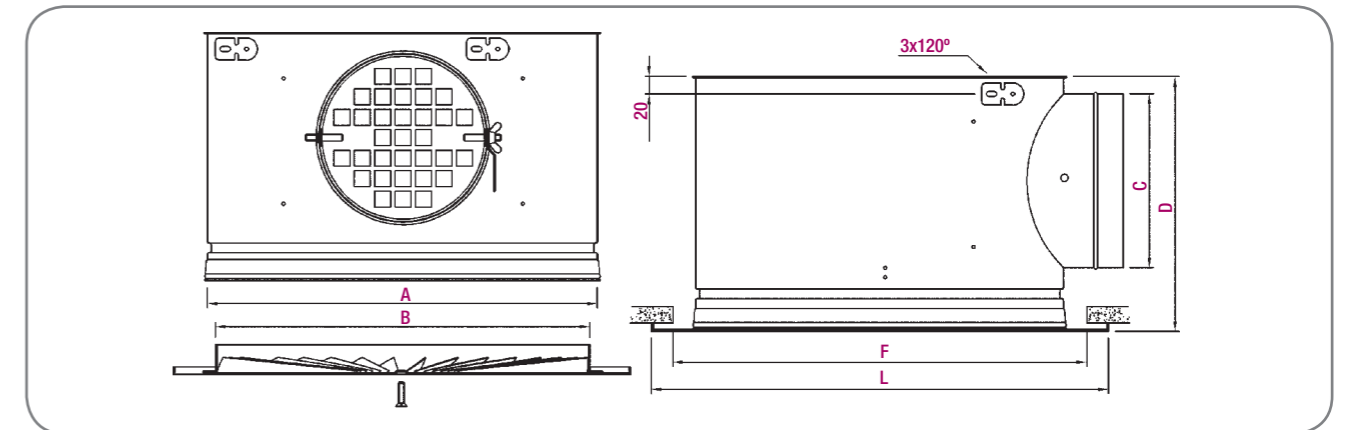

Custom plenums available to suit reduced heights above false ceilings.

Model	L	A	B	C	D	F
300	298	273	260	159	230	283
325	323	304	294	159	230	314
400	398	370	358	199	270	380
500	498	413	402	199	270	423
600	595	546	533	249	320	556
625	623	546	533	249	320	556

Unit mm

Selection table

Size	Q (m³/h)	L _{wa} [dB(A)]	ΔP _t (Pa)	X (m)
300	90	24	9	1,0
	130	32	18	1,2
	180	40	35	1,8
325	120	24	8	1,0
	170	32	17	1,5
	250	40	37	2,0
400	200	24	8	1,3
	280	32	16	1,8
	400	40	33	2,6
500	270	24	8	1,4
	420	32	19	2,2
	550	40	32	2,9
600/(625)	400	24	7	1,6
	600	32	15	2,5
	800	40	26	3,3

LEGEND

Q (m³/h): Air flow.

L_{wa} [dB(A)]: Sound power level.

ΔP_t (Pa): Total pressure loss.

X (m): Throw for a maximum velocity of 0.25 m/s at the occupied zone ΔT = -10 °C (cold), installed at 3 m of height.



DFRE-GR-TR



Catalogue Series DFRE-GR-TR



Adjustable Blade Swirl diffuser

Product description

Adjustable blade swirl diffuser, KOOLAIR, model **DFRE-GR-TR**, available from Ø160 to Ø500 (temperature-adjustable version). It can incorporate side entry plenum box, with volume control damper on the spigot or direct conexión against circular duct. Made in steel sheet. Finished in any RAL colour upon request. Recommended installation height between 3.5 and 6 m.

Other models

DFRE-GR-RM. Swirl diffuser with manually adjustable movable blades, Ø160 to Ø500 (manual version).
DFRE-GR-TR-Q. Thermo-adjustable swirl diffuser integrated in 595x595 mm plate for installation in modular false ceilings.
DFRE-GR-RM-Q. Swirl diffuser with manually adjustable movable blades integrated in 595x595 mm plate for installation in modular false ceilings.

DFRE-GR-PR-TR. Thermo-adjustable swirl diffuser integrated in punched plate of dimensions LxH to be installed in false ceiling.
DFRE-GR-TR-PR-C. Thermo-adjustable swirl diffuser integrated in circular punched plate.

Mounting

PCFL-RE. Fixed plenum box without internal insulation, with manual damper.
PCFL-A-RE. Fixed plenum box with side connection internally insulated, with manual damper.

Note: On request, top plenum available insulated/ unisulated (PCFS-A-RE/PCFS-RE).



General dimensions

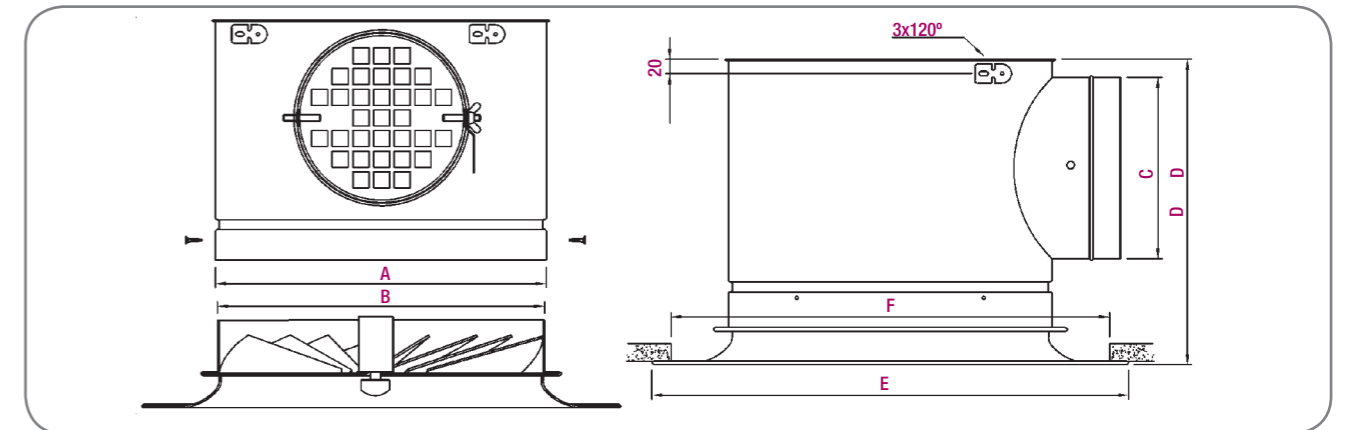

Custom plenums available to suit reduced heights above false ceilings.

Model	A	B	C	D	E	F
160	165	159	124	320	253	228
200	205	199	159	355	303	278
250	255	249	199	395	353	328
315	320	314	249	445	418	393
355	360	354	249	445	458	433
400	405	399	314	510	503	478
500	505	499	314	510	603	578

Unit mm

Selection table (Vertical discharge)

Size	Q (m³/h)	L _{wa} [dB(A)]	ΔP _t (Pa)	Y (m)
160	250	25	14	2,6
	350	35	27	3,7
	475	45	50	5,0
200	370	25	13	3,1
	500	35	23	4,2
	660	45	40	5,5
250	540	25	11	3,6
	730	35	20	4,9
	975	45	36	6,5
315	800	25	9	4,3
	1075	35	17	5,7
	1480	45	32	7,9
355	850	25	10	4,0
	1175	35	20	5,5
	1600	45	36	7,5
400	950	25	9	3,7
	1300	35	17	5,1
	1800	45	33	7,1
500	1050	25	5	3,1
	1450	35	10	4,3
	1950	45	18	5,8

Selection table (Horizontal discharge)

Size	Q (m³/h)	L _{wa} [dB(A)]	ΔP _t (Pa)	X (m)
160	85	25	15	0,8
	130	35	34	1,2
	195	45	78	1,7
200	130	25	14	1,0
	195	35	32	1,5
	300	45	76	2,3
250	200	25	11	1,2
	300	35	26	1,9
	460	45	61	2,8
315	350	25	9	1,7
	515	35	20	2,4
	775	45	46	3,7
355	395	25	8	1,7
	600	35	18	2,6
	900	45	42	3,9
400	500	25	8	1,9
	765	35	19	2,9
	1150	45	43	4,4
500	650	25	6	2,1
	975	35	14	3,1
	1500	45	34	4,8

LEGEND

Q (m³/h): Air flow.
L_{wa} [dB(A)]: Sound power level.
ΔP_t (Pa): Total pressure loss.

Y (m): Vertical penetration for a terminal air vein velocity of 0.25 m/s and ΔT = +10° C (hot).
X (m): Throw for a maximum velocity of 0.25 m/s at the occupied zone ΔT = -10° C (cold), installed at 3 m of height

DRLT



Hidden fixed blade swirl diffuser

Product description

KOOLAIR fixed-blade swirl diffuser, model **DRLT-LxH**, size $_x\$, to be incorporated in a $_x\$ mm micro-perforated ceiling tile. Suitable for use with a lateral connection plenum complete with regulating damper that can be accessed from the false ceiling. 1200 x 300 mm tiles can incorporate a diffuser up to $\varnothing 250$.

Available or adaptable to micro-perforated ceiling tiles suspended with a free area between 16% and 30% covering a large part of the range of existing standard micro-perforated ceilings on the market.

Diffuser and micro-perforated tile manufactured from sheet steel. Ceiling tile with a painted finish in RAL colour to be defined; diffuser in RAL-9005 (black) to prevent it from being seen and guarantee discretion. They achieve one of the design premises most sought after by architects and designers: to completely hide the components of the air conditioning installation. The air diffusion unit is integrated above the micro-perforated ceiling tiles (inside the false ceiling), giving total aesthetic uniformity to the space.

For correct operation in both heating and cooling an installation height between 2.4 and 3 m is recommended.

Other models

DRLT-Q. Swirl diffuser to be incorporated in existing 595x595 mm micro-perforated false ceiling tile.

DRLT-PR-Plate LxH. Swirl diffuser integrated in $_x\$ m micro-perforated tile. 1200x300 mm tiles can incorporate a diffuser up to $\varnothing 250$.

DRLT-PR-Q. Swirl diffuser integrated in an existing microperforated plate of dimensions 595x595 mm in a false ceiling.

Mounting

PCDL-RE. Removable plenum box with side connection, internally non-insulated, made in galvanised steel sheet, with manual damper accessible from false ceiling.

PCDL-A-RE. Removable plenum box with side connection, internally insulated, made in galvanised steel sheet, with manual damper accessible from false ceiling.

Note: On request, top plenum available insulated/ uninsulated (PDS-A-RE/PDS-RE).

General dimensions

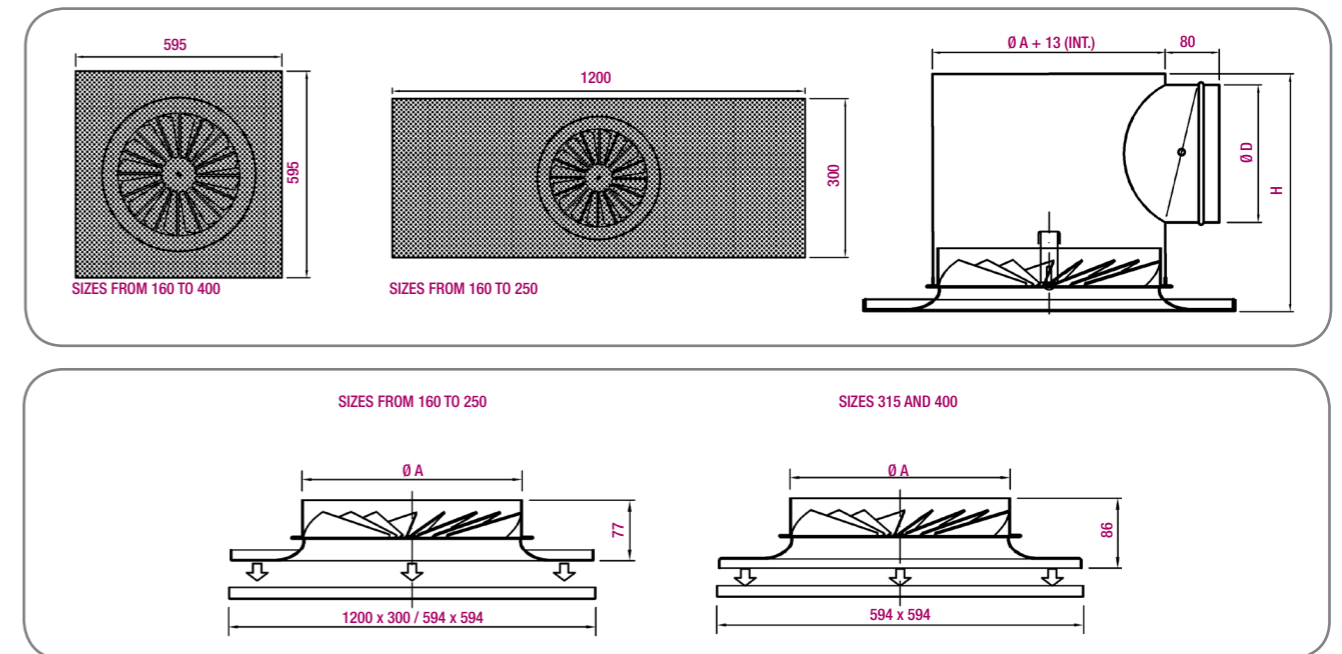

Custom plenums available to suit reduced heights above false ceilings.

Diffuser	Ø A	Ø D	H
160	158	124	221
200	198	159	256
250	248	199	296
315	313	249	355
400	398	249	355

Unit mm

Selection table

Diffuser	Q (m³/h)	L _{wa} [dB(A)]	ΔP _t (Pa)	X (m)	V _k (m/s)
160	85	24	10	0,4	1,4
	115	32	19	0,6	1,9
	160	40	36	0,8	2,6
200	120	24	10	0,5	1,6
	165	32	18	0,7	2,1
	225	40	33	1,0	2,9
250	160	24	9	0,7	1,7
	220	32	16	1,0	2,4
	300	40	31	1,4	3,2
315	275	24	5	1,0	2,6
	375	32	10	1,4	3,5
	510	40	19	1,9	4,7
400	320	24	6	1,2	2,3
	430	32	12	1,6	3,2
	590	40	22	2,2	4,3

LEGEND

Q (m³/h): Air flow.

L_{wa} [dB(A)]: Sound power level.

ΔP_t (Pa): Total pressure loss.

X (m): Throw for a maximum velocity of 0.25 m/s at the occupied zone

ΔT = -10 °C (cold), installed at 2.8 m of height.

V_k (m/s): Effective velocity.

Technical data for micro-perforated tile with 16% free area.

Availability of other perforation designs. Consult the Technical Department.

DFRE-GR-PR



Catalogue Series 40.3

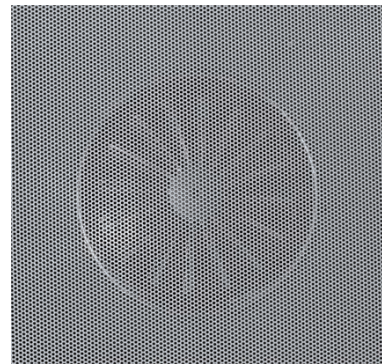

Fixed Blade Swirl diffuser

Product description

Fixed blade swirl diffuser, KOOLAIR, model **DFRE-GR-PR-Q**, size $_$, integrated in hinged perforated plate of dimensions 595x595 mm. Incorporates side connection plenum box and volume control damper. Made in steel sheet. Finished in any RAL colour upon request. Recommended installation height between 2.5 and 3.5 m.

Other models

DFRE-GR-PR dimensions LxH. Swirl diffuser integrated in punched plate of dimensions $_x_$ to be installed in false ceiling.
DFRE-GR-PR-C. Swirl diffuser integrated in circular punched plate. The perforated plate and the swirl diffuser are not removable.
DFRE-GR-Q-PR. Swirl diffuser with no outer ring integrated in 595x595 mm perforated foldable plate. Incorporates side connection plenum box and volume control damper.

Mounting

PCFL-RE. Fixed plenum box without internal insulation, with manual damper.
PCFL-A-RE. Fixed plenum box with side connection internally insulated, with manual damper.

Note: On request, top plenum available insulated/ uninsulated (PCFS-A-RE/PCFS-RE).



General dimensions

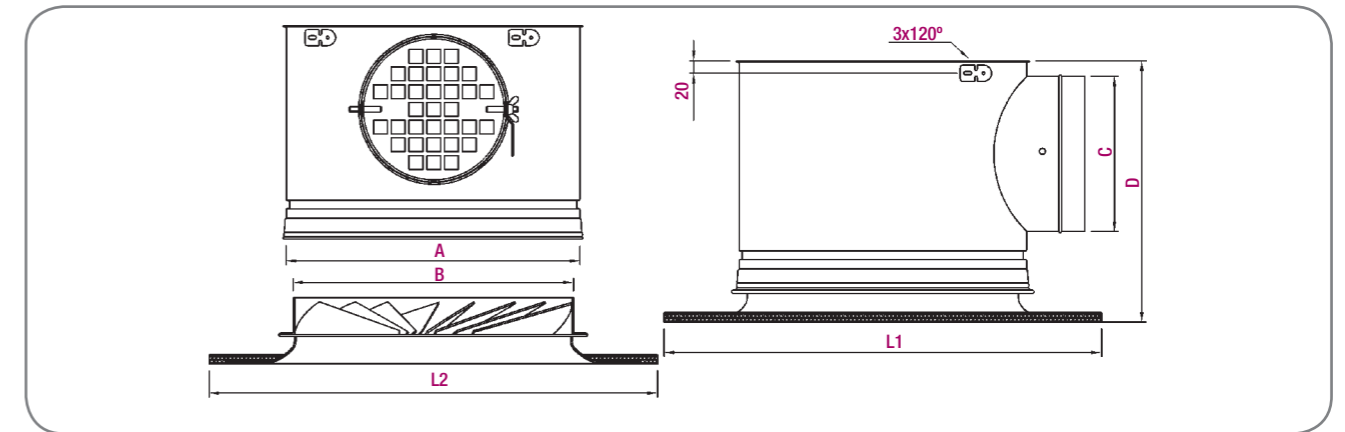

Custom plenums available to suit reduced heights above false ceilings.

Type	A	B	C	D	DFRE-GR-PR L1 x L2	DFRE-GR-Q-PR L1 x L2
125	130	124	99	198	594 x 1194 625 x 625	594 x 594
160	165	159	124	223		
200	205	199	159	258		
250	255	249	199	298		
315	320	314	199	298		
355	360	354	249	348		
400	405	399	249	348		
500	505	499	314	413		

Unit mm

Selection table

Size	Q (m³/h)	L _{WA} [dB(A)]	ΔP _t (Pa)	X (m)
125	40	24	9	0,5
	60	32	17	0,7
	80	40	33	1,0
160	60	24	8	0,5
	90	32	15	0,7
200	120	40	29	1,0
	110	24	8	0,8
	150	32	15	1,1
250	200	40	29	1,4
	160	24	8	1,0
	220	32	15	1,3
315	290	40	27	1,8
	240	24	8	1,2
	320	32	15	1,5
355	420	40	26	2,0
	290	24	8	1,3
	380	32	14	1,7
400	510	40	24	2,2
	320	24	6	1,2
	440	32	11	1,7
500	610	40	20	2,3
	415	24	7	1,3
	570	32	13	1,8
	775	40	24	2,5



LEGEND

Q (m³/h): Air flow.
L_{WA} [dB(A)]: Sound power level.
ΔP_t (Pa): Total pressure loss.
X (m): Throw for a maximum velocity of 0.25 m/s at the occupied zone ΔT = -10 °C (cold), installed at 3 m of height.

DFRE-C-PR



Catalogue Series 40.3

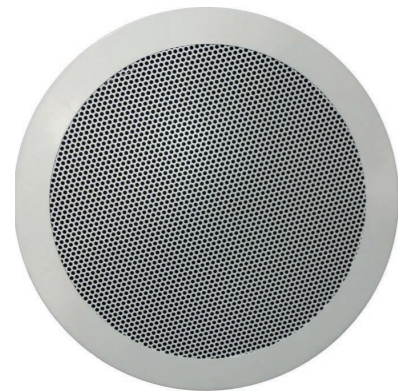

Stationary-fin swirl diffuser with perforated plate

Product description

Stationary-fin swirl diffuser with perforated plate, KOOLAIR **DFRE-C-PR** model, size $_$, dimension $_$. Consists of a perforated round plate with a stationary-fin swirl diffuser in the interior. Both the perforated plate and the swirl diffuser are removable. Manufactured entirely of steel plate. Painted RAL finish upon request. Recommended installation height of 2.5 to 3.5 m.



Other models

DFRE-C-PR-R. Circular return stationary-fin swirl diffuser with perforated plate.
DFRE-C-PR-I Coanda plate. Circular stationary-fin swirl diffuser with perforated plate and exterior extension.

Mounting

SP. Without plenum.
PCDL-RE. Lateral connection plenum box, detachable and not internally insulated, with volume control damper accessible from drop ceiling.
PCDL-A-RE. Lateral connection plenum box, detachable and internally insulated, with volume control damper accessible from drop ceiling.

Note: On request, top plenum available insulated/ uninsulated (PCDS-A-RE/PCDS-RE).

DFRE-C-PR-I Coanda plate

General dimensions

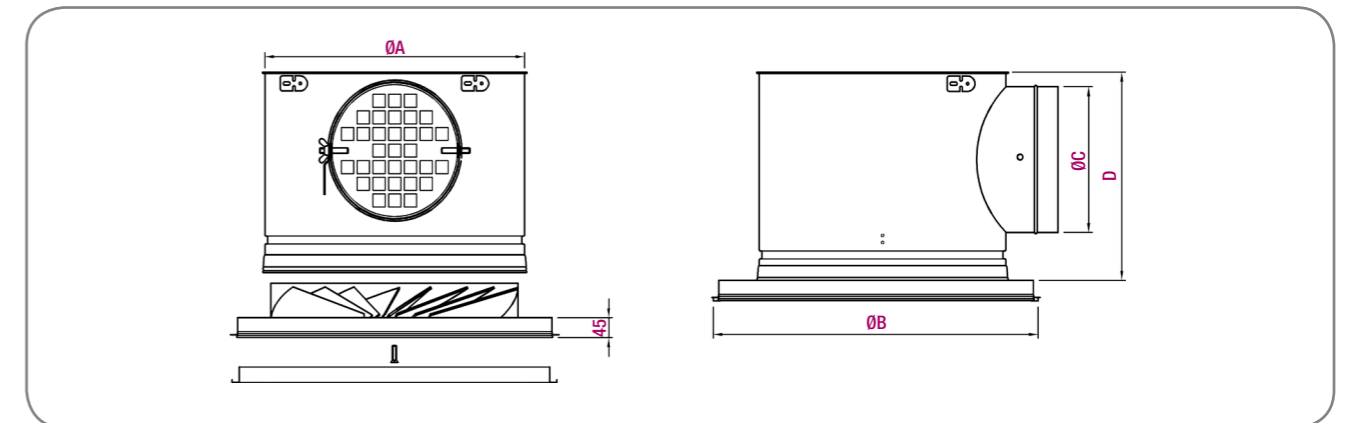

Custom plenums available to suit reduced heights above false ceilings.

Model	ØA	ØB	ØC	D	OPENING
160	173	360	124	195	335
200	213	403	159	230	337
250	263	450	199	270	423
315	328	503	249	320	475
355	368	550	249	320	523
400	413	594	314	385	567
500	513	633	315	385	605

Unit mm

Selection table

Size	Q (m³/h)	L _{WA} [dB(A)]	ΔP _t (Pa)	X (m)
160	70	24	8	0,4
	100	32	16	0,6
	140	40	31	0,8
200	110	24	9	0,5
	160	32	19	0,7
	225	40	38	1,0
250	160	24	8	0,7
	230	32	16	0,9
	330	40	34	1,3
315	250	24	5	0,8
	350	32	10	1,2
	500	40	21	1,7
355	275	24	5	0,9
	400	32	11	1,3
	545	40	23	1,9
400	475	24	8	1,3
	675	32	17	1,9
	950	40	33	2,6
500	650	24	10	1,6
	950	32	21	2,4
	1350	40	43	3,2



LEGEND

Q (m³/h): Air flow.
L_{WA} [dB(A)]: Sound power level.
ΔP_t (Pa): Total pressure loss.
X (m): Throw for a maximum velocity of 0.25 m/s at the occupied zone ΔT = -10 °C (cold), installed at 3 m of height.

HDPR



Catalogue Series 40.3

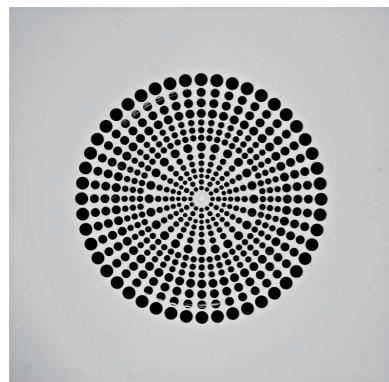

Swirl diffuser

Product description

Fixed blade swirl diffuser, KOOLAIR, model **HDPR**, size $_$, incorporated in punched sheet metal of dimensions $_x_$ mm. Incorporates side connection plenum box and volume control damper. Made in steel sheet. Finished in any RAL colour upon request. Recommended installation height between 2.5 and 3.5 m.

Other models

- HDPR-Q.** Fixed blade swirl diffuser integrated in plate of 595x595 mm, to be installed in false ceiling.
- HDPR-C.** Fixed blade swirl diffuser integrated in round plate.
- HDPR-E.** Fixed blade swirl diffuser integrated in plaster ceiling.

Mounting

- PCDL-RE.** Lateral connection plenum box, detachable and not internally insulated, with volume control damper accessible from drop ceiling.
- PCDL-A-RE.** Lateral connection plenum box, detachable and internally insulated, with volume control damper accessible from drop ceiling.

Note: On request, top plenum available insulated/ uninsulated (PCDS-A-RE/PCDS-RE).



General dimensions

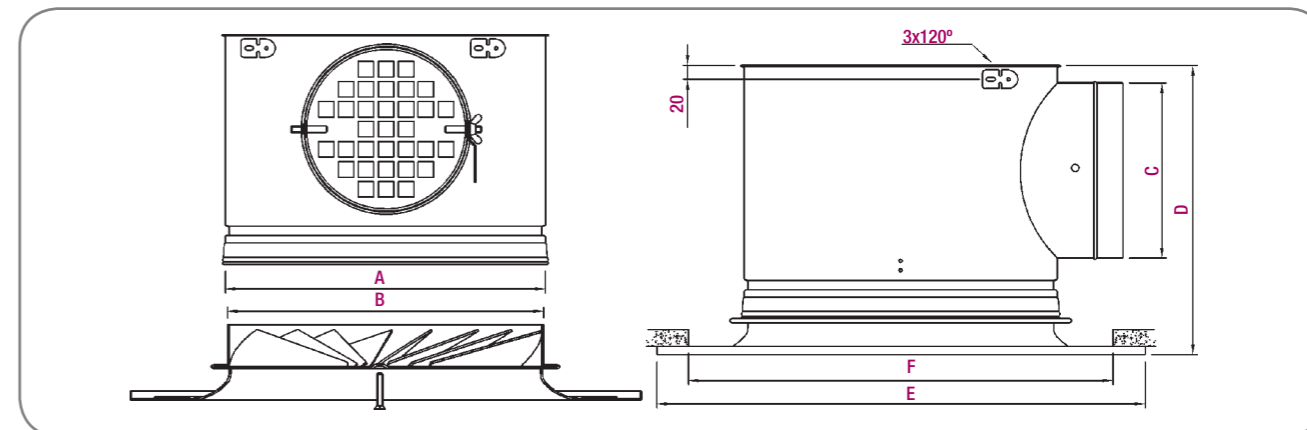

Custom plenums available to suit reduced heights above false ceilings.

HDPR

Diffuser	A	B	C	D	E	F
125	137	124	99	198	270	245
160	172	159	124	223	298	273
200	212	199	159	258	363	338
250	262	249	199	298	403	378
315	327	314	199	298	500	475
355	367	354	249	348	500	475
400	412	399	249	348	550	525

Unit mm

HDPR-Q

Diffuser	A	B	C	D
125	137	124	99	198
160	172	159	124	223
200	212	199	159	258
250	262	249	199	298
315	327	314	199	298
355	367	354	249	348
400	412	399	249	348

Unit mm

HDPR-C

Diffuser	A	B	C	D	E	F
125	137	124	99	198	270	245
160	172	159	124	223	298	273
200	212	199	159	258	363	338
250	262	249	199	298	403	378
315	327	314	199	298	500	475
355	367	354	249	348	500	475
400	412	399	249	348	550	525

Unit mm

Selection table

Size	Q (m³/h)	L _{wa} [dB(A)]	ΔP _t (Pa)	X (m)
125	45	24	8	0,5
	65	32	16	0,7
	90	40	31	0,9
160	75	24	9	0,7
	105	32	17	1,0
	140	40	30	1,4
200	110	24	7	0,7
	150	32	13	1,0
	210	40	26	1,4
250	170	24	7	0,9
	230	32	13	1,3
	310	40	24	1,8
315	260	24	7	1,2
	350	32	12	1,6
	470	40	22	2,2
355	315	24	7	1,3
	430	32	13	1,8
	580	40	24	2,4
400	350	24	6	1,2
	485	32	12	1,7
	670	40	22	2,4

LEGEND

- Q (m³/h): Air flow.
- L_{wa} [dB(A)]: Sound power level.
- ΔP_t (Pa): Total pressure loss.
- X (m): Throw for a maximum velocity of 0.25 m/s at the occupied zone ΔT = -10 °C (cold), installed at 3 m of height.

Values without plenum.

DTP



Catalogue Series DTP



DTP-C-Q

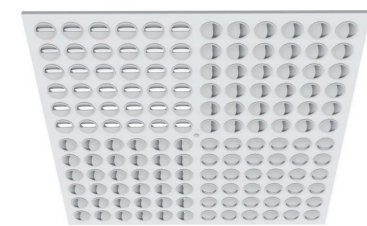

DTP-Q

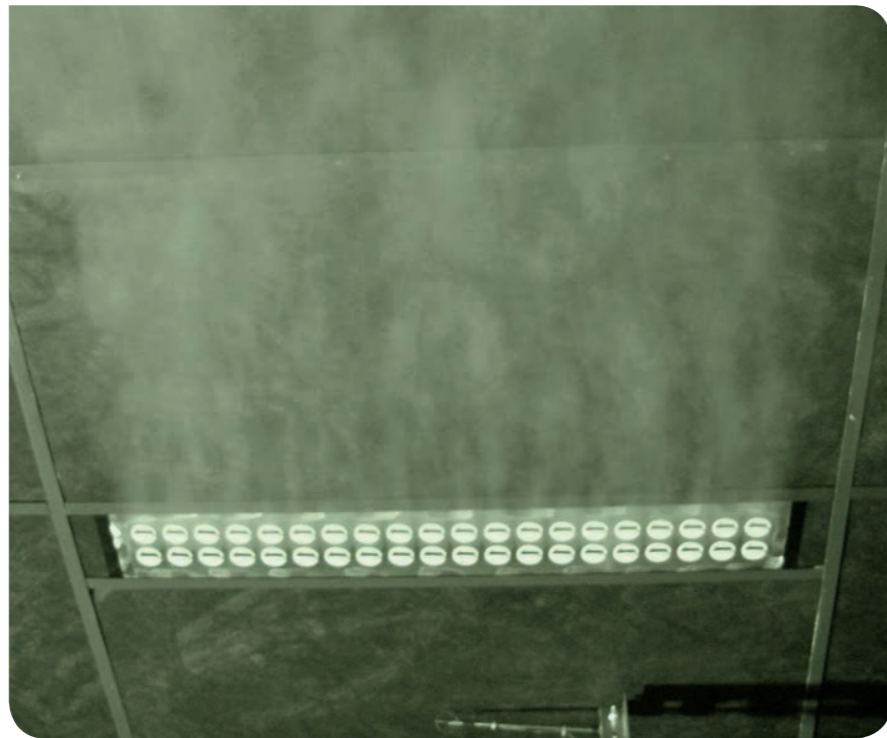

Micronozzle diffuser

Product description

Micronozzle diffuser, KOOLAIR **DTP** model, size __, plate dimensions __x__.
Composed of small nozzles, individually adjustable in all directions.
Micronozzles manufactured in white ABS-VO plastic and steel plate.
Standard finish in glossy RAL9010.

Other models

- DTP-Q.** Micronozzle diffuser built into 595x595 perforated plate for modular drop ceiling.
- DTP-C.** Micronozzle diffuser built into round plate.
- DTP-C-Q.** Micronozzle diffuser, circular layout, built into 595x595 perforated plate for modular drop ceiling.
- DTP-L.** Micronozzle diffuser, linear layout.
- DTP-PR.** Micronozzle diffuser, circular layout, built into perforated plate.

Mounting

- PDL-RE.** Plenum with side connection without insulation for square panel, with manual damper accessible from false ceiling.
- PDL-A-RE.** Plenum with side connection internally insulated for square panel, with manual damper accessible from false ceiling.

Note: On request, top plenum available insulated/ uninsulated (PCDS-A-RE/PCDS-RE).

General dimensions

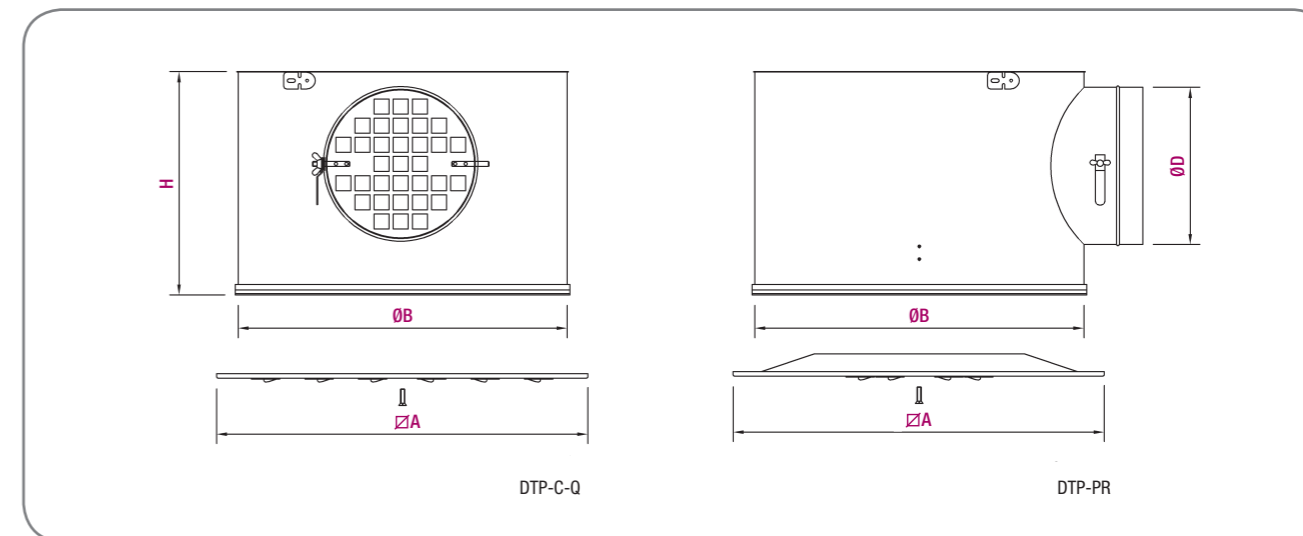

Custom plenums available to suit reduced heights above false ceilings.

Model	A	ØB	ØD	H
DTP-C-Q-16	594	580	125	200
DTP-C-Q-24			160	235
DTP-C-Q-32			200	275
DTP-C-Q-36				
DTP-C-Q-48				
DTP-C-Q-54				

Unit mm

Selection table (DTP-C-Q)

Dimension	Q (m³/h)	L _{wa} [dB(A)]	ΔP _t (Pa)	X (m)	V _k (m/s)
16	53	24	17	1.6	4.2
	70	32	29	2.1	5.5
	95	40	54	2.8	7.5
24	83	24	20	2.0	4.4
	110	32	34	2.7	5.8
	150	40	64	3.6	6.4
32	112	24	20	2.3	4.4
	150	32	35	3.1	5.9
	205	40	66	4.3	8.1
36	130	24	22	2.6	4.6
	170	32	37	3.4	6.0
	230	40	68	4.5	8.1
48	175	24	23	3.0	4.6
	220	32	36	3.8	5.8
	275	40	57	4.7	7.2
54	185	24	22	3.0	4.3
	230	32	33	3.7	5.4
	295	40	55	4.7	6.9



LEGEND

- Q (m³/h): Air flow.
- L_{wa} [dB(A)]: Sound power level.
- ΔP_t (Pa): Total pressure loss.
- X (m): Throw for a maximum velocity of 0.25 m/s at the occupied zone ΔT=0°C, installed at 3 m of height, with ceiling effect.
- V_k (m/s): Effective velocity.

DTP-GT



Catalogue Series DTP-GT

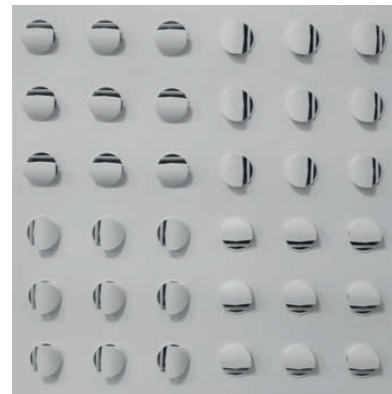

Micronozzle diffuser

Product description

Micronozzle diffuser for high flows, KOOLAIR **DTP-GT** model, size __, plate dimensions __x__. Composed of small nozzles, individually adjustable in all directions. Micronozzles manufactured in ABS-VO white plastic and steel plate. Standard finish in glossy RAL9010.

Other models

- DTP-GT-Q.** Micronozzle diffuser built into 595x595 mm plate for modular drop ceiling.
- DTP-GT-C.** Micronozzle diffuser built into round plate.
- DTP-GT-C-Q.** Micronozzle diffuser, circular layout, built into 595x595 mm plate for modular drop ceiling.
- DTP-GT-L.** Micronozzle diffuser, linear layout.
- DTP-GT-PR.** Micronozzle diffuser, circular layout, built into perforated plate.
- DTP-GT-COMBI.** Micronozzle diffuser for supplying and returning air, built into 595x595 mm.

Mounting

- PDL-RE.** Plenum with side connection without insulation for square panel, with manual damper accessible from false ceiling.
- PDL-A-RE.** Plenum with side connection internally insulated for square panel, with manual damper accessible from false ceiling.

Note: On request, top plenum available insulated/ uninsulated (PDS-A-RE/PDS-RE).

General dimensions (DTP-GT-Q)

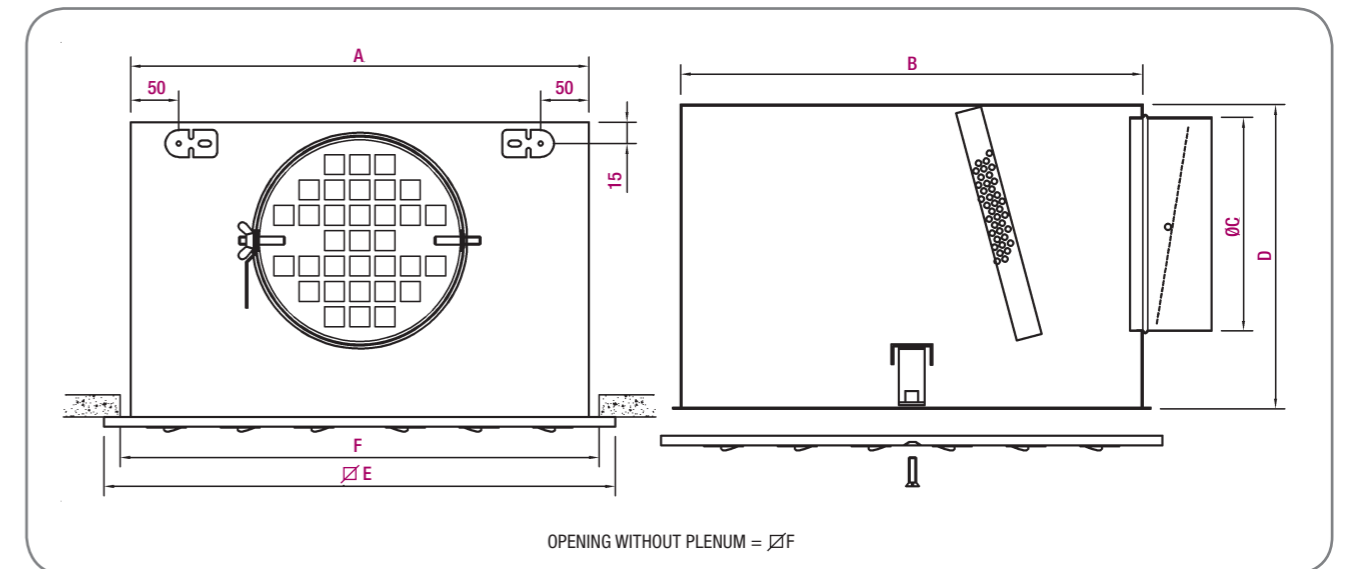

Custom plenums available to suit reduced heights above false ceilings.

Model	A	B	C	D	E	F
DTP-GT-Q-16	288	270	125	225	594	570
DTP-GT-Q-24	368	350	125	225	594	570
DTP-GT-Q-36	428	410	160	250	594	570
DTP-GT-Q-48	506	488	200	300	594	570
DTP-GT-Q-64	568	550	200	300	594	570
DTP-GT-16	288	270	125	225	294	290
DTP-GT-24	368	350	125	225	444	370
DTP-GT-36	428	410	160	250	494	430
DTP-GT-48	506	488	200	300	554	508
DTP-GT-64	568	550	200	300	594	570

Unit mm

Selection table (DTP-GT-Q 2 directions)

Dimension	Q (m³/h)	L _{wa} [dB(A)]	ΔP _t (Pa)	X (m)	V _k (m/s)
16	145	24	7	2,7	2,5
	200	32	12	3,7	3,4
	277	40	24	5,1	4,7
24	168	24	9	2,5	1,9
	233	32	17	3,5	2,6
	321	40	32	4,8	3,6
36	195	24	4	2,4	1,5
	270	32	8	3,3	2
	373	40	16	4,5	2,8
48	217	24	2	2,3	1,2
	300	32	4	3,2	1,7
	415	40	8	4,4	2,4
64	241	24	3	2,2	1
	333	32	5	3	1,4
	460	40	10	4,2	2

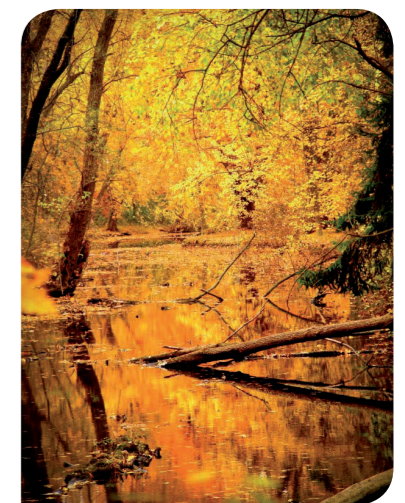

LEGEND

- Q (m³/h): Air flow.
- L_{wa} [dB(A)]: Sound power level.
- ΔP_t (Pa): Total pressure loss.
- X (m): Throw for a maximum velocity of 0.25 m/s at the occupied zone ΔT=0°C, installed at 3 m of height, with ceiling effect.
- V_k (m/s): Effective velocity.



Long throw diffusers



BMW plant
(Swindon - United Kingdom)
Long-throw nozzle DF-49.

DF-47



Catalogue Series DF-47



Long-throw rectangular diffuser

Product description

Rectangular, long-throw diffuser KOOLAIR, model **DF-47**, dimension of $_x_$. It can incorporate volume control damper (-O). The diffuser can be manually adjusted to be vertically positioned at an angle of ($\pm 20^\circ$). The unit is equipped with deflecting blades for distributing the air in horizontal fan-shape or concentrating the inlet airflow in the desired direction.

Finished in anodised aluminium or any RAL colour upon request. Recommended installation height between 2.5 and 6 m.

Mounting

With screws (-T). Without indication the diffuser is always screw-mounted.

MM. Mounting frame (-MM). Fixed with screws.

PAC. Integrated in plenum box with connection to round duct.

Other models

DF-47-TR. Rectangular long-throw diffuser autoregulated by thermal element.

DF-47-CC. Rectangular long-throw diffuser adaptable to round duct.

DF-47-CC-TR. Rectangular long-throw diffuser adaptable to round duct autoregulated by thermal element.

DF-47-MT. Rectangular long-throw diffuser with motorised mechanism.

DF-47-CC-MT. Rectangular long-throw diffuser adaptable to round duct with motorised mechanism.

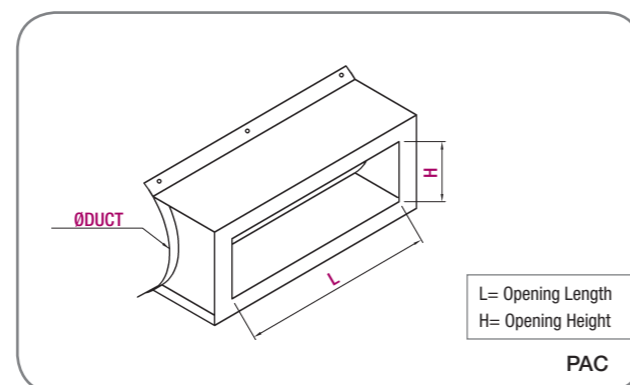

General dimensions

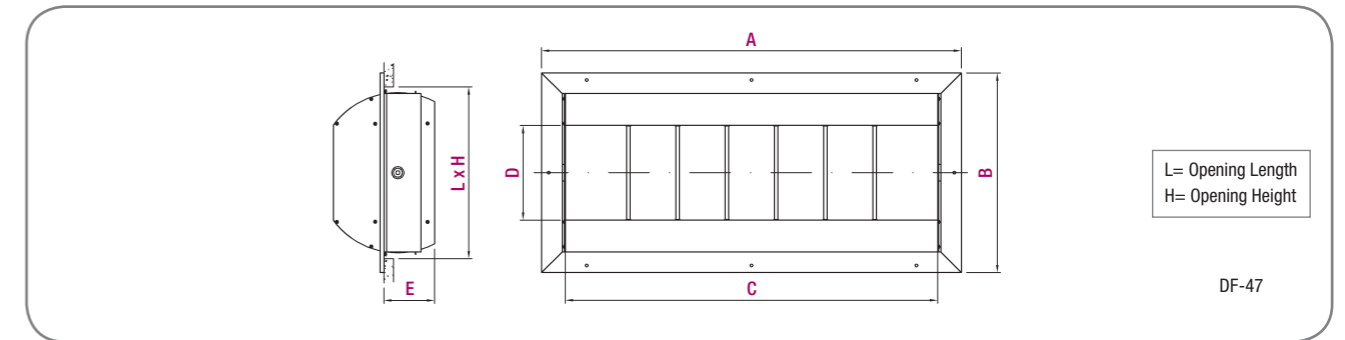

L x H	A	B	C	D	E
305 x 165	348	210	284	82	58,5
610 x 165	652	210	588	82	58,5
610 x 267	652	310	588	147	78,5
1219 x 267	1262	310	1198	147	78,5
1067 x 380	1110	422	1046	229	102

Unit mm

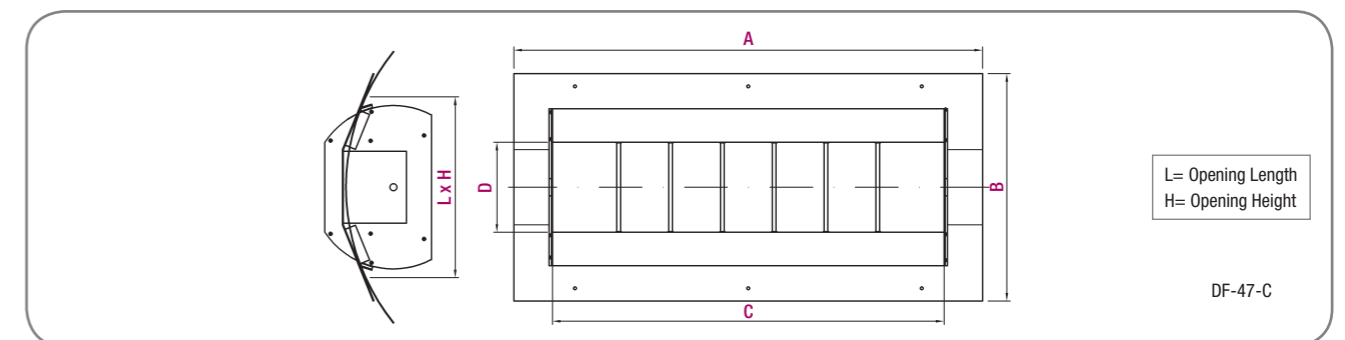

L x H	A	B	C	D
334 x 165	367	215	274	82
637 x 165	671	215	578	82
637 x 267	673	304	578	147
1247 x 267	1283	304	1188	147
1090 x 390	1171	472	1036	229

Unit mm

Selection table

Size	Dimension	Q (m³/h)	L _{WA} [dB(A)]	ΔP _t (Pa)	X _{0,3}	X _{0,5}	X _{1,0}	V _k
23	305 x 165	530	32	33	16,1	9,7	4,8	7,5
		690	40	55	21,0	12,6	6,3	9,7
		880	48	90	26,8	16,1	8,0	12,4
26	610 x 165	930	32	26	20,3	12,2	6,1	6,7
		1200	40	44	26,2	15,7	7,9	8,7
		1550	48	48	>30	20,3	10,2	11,2
36	610 x 267	1390	32	23	20,2	12,1	6,1	6,3
		1790	40	38	26,0	15,6	7,8	8,1
		2310	48	64	>30	20,1	10,1	10,5
312	1219 x 267	2490	32	19	25,7	15,4	7,7	5,7
		3210	40	31	>30	19,9	9,9	7,4
		4140	48	52	>30	25,6	12,8	9,5
410	1067 x 380	2990	32	18	22,4	13,4	6,7	5,5
		3860	40	29	28,9	17,3	8,7	7,1
		4980	48	49	>30	22,3	11,2	9,2

LEGEND

Q (m³/h): Air flow.
 L_{WA} [dB(A)]: Sound power level.
 ΔP_t (Pa): Total pressure loss.
 X_{0,3}-X_{0,5}-X_{1,0} (m): Throw for terminal velocity of the air stream of 0.3, 0.5, and 1.0 m/s, respectively, in isothermal conditions (ΔT = 0° C).
 V_k (m/s): Effective velocity.

DF-47-NARROW



Cat. DF-47-NARROW

High-induction linear diffuser for medium-to-long throw



Product description

High-induction linear diffuser for medium-to-long throw, Koolair **DF-47-NARROW** model, with length ___ mm and slot ___ mm for air passage.

Allows $\pm 30^\circ$ vertical core rotation (linear nozzle). Because the slot is narrow, medium-to-long throws can be covered to achieve comfortable conditions with cold and hot air supplies, while ensuring excellent aesthetics.

Suitable for both ceiling and wall installation. Manufactured entirely of extruded aluminium sections.

The unit can include a volume control damper (**RFS06**) and directional fins (**-G**). Recommended installation height of 2.5 to 6 m.

Other models

DF-47-NARROW-IC. Linear diffuser for medium-to-long throw, integrated with exposed circular duct.

DF-47-NARROW-CC. Linear diffuser for medium-to-long throw, with exposed circular duct adaption.

DF-47-NARROW-TR. Linear diffuser for medium-to-long throw, self-adjusting by thermal component. Available in **-CC** and **-IC** versions.

DF-47-NARROW-MT. Linear diffuser for medium-to-long throw, motor-driven.

Available in **-CC** and **-IC** versions.

DF-47-NARROW-I/R. Linear diffuser for medium-to-long throw, for supply/return.

Mounting

MM. With Mounting frame.

T. With screws.

PM. With mounting bridge.

RFS-06. With volume control damper RFS-06.

G. With directional fins.

PFL-RL. Fixed plenum box made in galvanised steel sheet, without insulation.

PFL-A-RL. Fixed plenum box made in galvanised steel sheet, insulated.

PDL-RL. Removable plenum box made in galvanised steel sheet, without insulation.

PDL-A-RL. Removable plenum box made in galvanised steel sheet, insulated.

Note: On request, top plenum available insulated/uninsulated (PDS-A-RE/PDS-RE).

General dimensions

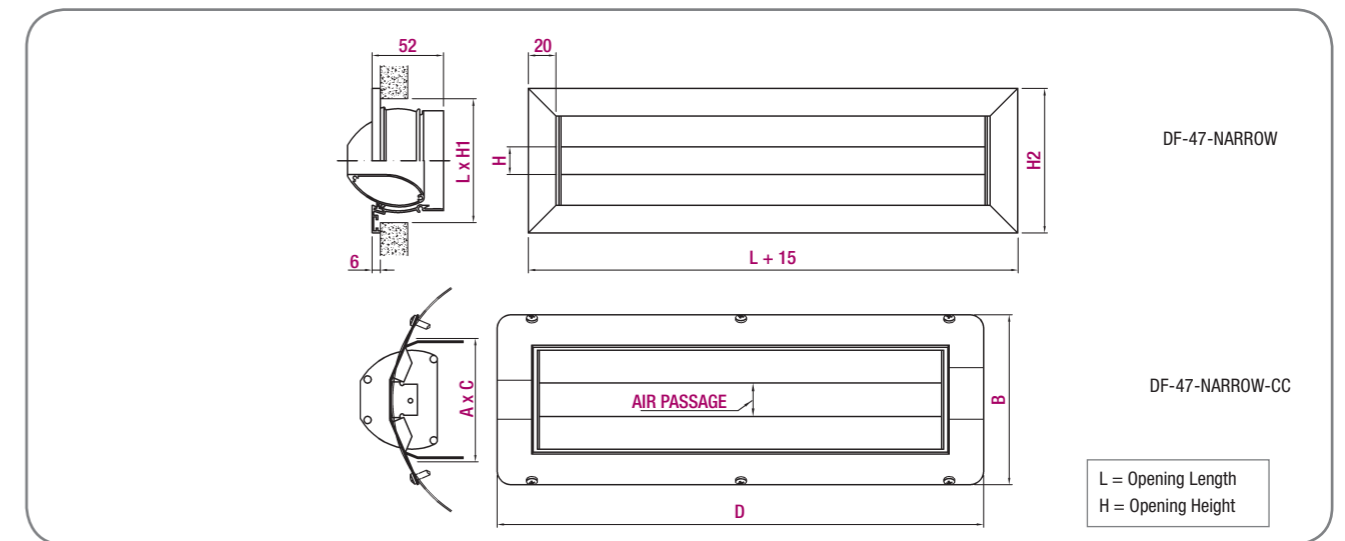

Custom plenums available to suit reduced heights above false ceilings.

DF-47-NARROW-CC

NOMINAL (Ø DUCT)	AIR PASSAGE									
	15		20		30		40		50	
	A	B	A	B	A	B	A	B	A	B
200	85	113	88	115	97	123	97	120	-	-
250	84	113	89	118	97	123	106	133	115	138
300	84	113	89	118	97	126	106	133	115	141
315	83	113	89	118	97	126	106	133	116	143
355	83	113	88	118	97	126	107	136	116	146
400	83	113	88	118	97	126	107	136	117	146
450	83	114	88	119	96	126	106	136	117	146
500	83	114	88	119	96	126	106	136	117	146
560	83	114	88	119	96	126	106	136	117	146
630	83	114	88	119	96	127	104	135	116	146
710	83	114	88	119	96	127	104	135	116	146
800	83	114	88	119	96	127	104	135	116	146
900	83	114	88	119	96	127	104	135	116	146

Unit mm

LENGTH	C	D
500	500	525
600	600	625
700	700	725
800	800	825
900	900	925
1000	1000	1025
1100	1100	1125
1200	1200	1225

Unit mm

DF-47-NARROW

H	H1	H2
15	85	100
20	90	105
30	100	115
40	110	125
50	120	135

Unit mm

Selection table

(Flow rate per linear metre of diffuser)

Size	Dimension	Q (m³/h)	L _{wa} [dB(A)]	ΔP _t (Pa)	X _{0,3}	X _{0,5}	X _{1,0}	V _k (m/s)
15	1000	280	24	20	8,3	5,0	2,5	7,2
		450	32	51	13,4	8,0	4,0	11,6
		700	40	124	20,8	12,5	6,2	18,0
20	1000	400	24	21	10,3	6,2	3,1	7,7
		570	32	43	14,7	8,8	4,4	11,0
		800	40	85	20,7	12,4	6,2	15,5
30	1000	485	24	14	9,0	5,4	2,7	4,8
		675	32	27	12,5	7,5	3,8	6,7
		925	40	51	17,1	10,3	5,1	9,2
40	1000	600	24	12	9,6	5,8	2,9	4,5
		825	32	22	13,2	7,9	4,0	6,1
		1150	40	43	18,4	11,0	5,5	8,5
50	1000	625	24	8	8,9	5,4	2,7	3,7
		925	32	19	13,2	7,9	4,0	5,5
		1350	40	40	19,3	11,6	5,8	8,0

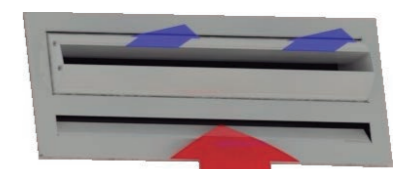

DF-47-Narrow - I/R

LEGEND

- Q (m³/h): Air flow.
- L_{wa} [dB(A)]: Sound power level.
- ΔP_t (Pa): Total pressure loss.
- X_{0,3}-X_{0,5}-X_{1,0} (m): Throw for terminal velocity of the air stream of 0.3, 0.5, and 1.0 m/s, respectively, in isothermal conditions (ΔT = 0° C).
- V_k (m/s): Effective velocity.

DF-47-NARROW-LT Cat. DF-47-NARROW



Hidden high induction linear diffuser for medium-long throw

Product description

Invisible high induction linear diffuser for medium-long throw, Koolair **DF-47-NARROW-LT** model, with length ___ mm and slot ___ mm for air passage. Characterised by the lack of profile on show. Because the slot is narrow, medium-to-long throws can be covered to achieve comfortable conditions with cold and hot air supplies, while ensuring excellent aesthetics.

Suitable for both ceiling and wall installation. Made with aluminium profiles, all painted in RAL 9005.

The unit can include a volume control damper (**RFS06**) and directional fins (**-G**).

For installation heights over 3.5 m in ceilings and between 2.5 m and 3.5 m on walls.

Note: Possible to form continuous lines (Maximum length per section 2000 mm).

On request, top plenum available insulated/uninsulated (PFS-A-RL/PFS-RL).

Other models

DF-47-NARROW-LT-D. Decorative invisible linear slot diffuser devised to form a continuous line with other active or decorative sections

CROSS-DF-47-NARROW-LT. Decorative invisible linear slot diffuser in the shape of a cross at 90° devised to form a continuous line with other active or decorative sections.

T-DF-47-NARROW-LT. Decorative invisible linear diffuser in the shape of a "T" at 90° devised to form a continuous line with other active or decorative sections.

MITRED-CORNER-DF-47-NARROW-LT.

Decorative invisible linear slot diffuser in the shape of an elbow at 90° devised to form a continuous line with other active or decorative sections.

Mounting

PFL-RL. Fixed plenum box made in galvanised steel sheet, without insulation.

PFL-A-RL. Fixed plenum box made in galvanised steel sheet, insulated.

General dimensions

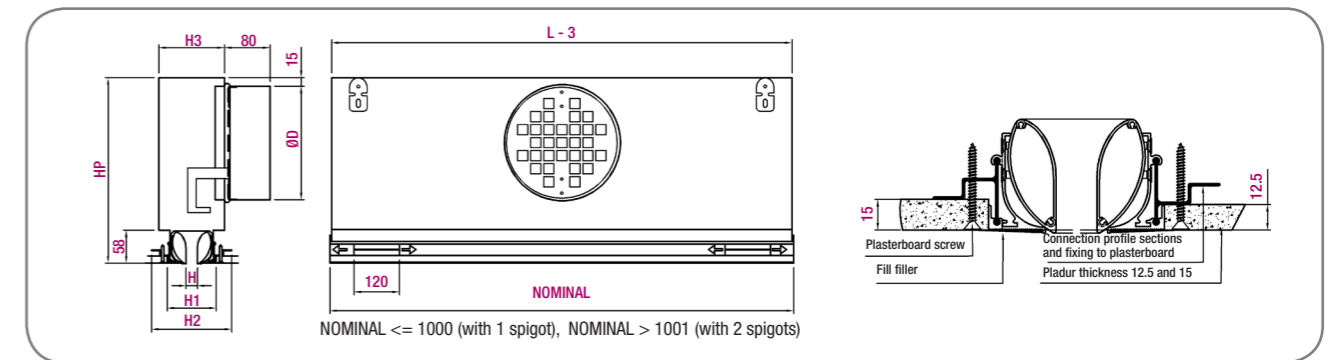

Custom plenums available to suit reduced heights above false ceilings.

H	H1	H2	H3	ØD	HP
15	81	136	110	Ø159	285
20	86	141	115	Ø199	325
30	96	151	125	Ø249	375
40	106	161	190	Ø314 (oval)	325
50	116	171	190	Ø314 (oval)	325

H = Slot width

Unit mm

Selection table (Horizontal supply, from wall)

H	Dimension	Q (m³/h)	L _{wa} [dB(A)]	ΔP _t (Pa)	X _{0,3}	X _{0,5}	X _{1,0}	V _k (m/s)
15	1000	280	24	20	8,3	5,0	2,5	7,2
		450	32	51	13,4	8,0	4,0	11,6
		700	40	124	20,8	12,5	6,2	18,0
20	1000	400	24	21	10,3	6,2	3,1	7,7
		570	32	43	14,7	8,8	4,4	11,0
		800	40	85	20,7	12,4	6,2	15,5
30	1000	485	24	14	9,0	5,4	2,7	4,8
		675	32	27	12,5	7,5	3,8	6,7
		925	40	51	17,1	10,3	5,1	9,2
40	1000	600	24	12	9,6	5,8	2,9	4,5
		825	32	22	13,2	7,9	4,0	6,1
		1150	40	43	18,4	11,0	5,5	8,5
50	1000	625	24	8	8,9	5,4	2,7	3,7
		925	32	19	13,2	7,9	4,0	5,5
		1350	40	40	19,3	11,6	5,8	8,0

Selection table (Vertical supply, from ceiling)

H	Dimension	Q (m³/h)	L _{wa} [dB(A)]	ΔP _t (Pa)	Y _{max}	V _k (m/s)
15	1000	220	20	12	4,3	5,6
		280	24	20	5,4	7,2
		350	28	31	6,8	9,0
20	1000	330	20	14	5,2	6,4
		390	24	20	6,1	7,5
		470	28	29	7,4	9,1
30	1000	420	20	10	4,0	4,2
		490	24	14	4,7	4,9
		575	28	20	5,5	5,7
40	1000	500	20	8	3,9	3,7
		590	24	11	4,5	4,4
		700	28	16	5,4	5,2
50	1000	530	20	6	3,5	3,15
		630	24	9	4,1	3,7
		765	28	13	5,0	4,5

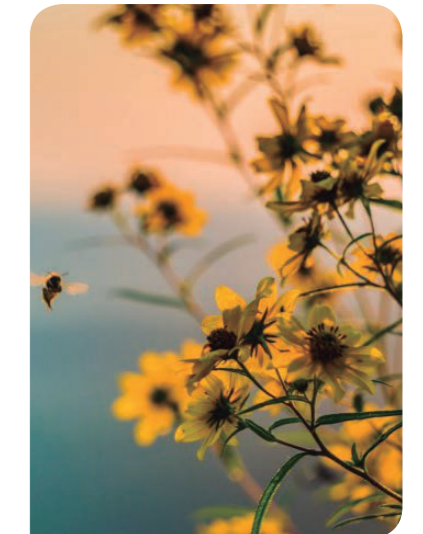

LEGEND

- Q (m³/h): Air flow.
- L_{wa} [dB(A)]: Sound power level.
- ΔP_t (Pa): Total pressure loss.
- X (m): Throw for terminal velocity of the air stream of 0.3, 0.5, and 1.0 m/s, respectively, in isothermal conditions (ΔT = 0° C).
- V_k (m/s): Effective velocity.
- Y_{max} (m): Maximum vertical penetration at ΔT = +10 °C (heating).

The Selection Table shows a summary of dimensions. Other sizes available. Consult the Sales Department.

DF-48



Catalogue Series DF-48



Long throw spherical diffuser

Product description

Long-throw spherical diffuser, KOOLAIR, model **DF-48**, size $_$. The configuration allows the diffuser to be swiveled in any direction up to a maximum of ($\pm 35^\circ$) in the horizontal or vertical direction. It has a volume control damper at the outlet. Made in aluminium. Finished in anodised aluminium or painted in any RAL colour upon request.

Other models

DF-48-B. Spherical long-throw diffuser, with direct coupling collar to flexible duct. With screws. Without indication the diffuser is always screw-mounted.

Mounting

With screws (-T). Without indication the diffuser is always screw-mounted.

AM. With metal mounting ring.

AC. Integrated in flat plate for connection to round duct. Depending on the size, 6 is the maximum number of diffusers, (to be consulted).

PAC. Integrated in plenum box with connection to round duct. Depending on the size, 6 is the maximum number of diffusers, (to be consulted).

PLC. Integrated in plate with 45° full saddle tap for lateral connection to round duct. Depending on the size, 6 is the maximum number of diffusers, (to be consulted).

INJ. 45° full saddle tap for lateral connection to exposed circular duct. One adapter per diffuser.

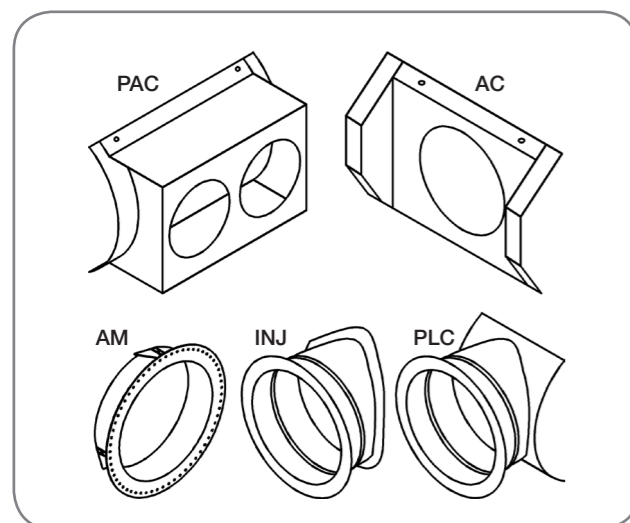

General dimensions

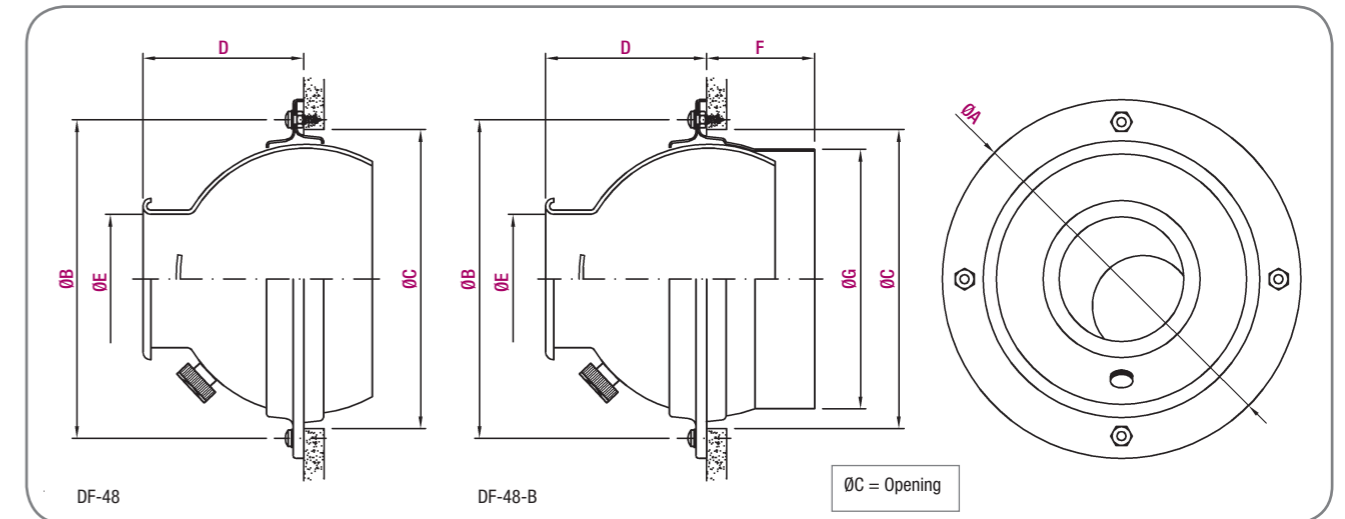

Model	Ø A	Ø B	Ø C	D	Ø E	F	Ø G
3	132	107	80	44	40	26	61
5	205	182	143	91	65	48	123
8	276	254	215	129	100	50	198
10	324	301	265	150	136	79	248
12	380	356	322	201	165	74	313
16	495	470	425	249	230	113	398
20	553	533	500	296	300	135	498

Unit mm

Selection table

Size	Q (m³/h)	L _{WA} [dB(A)]	ΔP _t (Pa)	X _{0,3}	X _{0,5}	X _{1,0}	V _k
3	60	32	109	8.4	5.0	2.5	12.8
	80	40	175	6.7	4.0	2.0	17.1
	110	48	331	14.7	8.8	4.4	23.5
5	140	32	82	11.7	7.0	3.5	11.8
	180	40	138	15.1	9.1	4.5	15.2
	240	48	245	20.1	12.1	6.0	20.2
8	290	32	64	15.9	9.6	4.8	10.2
	380	40	107	20.6	12.4	6.2	13.4
	500	48	185	27.1	16.3	8.1	17.6
10	460	32	46	18.4	11.0	5.5	8.8
	650	40	91	26.0	15.6	7.8	12.4
	910	48	179	>30	21.8	10.9	17.4
12	690	32	48	22.7	13.6	6.8	9.0
	900	40	82	29.6	17.8	8.9	11.7
	1170	48	138	>30	23.1	11.6	15.2
16	1220	32	40	28.8	17.3	8.7	8.2
	1590	40	68	>30	22.5	11.3	10.6
	2060	48	114	>30	29.2	14.6	13.8
20	1930	32	35	>30	21.0	10.5	7.6
	2500	40	58	>30	27.2	13.6	9.8
	3260	48	98	>30	>30	17.7	12.8

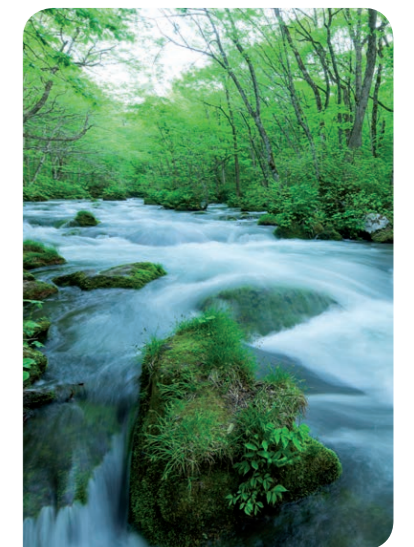

LEGEND

Q (m³/h): Air flow.
 L_{WA} [dB(A)]: Sound power level.
 ΔP_t (Pa): Total pressure loss.
 X_{0,3}-X_{0,5}-X_{1,0} (m): Throw for terminal velocity of the air stream of 0.3, 0.5, and 1.0 m/s, respectively, in isothermal conditions (ΔT = 0° C).
 V_k (m/s): Effective velocity.

DF-49



Catalogue Series DF-49



Long throw nozzle

Product description

Long-throw nozzle, KOOLAIR, model **DF-49-A**, size $_$, used for diffusion large areas. The configuration allows the nozzle to swivel in all directions up to a maximum of ($\pm 30^\circ$). It incorporates a decorative ring, that hides the mounting screws. Made in aluminium. Painted in any RAL colour upon request.

Other models

DF-49-MT. Long-throw nozzle with motorised mechanism (sizes 8 to 16).
DF-49-B. Long-throw nozzle, allows a flexible duct of standard dimensions to be coupled directly to each nozzle.
DF-49-TR. Rectangular long-throw nozzle autoregulated by thermal element.

Mounting

With screws (-T). Without indication the diffuser is always screw-mounted.
AM. With metal mounting ring.
AC. Integrated in flat plate for connection to round duct. Depending on the size, 6 is the maximum number of diffusers, (to be consulted).
PAC. Integrated in plenum box with connection to round duct. Depending on the size, 6 is the maximum number of diffusers, (to be consulted).
PLC. Integrated in plate with 45° full saddle tap for lateral connection to round duct. Depending on the size, 6 is the maximum number of diffusers, (to be consulted).
INJ. 45° full saddle tap for lateral connection to exposed circular duct. One adapter per diffuser.
AR. Integrated in flat plate for installation in wall or square ductwork. Maximum number of diffusers according to size (see table on next page).

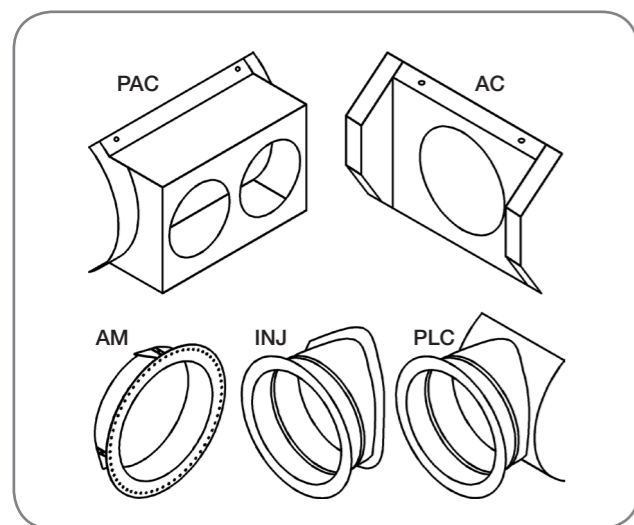

General dimensions

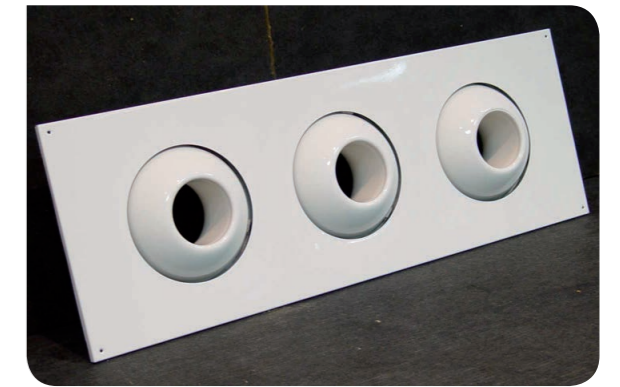
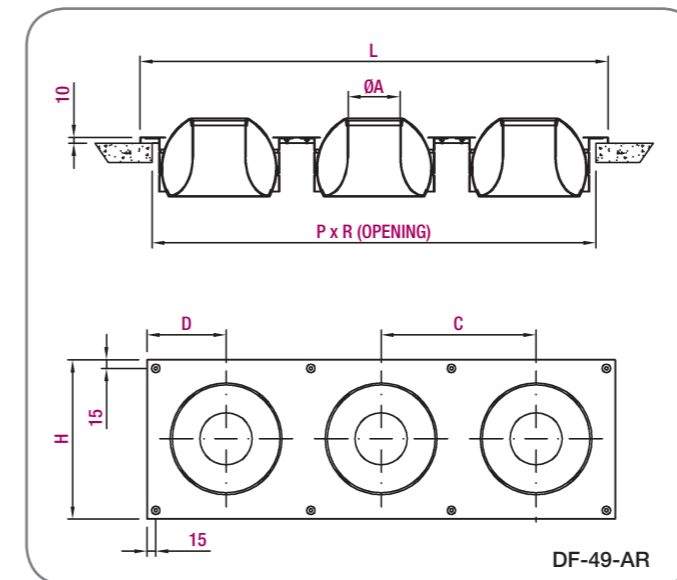

Dimensions (DF-49-AR)

	NOZZLES																		
	1		2		3		4		5		6		7		H	R	A	C	D
	L	P	L	P	L	P	L	P	L	P	L	P	L	P					
5"	225	160	450	385	675	610	900	835	1125	1060	1350	1285	1575	1510	225	160	55	225	113
8"	275	225	550	500	825	775	1100	1050	1375	1325	1650	1600	1925	1875	275	225	90	275	138
10"	350	275	700	625	1050	975	1400	1325	1750	1675					350	275	123	350	175
12"	380	325	760	705	1140	1085	1520	1465	1900	1845					380	325	155	380	190
16"	525	450	1050	975	1575	1500									525	450	220	525	263

Unit mm

Selection table

Size	Q (m³/h)	L _{WA} [dB(A)]	ΔP _t (Pa)	X _{0,3}	X _{0,5}	X _{1,0}	V _k
3	60	24	81	13	8	4	13,5
	80	32	147	18	11	5	18,1
	110	40	266	24	14	7	24,4
5	110	24	80	17	10	5	12,2
	140	32	129	21	13	6	15,5
	185	40	225	28	17	8	20,5
8	235	24	61	22	13	6	10,8
	305	32	103	28	17	8	14,1
	400	40	175	37	22	11	18,4
10	480	32	69	>30	18	9	10,6
	610	40	112	>30	23	12	13,4
	780	48	183	>30	>30	15	17,2
12	820	32	76	>30	26	13	12,4
	1070	40	130	>30	>30	17	16,1
	1400	48	222	>30	29	15	21,1
16	1360	32	48	>30	28	14	9,7
	1770	40	81	>30	>30	24	12,6
	2300	48	136	>30	>30	24	16,4
20	2500	32	35	>30	>30	19,1	9,6
	3300	40	61	>30	>30	25,2	12,7
	4250	48	102	>30	>30	>30	16,3

LEGEND

Q (m³/h): Air flow.
L_{WA} [dB(A)]: Sound power level.
ΔP_t (Pa): Total pressure loss.
X_{0,3}-X_{0,5}-X_{1,0} (m): Throw for terminal velocity of the air stream of 0.3, 0.5, and 1.0 m/s, respectively, in isothermal conditions (ΔT = 0° C).
V_k (m/s): Effective velocity.

DF-49

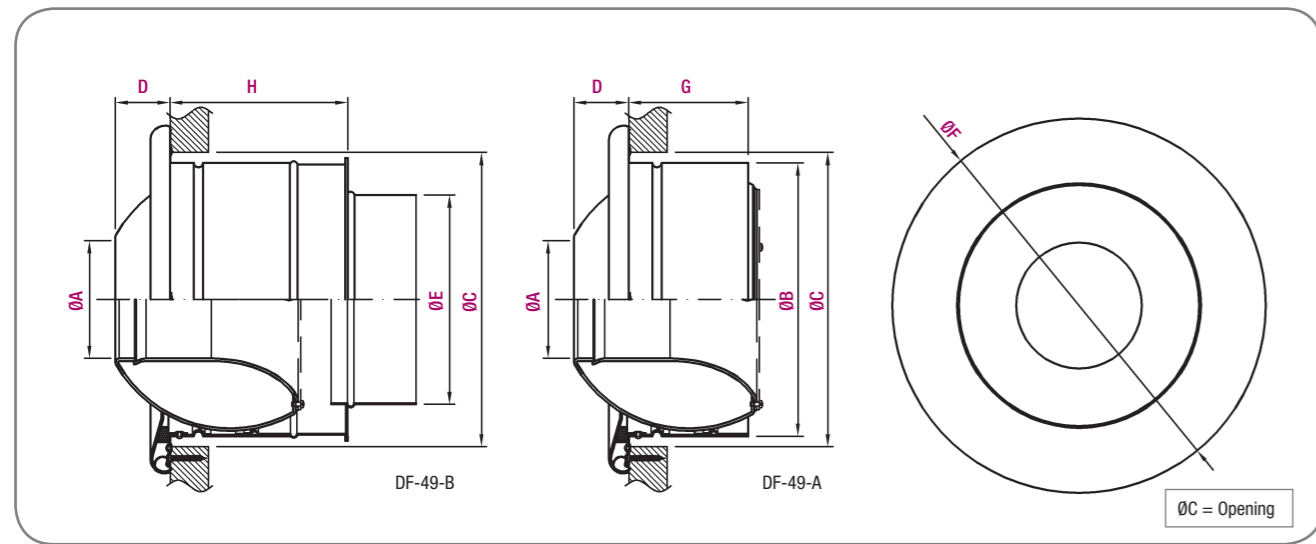

Dimensions (DF-49)

Model/Diffuser	Ø A	Ø B	Ø C	D	Ø E	Ø F	G	H
5	55	135	155	21	99	209	63	106
8	90	208	225	34	159	268	100	144
10	123	257	275	48	199	317	132	202
12	155	314	330	56	249	376	132	224
16	220	417	440	78	399	511	156	236
20	290	493	510	100	399	584	173	265

Unit mm

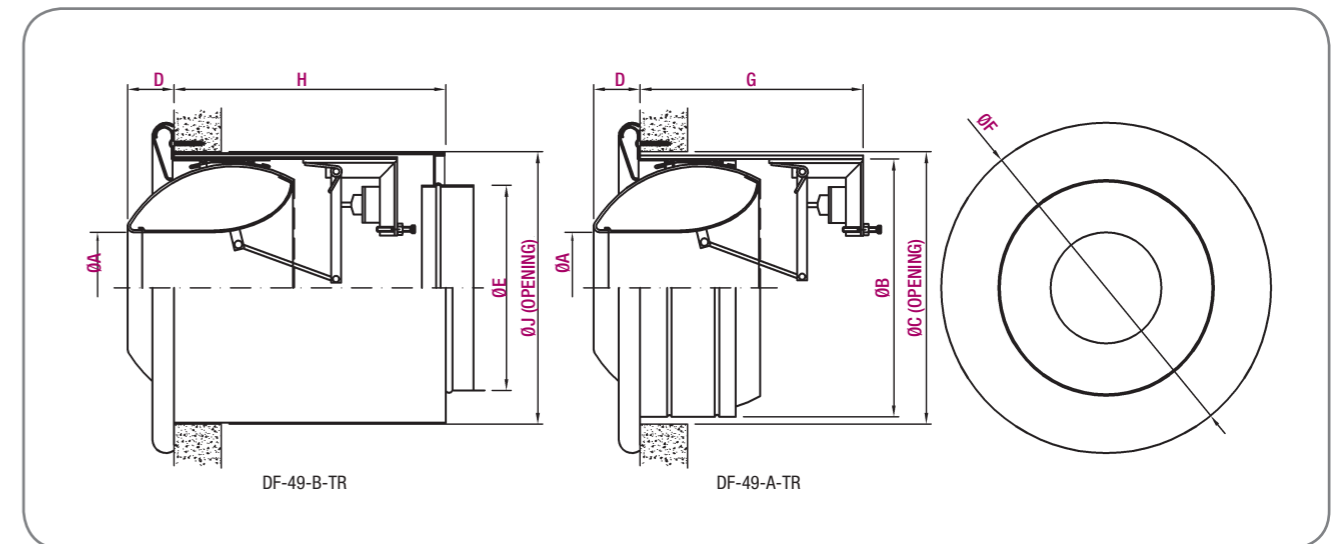

Dimensions (DF-49-TR)

Model/Diffuser	Ø A	Ø B	Ø C	D	Ø E	Ø F	G	H	Ø J
5	55	145	160	28	99	210	151	210	173
8	90	215	230	39	159	268	179	240	236
10	123	264	282	48	199	317	202	263	286
12	155	318	335	53	249	376	241	300	341
16	220	425	445	88	399	511	300	360	476

Unit mm

Dimension DF-49-3

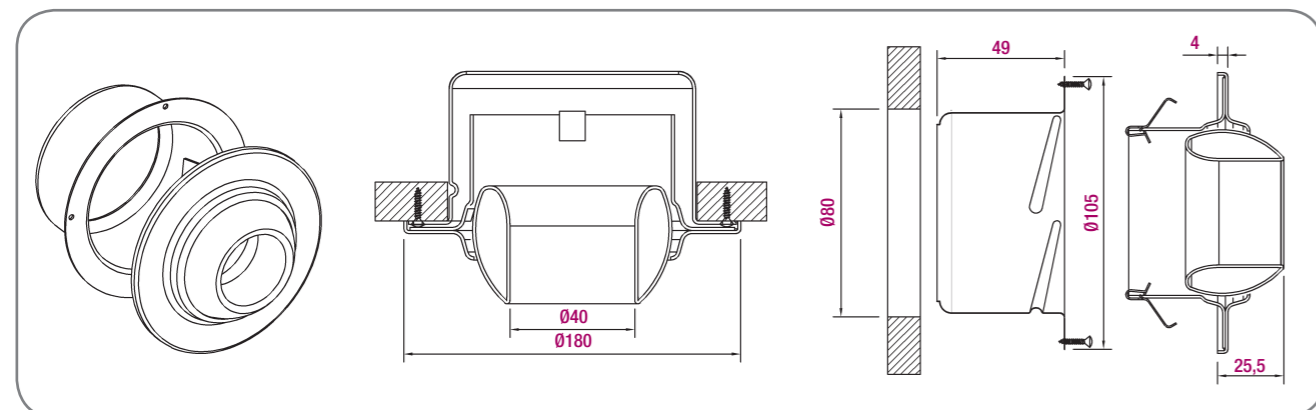

DF-49-ROT



Catalogue Series DF-49-ROT



Long throw nozzle

Product description

Long-throw nozzle with swirl element, KOOLAIR, model **DF-49-A-ROT**, size __, used for diffusion large areas for small jet penetration. The configuration allows the nozzle to swivel in all directions up to a maximum of ($\pm 30^\circ$) for the orientation of the air jet. It incorporates a decorative ring, that hides the mounting screws. Made in aluminium. Painted in any RAL colour upon request.

Other models

DF-49-B-ROT. Long-throw nozzle, with swirl element, allows a flexible duct of standard dimensions to be coupled directly to each nozzle.
DF-49-ROT-TR. Rectangular long-throw nozzle, with swirl element, autoregulated by thermal element. Available up to size 16.

Mounting

With screws (-T). Without indication the diffuser is always screw-mounted.
AM. With metal mounting ring.
AC. Integrated in flat plate for connection to round duct. Depending on the size, 6 is the maximum number of diffusers, (to be consulted).
PAC. Integrated in plenum box with connection to round duct. Depending on the size, 6 is the maximum number of diffusers, (to be consulted).
PLC. Integrated in plate with 45° full saddle tap for lateral connection to round duct.. Depending on the size, 6 is the maximum number of diffusers, (to be consulted).
INJ. 45° full saddle tap for lateral connection to exposed circular duct. One adapter per diffuser.

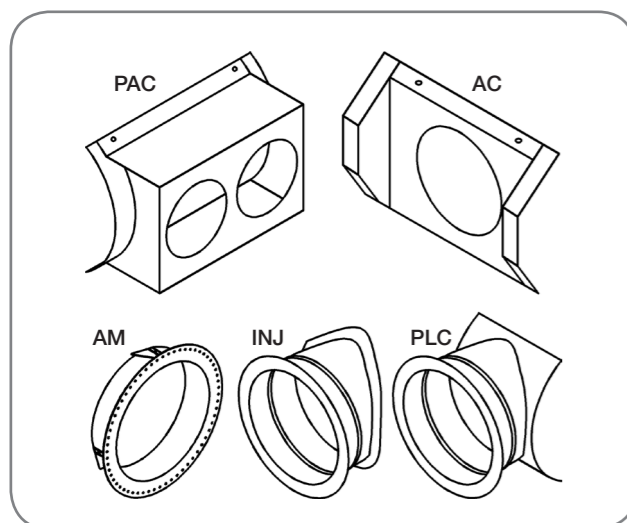

General dimensions

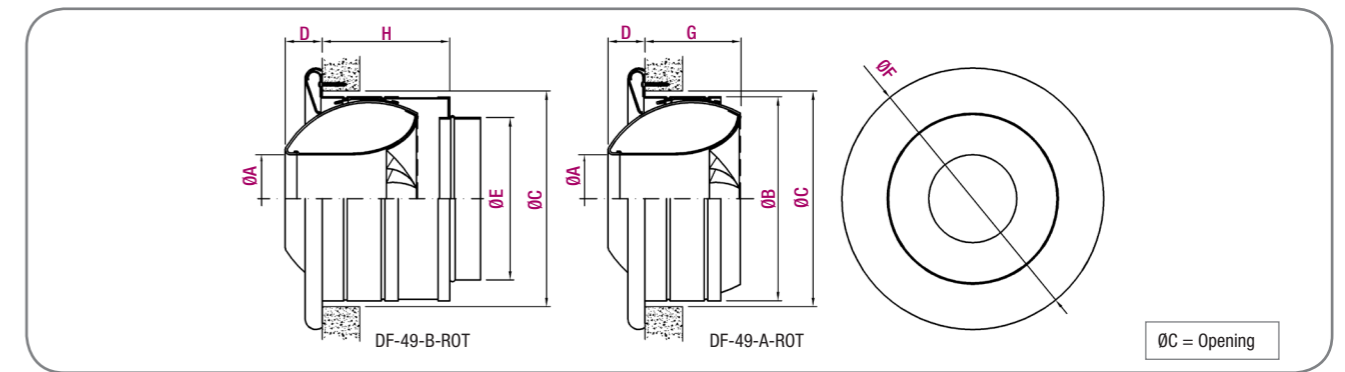

Dimensions (DF-49-ROT)

Model	Ø A	Ø B	Ø C	D	Ø E	Ø F	H	G
8	90	208	217	34	159	268	144	100
10	123	257	268	48	199	317	202	132
12	155	314	323	56	249	376	224	132
16	220	417	433	78	399	511	236	156
20	290	493	510	100	399	584	265	170

Unit mm

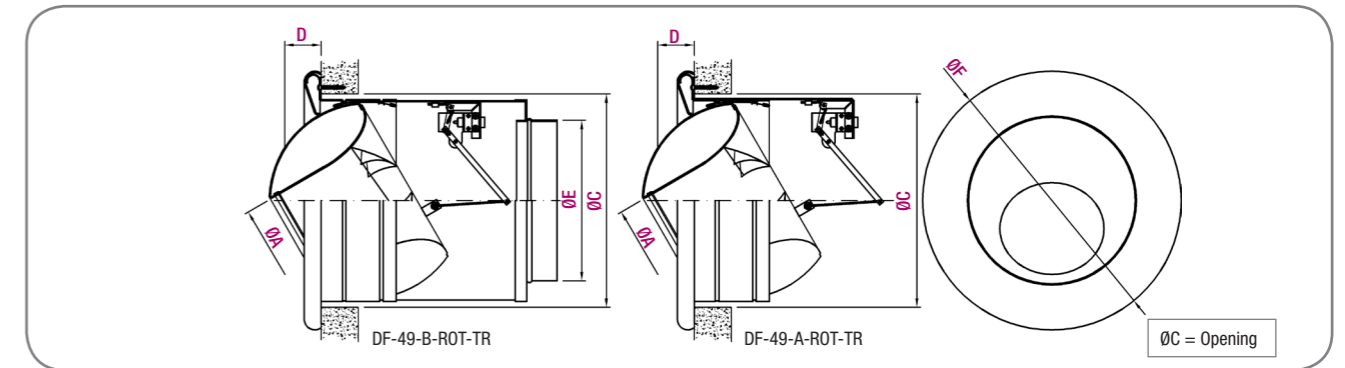

Dimensions (DF-49-ROT-TR)

Model	Ø A	Ø C	D	Ø E	Ø F
8	90	230	39	159	268
10	123	282	48	199	317
12	155	335	53	249	376
16	220	445	88	399	511

Unit mm

Selection table

Size	Q (m³/h)	L _{WA} [dB(A)]	ΔP _t (Pa)	X _{0,3}	X _{0,5}	X _{1,0}	V _k
8	220	32	60	16	10	5	10,1
	290	40	104	21	13	6	13,4
	375	48	174	28	17	8	17,3
10	360	32	44	18	11	5	7,9
	460	40	71	23	14	7	10,1
	575	48	111	29	17	9	12,7
12	600	32	45	25	15	7	9,1
	770	40	75	>30	19	10	11,6
	1000	48	126	>30	25	12	15,1
16	975	32	28	27	16	8	6,9
	1250	40	45	>30	21	10	8,9
	1650	48	79	>30	27	14	11,7
20	1800	32	20	>30	22	11	6,9
	2350	40	35	>30	29	14	9,0
	3100	48	60	>30	>30	19	11,9

LEGEND

Q (m³/h): Air flow.
L_{WA} [dB(A)]: Sound power level.
ΔP_t (Pa): Total pressure loss.
X_{0,3}-X_{0,5}-X_{1,0} (m): Throw for terminal velocity of the air stream of 0.3, 0.5, and 1.0 m/s, respectively, in isothermal conditions (ΔT = 0° C)
V_k (m/s): Effective velocity.

DF-89



Catalogue Series DF-89



Long throw nozzle

Product description

Long-throw nozzle, KOOLAIR, model **DF-89-A**, size __, used for diffusion large areas. The configuration allows the nozzle to swivel in all directions up to a maximum of ($\pm 30^\circ$), for the orientation of the air jet.

It incorporates a decorative ring, that hides the mounting screws. Made in aluminium. Painted in any RAL colour upon request.

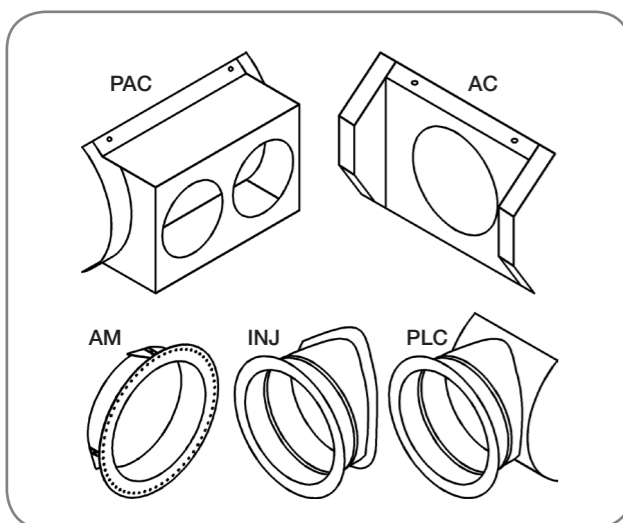

Other models

DF-89-B. Spherical long-throw diffuser, with direct coupling collar to flexible duct.

Mounting

With screws (-T). Without indication the diffuser is always screw-mounted.

AM. With metal mounting ring.

AC. Integrated in flat plate for connection to round duct. Depending on the size, 6 is the maximum number of diffusers, (to be consulted).

PAC. Integrated in plenum box with connection to round duct. Depending on the size, 6 is the maximum number of diffusers, (to be consulted).

PLC. Integrated in plate with 45 ° full saddle tap for lateral connection to round duct.. Depending on the size, 6 is the maximum number of diffusers, (to be consulted).

INJ. 45° full saddle tap for lateral connection to exposed circular duct. One adapter per diffuser.

General dimensions

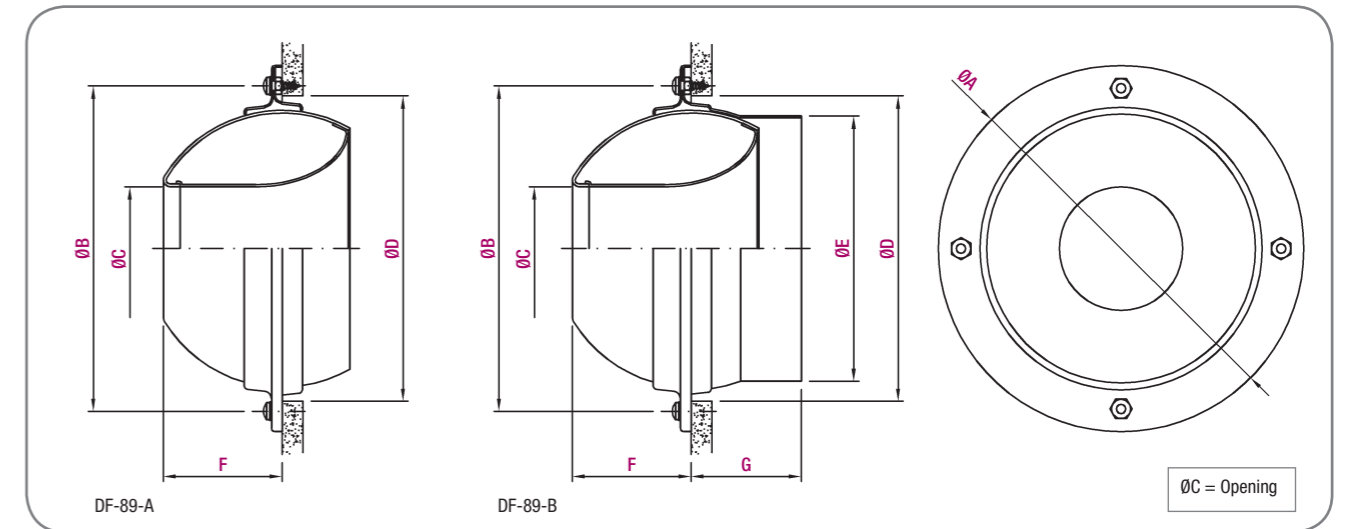

Model/diffuser	Ø A	Ø B	Ø C	Ø D	Ø E	Ø F	Ø G
5	205	182	55	143	123	68	48
8	276	254	90	215	198	80	50
10	324	301	123	265	248	105	79
12	380	356	155	322	313	132	74
16	495	470	220	425	398	170	113
20	553	533	290	506	498	185	135

Unit mm

Selection table

Size	Q (m³/h)	L _{WA} [dB(A)]	ΔP _t (Pa)	X _{0,3}	X _{0,5}	X _{1,0}	V _k
5	110	24	80	17	10	5	12,2
	140	32	129	21	13	6	15,5
	185	40	225	28	17	8	20,5
8	235	24	61	22	13	6	10,8
	305	32	103	28	17	8	14,1
	400	40	175	37	22	11	18,4
10	480	32	69	>30	18	9	10,6
	610	40	112	>30	23	12	13,4
	780	48	183	>30	>30	15	17,2
12	820	32	76	>30	26	13	12,4
	1070	40	130	>30	>30	17	16,1
	1400	48	222	>30	29	15	21,1
16	1360	32	48	>30	28	14	9,7
	1770	40	81	>30	>30	24	12,6
	2300	48	136	>30	>30	24	16,4
20	2500	32	35	>30	>30	19,1	9,6
	3300	40	61	>30	>30	25,2	12,7
	4250	48	102	>30	>30	>30	16,3



LEGEND

Q (m³/h): Air flow.
 L_{WA} [dB(A)]: Sound power level.
 ΔP_t (Pa): Total pressure loss.
 X_{0,3}-X_{0,5}-X_{1,0} (m): Throw for terminal velocity of the air stream of 0.3, 0.5, and 1.0 m/s, respectively, in isothermal conditions (ΔT = 0° C).
 V_k (m/s): Effective velocity.

DF-49-MT-3



Catalogue Series DF-49-MT-3



Multinozzle Diffuser



DF-49-MT-3

Product description

Multinozzle plate with high induction and long throw. KOOLAIR, model **DF-49-MT-3**, dimensions $_ \times _$, with $_$ nozzles of $_$ rows. The nozzles can be pointed separately, in all directions, up to a maximum of 30°, they are made in ABS (VO). Plate made in steel sheet, finished painted in RAL 9010, 9005 or 9006. Recommended installation height between 2.5 and 6 m.

Other models

- DF-49-MT-3-E.** Long throw multinozzle to be installed in plaster ceiling. Plate's width of 1.5 mm.
- DF-49-MT-3-SB.** Long throw multinozzle without frame, plate's width of 6 mm.
- DF-49-MT-3-CB.** Long throw multinozzle with frame.

DF-49-MT-3-CC. Long throw multinozzle for circular duct. Maximum two rows of nozzles.

Mounting

- T.** Plate with screw holes. Ready to be screwed.
- MM.** Mounting frame. Fixed with clips. With plenum box made of galvanised steel sheet, with side or top spigot connection (**-PE21/20**). (**-A.** internally insulated).

DF-49-MT-3-CC

Rows	Minimum duct	Maximum duct
1	315	900
2	630	1400

General dimensions

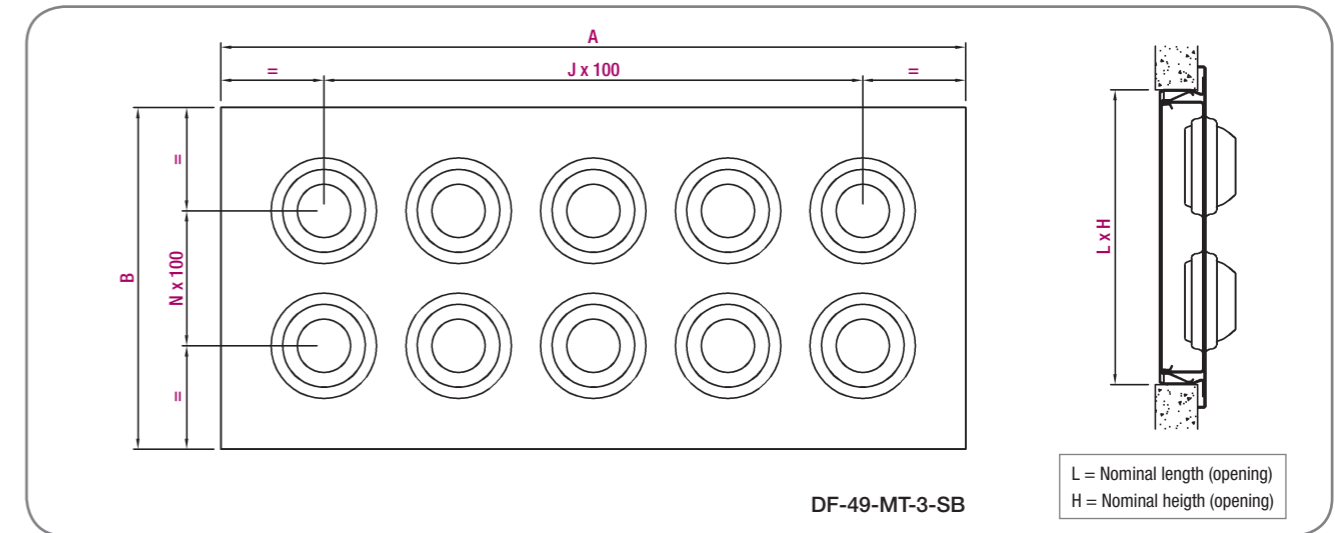

Selection table

Size	Q (m³/h)	L _{wa} [dB(A)]	ΔP _{st} (Pa)	X _{0,3}	X _{0,5}	X _{1,0}
325 x 125	150	24	71	12.1	7.2	3.6
	210	32	128	16.2	9.7	4.9
	280	40	232	21.8	13.1	6.6
525 x 125	230	24	60	14.4	8.6	4.3
	320	32	109	19.3	11.6	5.8
	420	40	196	26.0	15.6	7.8
625 x 125	270	24	56	15.2	9.1	4.6
	370	32	102	20.5	12.3	6.2
	500	40	186	27.7	16.6	8.3
825 x 125	350	24	51	16.8	10.1	5.0
	470	32	93	22.7	13.6	6.8
	630	40	169	>30	18.3	9.1
1025 x 125	420	24	48	18.1	10.9	5.4
	560	32	87	24.4	14.6	7.3
	760	40	157	>30	19.7	9.9
325 x 225	270	24	56	15.2	9.1	4.6
	370	32	102	20.5	12.3	6.2
	500	40	186	27.7	16.6	8.3
525 x 225	420	24	48	18.1	10.9	5.4
	560	32	87	24.4	14.6	7.3
	760	40	157	>30	19.7	9.9
625 x 225	490	24	45	19.3	11.6	5.8
	660	32	82	25.9	15.6	7.8
	890	40	148	>30	21.0	10.5
825 x 225	620	24	41	21.2	12.7	6.4
	840	32	75	28.6	17.2	8.6
	1130	40	135	>30	23.1	11.6
1025 x 225	750	24	38	22.9	13.7	6.9
	1010	32	69	>30	18.5	9.3
	1360	40	126	>30	24.9	12.5

L	Column No.	A	J
325	3	353	2
425	4	453	3
525	5	553	4
625	6	653	5
725	7	753	6
825	8	853	7
925	9	953	8
1025	10	1053	9

Unit mm

H	Range No.	B	N
125	1	153	0
225	2	253	1
325	3	353	2

Unit mm

LEGEND

Q (m³/h): Air flow.
L_{wa} [dB(A)]: Sound power level.
ΔP_{st} (Pa): Static pressure loss.
X_{0,3}-X_{0,5}-X_{1,0} (m): Throw for terminal velocity of the air stream of 0.3, 0.5, and 1.0 m/s, respectively, in isothermal conditions (ΔT = 0° C).

DF-49-MT-3-I/R



Multinozzle Diffuser supply / return



DF-49-MT-3-I/R

Product description

KOOLAIR multi-nozzle diffuser, model **DF-49-MT-3-I/R**, with linear grille for supply and return integrated in plate, dimensions $J \times$ mm. Incorporates 1 or 2 rows of nozzles individually adjustable in all directions up to a maximum of 30°, manufactured in ABS (VO) and finished in RAL 9010, 9005 or 9006. Includes linear grille without frame for return air with blades fixed at an angle of 0° or 45°. Plate made of sheet steel, finished in RAL colour of choice. Option to incorporate regulating damper on supply (-RFS06) or return (-O). Recommended installation height between 2.5 and 6 m.

Models

DF-49-MT-3-E-I/R. Long reach multi-nozzle diffuser set in a flat 1.5 mm thick plate for installation in plaster. Includes a linear return grille with blades at 0°.

DF-49-MT-3-SB-I/R. Long reach multi-nozzle diffuser without frame and a 6 mm thick plate. Includes a linear return grille with blades at 0°.

DF-49-MT-3-E-I/R-45. Long reach multi-nozzle diffuser set in a flat 1.5 mm thick plate for installation in plaster. Includes a linear return grille with blades at 45°.

DF-49-MT-3-SB-I/R-45. Long reach multi-nozzle diffuser without frame and a 6 mm thick plate. Includes a linear return grille with blades at 45°.

Mounting

T. Pre-drilled plate ready for fastening with screws.

PFS. Fixed front connection plenum for supply and/or return air, at 180° with respect to the air outlet. (-A. Interior insulated) Consult for design.

PFL. Fixed lateral connection plenum for supply and/or return air, at 180° with respect to the air outlet. (-A. Interior insulated) Consult for design.

General dimensions

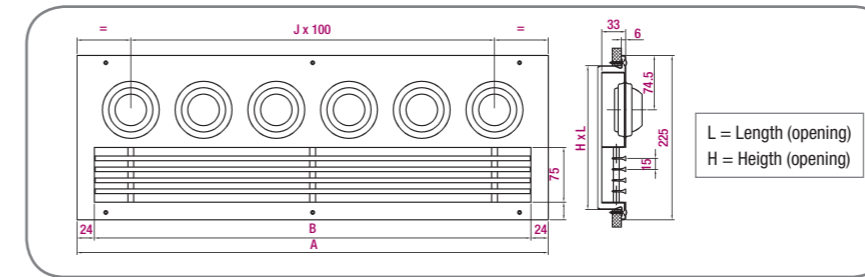

Nozzles	L	H	A	B	J
3T	330	192	353	305	2
4T	430	192	453	405	3
5T	530	192	553	505	4
6T	630	192	653	605	5
7T	730	192	753	705	6
8T	830	192	853	805	7
9T	930	192	953	905	8
10T	1030	192	1053	1005	9

Unit mm

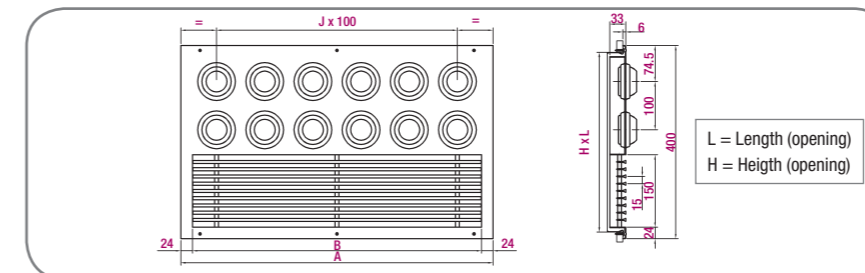

Nozzles	L	H	A	B	J
3T	330	367	353	305	2
4T	430	367	453	405	3
5T	530	367	553	505	4
6T	630	367	653	605	5
7T	730	367	753	705	6
8T	830	367	853	805	7
9T	930	367	953	905	8
10T	1030	367	1053	1005	9

Unit mm

Selection table

Size	Q (m³/h)	Supply					Return	
		L _{WA} [dB(A)]	ΔP _{st} (Pa)	X _{0,3}	X _{0,5}	X _{1,0}	L _{WA} [dB(A)]	ΔP _{st} (Pa)
330 x 192	150	24	71	12,1	7,2	3,6	23	7
	210	32	128	16,2	9,7	4,9	31	15
	280	40	232	21,8	13,1	6,6	39	26
530 x 192	230	24	60	14,4	8,6	4,3	22	6
	320	32	109	19,3	11,6	5,8	30	11
	420	40	196	26,0	15,6	7,8	37	19
630 x 192	270	24	56	15,2	9,1	4,6	22	6
	370	32	102	20,5	12,3	6,2	30	10
	500	40	186	27,7	16,6	8,3	38	19
830 x 192	350	24	51	16,8	10,1	5,0	23	5
	470	32	93	22,7	13,6	6,8	30	10
	630	40	169	>30	18,3	9,1	38	17
1030 x 192	420	24	48	18,1	10,9	5,4	21	4
	560	32	87	24,4	14,6	7,3	28	7
	760	40	157	>30	19,7	9,9	36	14
330 x 367	270	24	56	15,2	9,1	4,6	25	7
	370	32	102	20,5	12,3	6,2	33	13
	500	40	186	27,7	16,6	8,3	41	25
530 x 367	420	24	48	18,1	10,9	5,4	25	6
	560	32	87	24,4	14,6	7,3	33	11
	760	40	157	>30	19,7	9,9	41	21
630 x 367	490	24	45	19,3	11,6	5,8	24	5
	660	32	82	25,9	15,6	7,8	31	9
	890	40	148	>30	21,0	10,5	39	17
830 x 367	620	24	41	21,2	12,7	6,4	24	5
	840	32	75	28,6	17,2	8,6	32	9
	1130	40	135	>30	23,1	11,6	39	15
1030 x 367	750	24	38	22,9	13,7	6,9	24	4
	1010	32	69	>30	18,5	9,3	32	8
	1360	40	126	>30	24,9	12,5	39	14

LEGEND

Q (m³/h): Air flow.
L_{WA} [dB(A)]: Sound power level.
ΔP_{st} (Pa): Static pressure loss.
X_{0,3}-X_{0,5}-X_{1,0} (m): Throw for terminal velocity of the air stream of 0.3, 0.5, and 1.0 m/s, respectively, in isothermal conditions (ΔT = 0° C).

DGV



Catalogue Series DGV



Variable geometry diffuser

Product description

Variable-geometry diffuser, KOOLAIR, **DGV** round, constructed of steel. External ring in notched aluminium. The standard finish is RAL 9010 white paint. By special order, the diffuser can be painted in any RAL colour.

Other models

DGV-TR. Variable geometry diffuser autoregulated by thermal element.

Available up to size 500.

DGV-MT. Variable geometry diffuser with motorised mechanism.

Mounting

PCFL-RE. Side entry plenum box with volumetric control damper in the spigot connection.



General dimensions

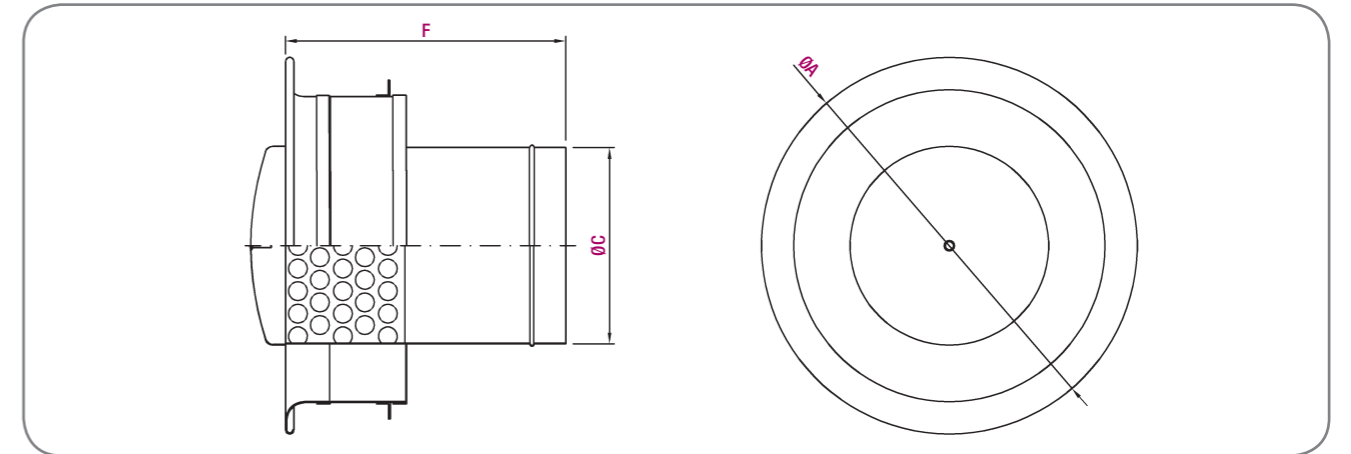

Nominal	Ø A	Ø C	F
250	425	249	440
315	500	314	440
400	600	399	440
500	730	499	440
630	900	629	580

Unit mm

Selection table (Vertical discharge)

Size	Q (m³/h)	L _{WA} [dB(A)]	ΔP _t (Pa)	Y (m)
250	578	35	28	5,2
	692	40	41	6,2
	829	45	58	7,5
315	724	35	19	5,5
	867	40	27	6,6
	1039	45	39	7,9
400	1162	40	21	6,7
	1391	45	30	8,0
	1666	50	43	9,5
500	1604	40	21	7,2
	1921	45	31	8,7
	2301	50	44	10,4
630	2339	40	22	8,1
	2802	45	32	9,7
	3356	50	46	11,6

Selection table (Horizontal discharge)

Size	Q (m³/h)	L _{WA} [dB(A)]	ΔP _t (Pa)	X (m)
250	637	35	35	3,4
	763	40	49	4,1
	914	45	71	4,9
315	823	35	25	3,9
	985	40	36	4,7
	1180	45	51	5,6
400	1359	40	28	5,6
	1627	45	41	6,7
	1949	50	58	8,0
500	1921	40	31	6,7
	2301	45	44	8,0
	2756	50	64	9,6
630	2856	40	33	8,2
	3421	45	47	9,9
	4097	50	68	11,8

LEGEND

Q (m³/h): Air flow.

L_{WA} [dB(A)]: Sound power level.

ΔP_t (Pa): Total pressure loss.

Y (m): Vertical penetration for a terminal air vein velocity of 0.20 m/s and ΔT = +10° C.

X (m): Throw for a maximum velocity of 0.25 m/s at the occupied zone, with ceiling effect.

DVP



Catalogue Series DVP



Adjustable blade variable geometry diffuser

Product description

The adjustable blade variable geometry diffuser, KOOLAIR, model **DVP** provides an optimum discharge in cooling (horizontal discharge) and heating (vertical discharge) enabling the diffuser to meet the required comfort criteria. Made in steel sheet. Finished painted in RAL to define.

Mounting

PCFL-RE. Side entry plenum box with volumetric control damper in the spigot connection.

Other models

DVP-TR. Variable geometry diffuser autoregulated by thermal element. (From Ø250 to Ø630).

DVP-MT. Variable geometry diffuser with motorised mechanism. (From Ø160).

DVP-Q. Diffuser of variable blade geometry built into 595x595-mm plate (up to Ø500).

DVP-Q-TR. Diffuser of variable blade geometry, self-regulating, fitted with thermal component built into 595x595-mm plate. (Ø250 to Ø500).

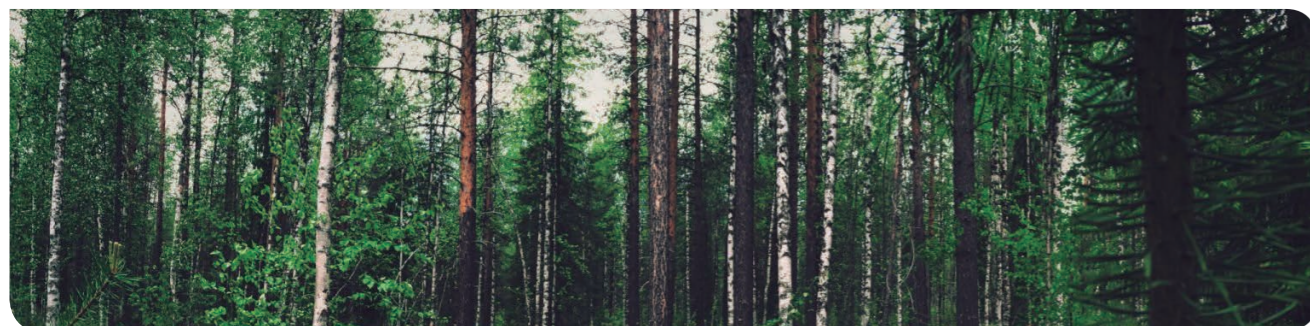

General dimensions

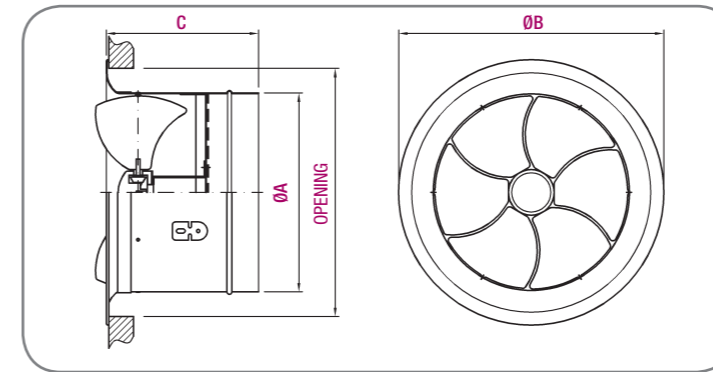

Model	OPENING	Ø A	Ø B	C
160	215	159	253	155
200	255	199	303	174
250	305	249	353	200
315	370	314	418	240
355	410	354	458	250
400	455	399	503	265
500	555	499	600	320
630	685	629	730	380
800	855	799	900	555

Unit mm

Selection table (Vertical discharge)

Size	Q (m³/h)	L _{wa} [dB(A)]	ΔP _t (Pa)	Y (m)
160	160	25	12	1,5
	220	35	23	2,1
	310	45	45	3,0
200	250	25	12	1,7
	350	35	23	2,4
	465	45	41	3,2
250	475	30	24	2,2
	575	35	36	2,7
	675	40	49	3,1
315	950	35	30	3,2
	1.250	45	52	4,2
	1.500	50	75	5,0
355	1.050	35	23	2,6
	1.475	45	45	3,7
	1.750	50	63	4,3
400	1.550	40	30	3,4
	1.800	45	41	4,0
	2.150	50	58	4,7
500	2.400	40	25	4,1
	2.800	45	35	4,7
	3.400	50	51	5,7
630	3.750	40	20	4,5
	4.500	45	29	5,4
	5.400	50	42	6,5
800	7.300	45	23	6,2
	8.500	50	32	7,2
	9.500	55	40	8,0

LEGEND

Q (m³/h): Air flow.

L_{wa} [dB(A)]: Sound power level.

ΔP_t (Pa): Total pressure loss.

Selection table (Horizontal discharge)

Size	Q (m³/h)	L _{wa} [dB(A)]	ΔP _t (Pa)	X (m)
160	125	25	23	1,0
	175	35	44	1,4
	250	45	90	2,1
200	190	25	21	1,3
	260	35	39	1,8
	310	45	55	2,1
250	330	30	25	2,1
	400	35	36	2,5
	475	40	51	3,0
315	675	35	45	3,7
	925	45	85	4,7
	1.080	50	116	5,4
355	750	35	36	3,5
	1.050	45	71	4,9
	1.200	50	93	5,6
400	1.000	40	42	4,6
	1.200	45	61	5,6
	1.400	50	83	6,5
500	1.400	40	32	5,2
	1.700	45	47	6,3
	2.000	50	65	7,4
630	2.000	40	26	5,2
	2.400	45	37	6,2
	2.800	50	51	7,3
800	3.300	45	30	6,2
	3.900	50	42	7,3
	4.500	55	55	8,5

Y (m): Throw for a terminal velocity of the air stream of 0.25 m/s, with ΔT = +10° C.

X (m): Throw for a maximum velocity of 0.25 m/s at the occupied zone, in isothermal conditions ΔT = 0° C.

Square diffusers



50-FR-4 (128)

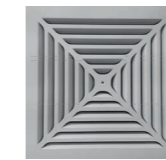

52-FR-4-STAMP (130)

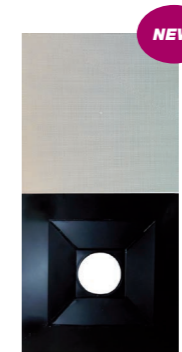

56-FR (132)

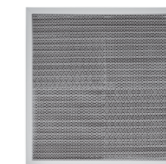

54-FR-I-4 (134)



KLD-Q-PANEL (136)



KLD-Q-VR (138)



KCD-Q (140)

Convention Centre (Dublin – Ireland)

Variable geometry diffuser DGV,
linear diffusers LK-70,
long-throw diffuser DF-47
and step swirl diffusers DF-CP-MT.

50-FR-4



Catalogue Series 50

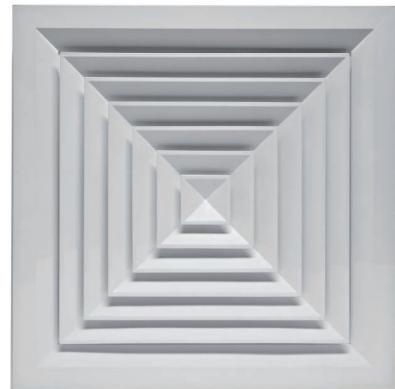

Square diffuser

Product description

Square diffuser with easily removable central core, KOOLAIR, model **50-FR-4**, dimensions $L \times H$ mm, to supply air in 4 ways. It can incorporate flap damper (**59MM**) or opposed blade damper (**-O**).

Fixing accessories to be determined. Made in aluminium. Finished in anodised aluminium or any RAL colour upon request.

Recommended installation height between 2.5 and 4 m.

Mounting

PM. Mounting bridge for fibre ducts.

PMC. Mounting bridge for sheet ducts.

SM. Concealed fixing, by hanging brackets in the diffuser's neck.

PE41. Side connection plenum box made in galvanised steel sheet.

PE40. Top connection plenum box made in galvanised steel sheet.

On demand isolation and regulation damper in the spigot connection.

Other models

50-FR-4-Q. Four ways square diffuser integrated in plate of 595x595, to be installed in false ceiling.

50-FR-1. One way square diffuser. Made in aluminium, of dimensions $L \times H$.

50-FR-1-L. One way rectangular diffuser. Made in aluminium, of dimensions $L \times H$.

50-FR-2. Two ways square diffuser. Made in aluminium, of dimensions $L \times H$.

50-FR-2-L. Two ways rectangular diffuser. Made in aluminium, of dimensions $L \times H$.

50-FR-3. Three ways square diffuser. Made in aluminium, of dimensions $L \times H$.

50-FR-2D. Rectangular diffuser with central core in two directions at 90°.

General dimensions

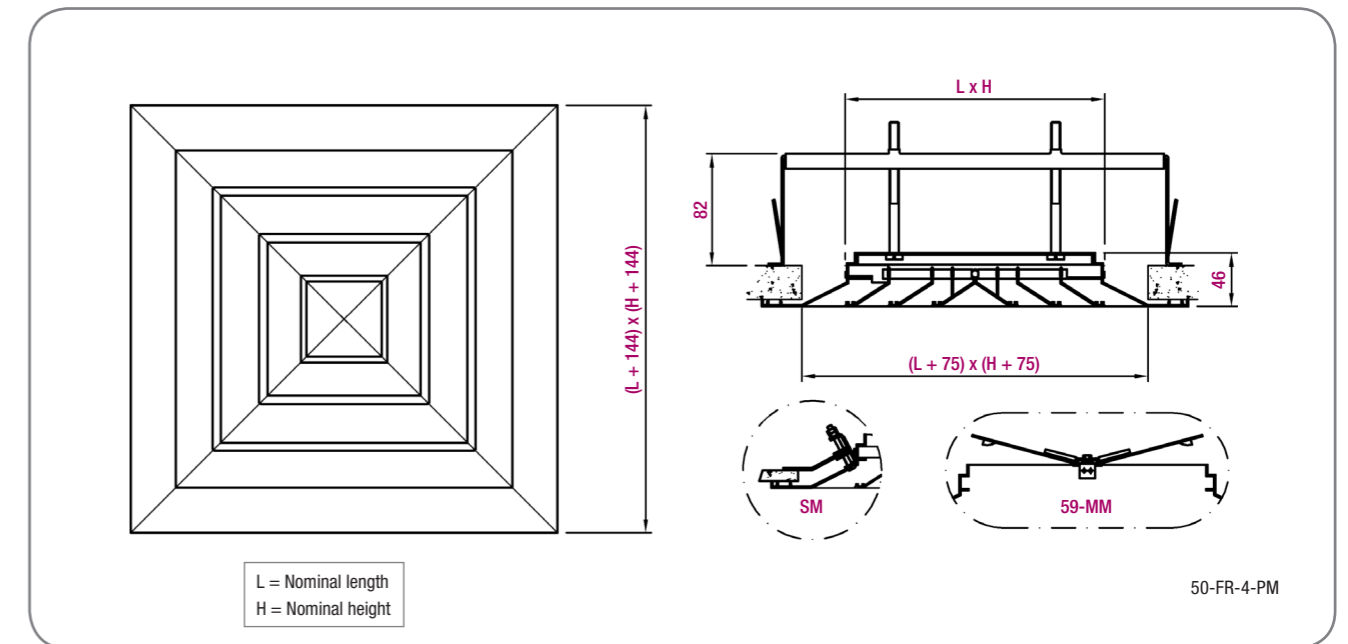

Dimensions from 150x150 to 600x600 in 75mm increments.

Selection table

Size	Dimension	Q (m³/h)	L _{wa} [dB(A)]	ΔP _t (Pa)	X (m)	V _k (m/s)
6 x 6	150 x 150	110	24	6	0.7	2.8
		150	32	11	1	3.9
		210	40	20	1.3	5.4
9 x 9	225 x 225	210	24	4	0.9	2.4
		300	32	8	1.2	3.4
		410	40	15	1.7	4.7
12 x 12	300 x 300	350	24	3	1.1	2.2
		480	32	7	1.5	3.1
		660	40	12	2.1	4.2
15 x 15	375 x 375	500	24	3	1.2	2
		690	32	6	1.7	2.8
		950	40	11	2.4	3.9
18 x 18	450 x 450	670	24	3	1.4	1.9
		930	32	5	1.9	2.6
		1290	40	9	2.7	3.7
21 x 21	525 x 525	870	24	2	1.6	1.8
		1200	32	4	2.1	2.5
		1660	40	8	3	3.5
24 x 24	600 x 600	1080	24	2	1.7	1.7
		1500	32	4	2.3	2.4
		2070	40	8	3.2	3.3



LEGEND

Q (m³/h): Air flow.

L_{wa} [dB(A)]: Sound power level.

ΔP_t (Pa): Total pressure loss.

X (m): Throw for a maximum velocity of 0.25 m/s at the occupied zone
ΔT = -10 °C (cold), installed at a height of 3m.

V_k (m/s): Effective velocity.

52-FR-4-STAMP



Catalogue Series 50



Square diffuser

Product description

Stamped square diffuser with stationary central core for air supply in four directions, Koolair **52-FR-4-STAMP** model, nominal dimension x mm, suitable for cold and hot air supply.
Air flow pattern in 4 directions.
Recommended installation height of 2.5 to 4 m.

Mounting

- PDS-RE.** Top connection plenum box made in galvanised steel sheet, without insulation.
- PDL-RE.** Side connection plenum box made in galvanised steel sheet, without insulation.
- PDS-A-RE.** Top connection plenum box made in galvanised steel sheet, insulated.
- PDL-A-RE.** Side connection plenum box made in galvanised steel sheet, insulated.

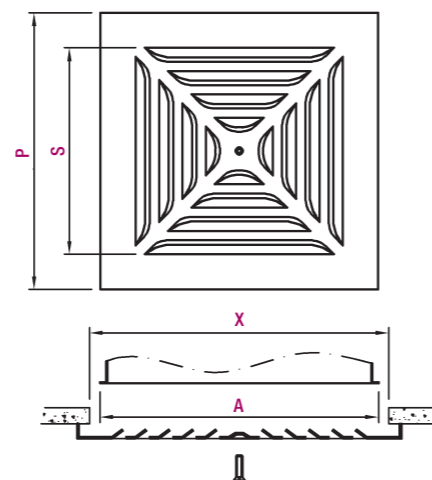

Dimensions

Nominal	A	P	S	X
150	215	295	182	190
225	290	370	257	265
300	365	445	332	340
375	440	520	407	415
450	515	595	482	490
500	590	625	557	565
525	590	670	557	565
600	665	745	632	640

Unit in mm

General dimensions (side connection plenum)

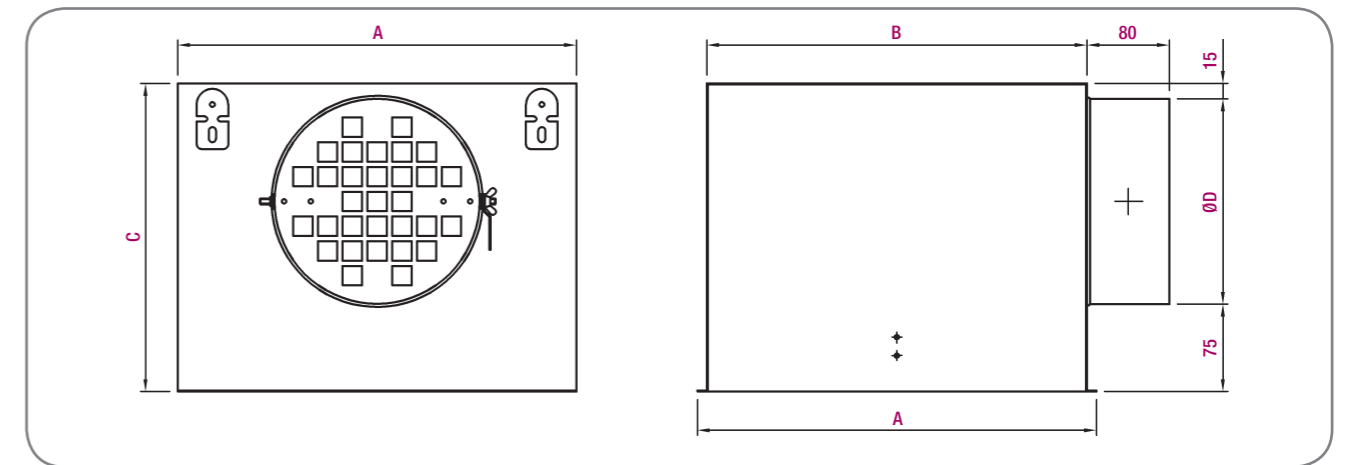

Custom plenums available to suit reduced heights above false ceilings.

Nominal	A (Ext.)	B	C	Ø D (Ext.)
150	215	195	214	124
225	290	270	249	159
300	365	345	269	199
375	440	420	339	249
450	515	495	404	314
500	590	570	404	314
525	590	570	404	314
600	665	645	444	354

Unit mm

Selection table

Nominal	Q (m³/h)	L _{WA} [dB(A)]	ΔP _t (Pa)	X (m)	V _k (m/s)
150	120	24	6	0,8	1,6
	165	32	12	1,0	2,2
	230	40	23	1,5	3,1
225	185	24	4	0,9	1,2
	260	32	7	1,2	1,8
	360	40	14	1,7	2,4
300	340	24	8	1,5	2,2
	460	32	14	2,0	2,9
	650	40	28	2,8	4,2
375	435	24	4	1,8	2,4
	590	32	7	2,4	3,3
	840	40	15	3,4	4,7
450	525	24	3	1,9	2,4
	710	32	6	2,6	3,2
	990	40	11	3,6	4,5
500 / 525	715	24	4	2,3	2,4
	990	32	7	3,2	3,4
	1350	40	13	4,3	4,6
600	1250	24	6	3,4	3,1
	1750	32	11	4,7	4,3
	2500	40	23	6,8	6,2

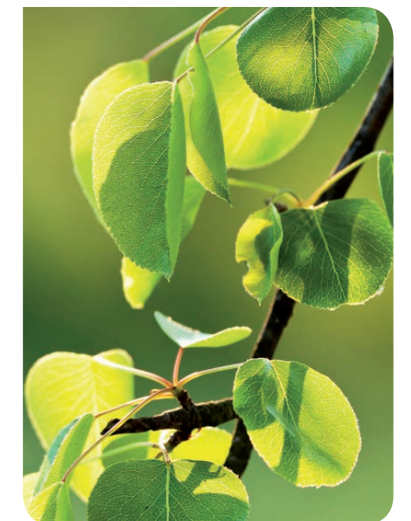

LEGEND

- Q (m³/h): Air flow.
- L_{WA} [dB(A)]: Sound power level.
- ΔP_t (Pa): Total pressure loss.
- X (m): Throw for a maximum velocity of 0.25 m/s at the occupied zone ΔT = -10 °C (cold), installed at a height of 3m.
- V_k (m/s): Effective velocity.

56-FR

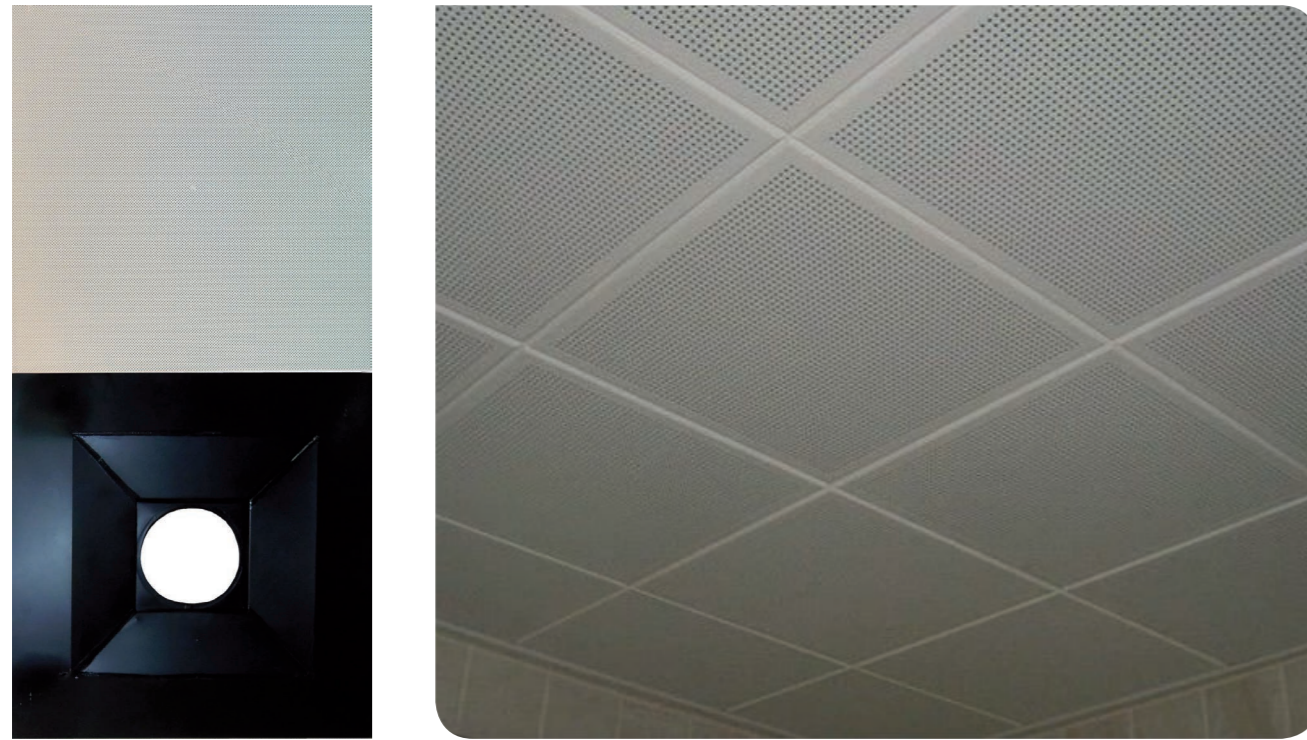

Hidden square diffuser

Product description

KOOLAIR square diffuser, model **56-FR-Q-PR**, nominal dimensions $_x_ \text{ mm}$ incorporated in 595x595 mm micro-perforated tile. Incorporates a set of internal directional vanes that can be manually configured to supply air in 1,2,3 or 4 directions either during commissioning or by the end user. Option to include plenum for lateral connection and regulating damper.

Available or adaptable to micro-perforated suspended ceiling tiles with a free area between 16% and 50%, covering a large part of the range of existing standard micro-perforated ceilings on the market.

Made entirely of sheet steel. Finished ceiling tile painted in RAL colour to be defined; interior diffuser in RAL9005 (black) to prevent it from being seen and guarantee discretion.

They achieve one of the design premises most sought after by architects and designers: to completely hide the components of the air conditioning installation. The air diffusion unit is integrated above the micro-perforated ceiling tiles (inside the false ceiling), giving total aesthetic uniformity to the space.

Recommended installation height between 2.4 and 3.5 m.

Mounting

PFL-RE. Fixed plenum box without internal insulation, with manual damper accessible from false ceiling.

PFL-A-RE. Fixed plenum box with side connection internally insulated, with manual damper accessible from false ceiling.

Note: On request, top plenum available insulated/uninsulated (PFS-A-RE/PFS-RE).

Other models

56-FR-Q. Square diffuser ready to be integrated in an existing microperforated plate of dimensions 595x595 in a false ceiling.

56-FR-PR-Plate LxH. Square diffuser integrated in a microperforated plate of dimensions $_x_ \text{ mm}$.

56-FR-Plate LxH. Square diffuser ready to be integrated in an existing microperforated plate of dimensions $_x_ \text{ mm}$ in a false ceiling.

56-FR-R-PR-Q. Square return diffuser incorporated on a 595x595 mm micro-perforated tile.

56-FR-R-PR-Placa LxH. Square return diffuser incorporated on a $_x_ \text{ mm}$ micro-perforated tile.

56-FR-R-Q. Square return diffuser ready to be integrated on a 595x595 mm micro-perforated tile.

56-FR-R-Plate LxH. Square return diffuser ready to be integrated on a $_x_ \text{ mm}$ micro-perforated tile.

General dimensions

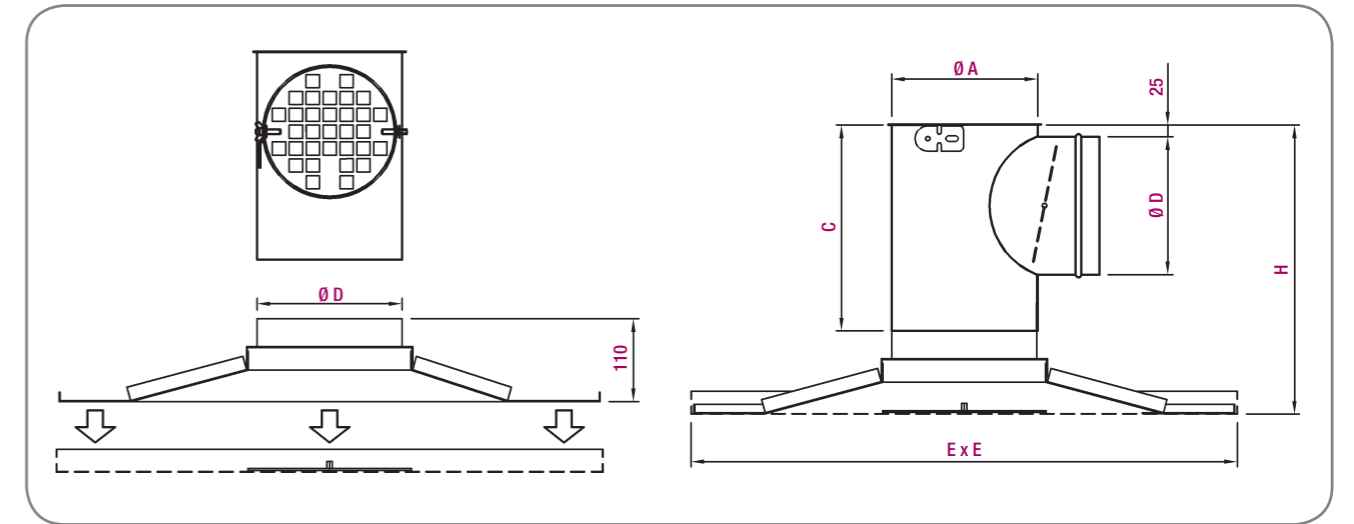

Custom plenums available to suit reduced heights above false ceilings.

Model	A	C	Ø D	H	E x E
200	103	169	98	265	595x595
250	103	169	98	265	
315	128	194	123	220	
400	163	229	158	325	
500	203	269	198	365	
600	253	319	248	415	625x625
625	253	319	248	415	

Unit in mm

Selection table

Size	Q (m ³ /h)	L _{wa} [dB(A)]	ΔP _t (Pa)	X (m)
200	60	24	5	0,5
	80	32	10	0,9
	110	40	18	1,0
250	75	24	6	0,7
	100	32	11	1,1
	135	40	20	1,3
315	95	24	6	0,8
	125	32	12	1,1
	170	40	22	1,4
400	125	24	7	1,2
	170	32	12	1,3
	230	40	23	1,6
500	180	24	6	1,2
	245	32	12	1,5
	330	40	22	1,9
600 / 625	260	24	6	1,3
	350	32	11	1,7
	475	40	21	2,0

Technical data for micro-perforated tile with 50% free area.
Availability of other perforation designs. Consult the Technical Department.



LEGEND

Q (m³/h): Air flow.
L_{wa} [dB(A)]: Sound power level.
ΔP_t (Pa): Total pressure loss.
X (m): Throw for a maximum velocity of 0.25 m/s at the occupied zone
ΔT = -10 °C (cold), installed at a height of 2.8 m.

54-FR-I-4



Catalogue Series 50-PR

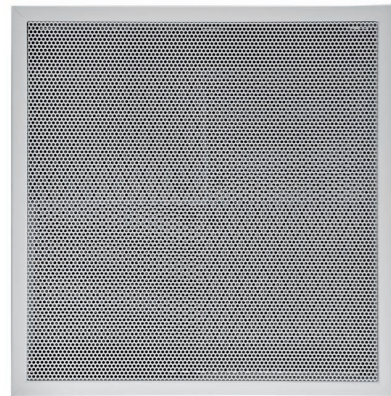

Square perforated face diffusers

Product description

Square perforated face diffuser, Koolair, model **56-FR-I-4**, dimension _x_. Incorporates interior directional plates for supplying air in four directions. It incorporates plenum box made in galvanised steel sheet. Finished painted in any RAL colour upon request. It's possible to install it in false ceilings of 600x600 mm. Recommended installation height between 2.5 and 4 m.

Mounting

- PFS.** Top connection plenum box made in galvanised steel sheet.
- PFL.** Side connection plenum box made in galvanised steel sheet.
- PFS-A.** Top connection plenum box internally insulated made in galvanised steel sheet.
- PFL-A.** Side connection plenum box internally insulated made in galvanised steel sheet.

Other models

- 54-FR-I-1.** One direction square perforated face diffuser of dimension LxH.
- 54-FR-I-2.** Two directions square perforated face diffuser of dimension LxH.
- 54-FR-I-0.** Square perforated face diffuser for vertical air supply, of dimension LxH.
- 54-FR-R.** Square perforated face diffuser for returning air, of dimension LxH.



General dimensions

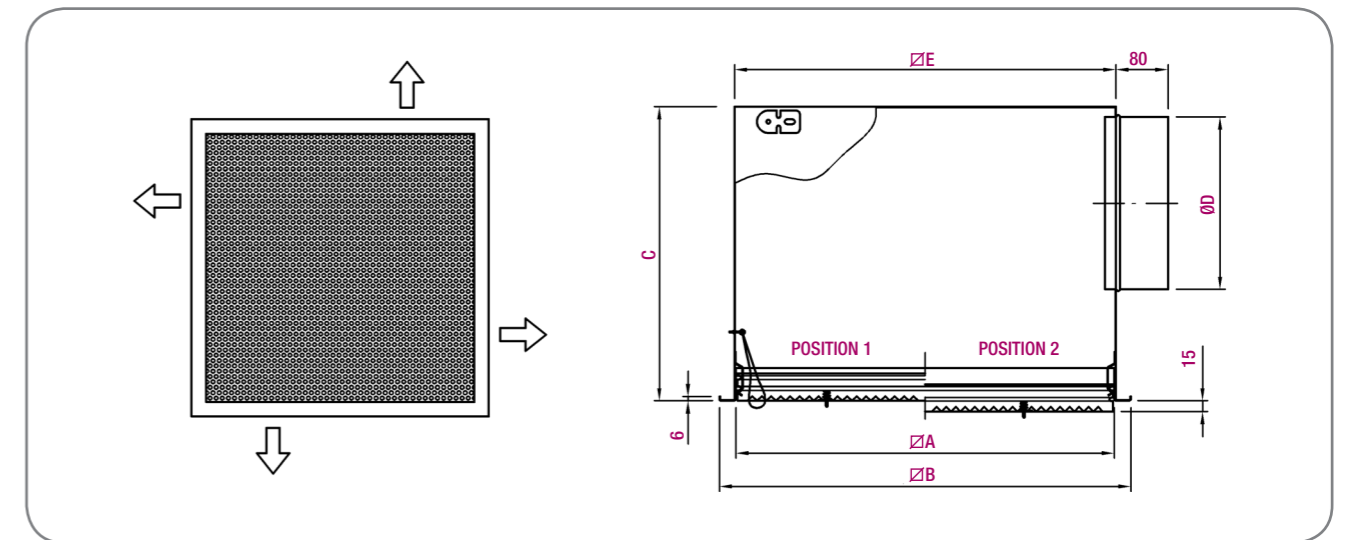

Custom plenums available to suit reduced heights above false ceilings.

Nominal	A	B	C	ØD	E
160 - 300	251	299	250	160	256
200 - 400	351	399	300	200	356
250 - 500	451	499	355	250	456
315 - 600	547	595	425	315	552
315 - 625	576	624	425	315	581

Unit mm

Selection table

Size	Q (m³/h)	L _{wa} [dB(A)]	ΔP _t (Pa)	V _k (m/s)	X (m)
300 x 300	140	24	7	1.3	0.9
	180	32	11	1.7	1.1
	230	40	18	2.1	1.4
400 x 400	250	24	6	1.2	1.1
	320	32	9	1.5	1.4
	410	40	15	1.9	1.8
500 x 500	390	24	5	1.1	1.3
	500	32	8	1.4	1.7
	640	40	14	1.8	2.2
600 x 600	550	24	5	1.1	1.5
	700	32	7	1.3	2.0
	900	40	12	1.7	2.5
625 x 625	600	24	5	1.0	1.6
	760	32	7	1.3	2.0
	980	40	12	1.7	2.6



LEGEND

- Q (m³/h): Air flow.
- L_{wa} [dB(A)]: Sound power level.
- ΔP_t (Pa): Total pressure loss.
- X (m): Throw for a maximum velocity of 0.25 m/s at the occupied zone
- ΔT = -10 °C (cold), installed at a height of 3m.
- V_k (m/s): Effective velocity.

KLD-Q-PANEL



Catalogue Series KFD-KLD



Square diffuser

Product description

Four ways supply square diffuser, suitable for variable and constant air volume, KOOLAIR, model **KLD-Q-PANEL**, of dimensions 595x595 mm, with _ number of slot/s (1 to 4). Frame made in extruded aluminium and central core panelled like the false ceiling. Finished painted in any RAL colour upon request. It incorporates connection plenum box made in galvanised steel sheet.

It is possible to manufacture it in other dimensions. Recommended installation height between 2.5 and 4 m.

Other models

KLD-Q. Four ways diffuser of 1 to 4 slots, central core made in steel sheet painted in RAL colour upon request.

KLD-Q-FLASH. Four ways diffuser of 2 slots, with luminaires integrated at the central core.

Mounting

PFL. Side connection plenum box made in galvanised steel sheet.

PFL-A. Side connection plenum box internally insulated made in galvanised steel sheet.

PFS. Top connection plenum box made in galvanised steel sheet.

PFS-A. Top connection plenum box internally insulated made in galvanised steel sheet.

Note: For accessible volume control damper from the room please ask specifically on order.

General dimensions

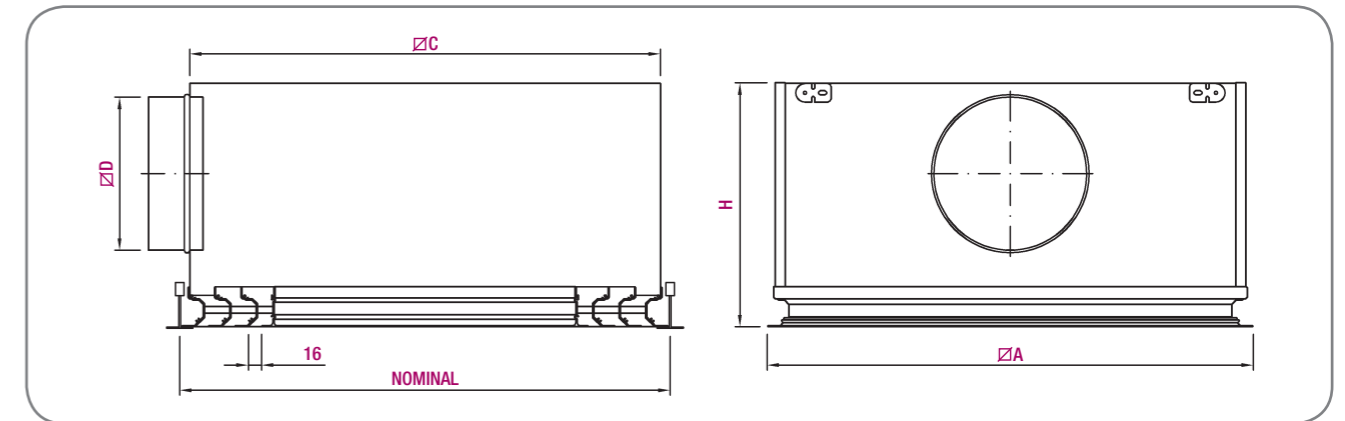

Custom plenums available to suit reduced heights above false ceilings.

Nominal	N. of slots	Ø D	A	C	H
600 x 600	1	199	595	586	320
	2, 3 and 4	249			
675 x 675	1	199	670	661	320
	2, 3 and 4	249			

Unit mm

Selection table (600x600 mm)

N. of slots	Q (m³/h)	L _{wa} [dB(A)]	ΔP _t (Pa)	X (m)	V _k (m/s)
1	270	24	9	2,7	1,5
	400	32	20	4,0	2,3
	580	40	43	5,8	3,3
2	350	24	5	2,0	1,5
	520	32	12	3,0	2,2
3	750	40	24	4,4	3,2
	420	24	4	1,7	1,5
4	620	32	8	2,6	2,2
	900	40	17	3,6	3,3
4	450	24	3	0,9	1,6
	650	32	7	1,3	2,3
	975	40	15	2,0	3,5

LEGEND

Q (m³/h): Air flow.
 L_{wa} [dB(A)]: Sound power level.
 ΔP_t (Pa): Total pressure loss.
 X (m): Throw for a maximum velocity of 0.25 m/s at the occupied zone
 ΔT = 0 °C (isothermal conditions), installed at a height of 3m.
 V_k (m/s): Effective velocity.



KLD-Q-I/R



Catalogue Series KFD-KLD



Square diffuser

Product description

Four-way square diffuser for variable or constant volume systems KOOLAIR model **KLD-Q-I/R**, 2, 3 or 4 ways, for integrated supply and extract in the same unit. Perforated sheet metal central core for air extract.

Foldable option available with frame to hold filter.

Made from extruded aluminium sections.

Incorporates two plenums with independent connections (supply and extract) made of galvanized steel sheet, with regulating damper on spigot.

Possibility of manufacturing with other dimensions.

Recommended installation height between 2.5 and 4 m. Painted finish in RAL colour of choice.

Other models

KLD-Q-I/R-PF. Four-way square diffuser for supply and extract air with folding central core and frame to hold filter.

Mounting

PFL. Side connection plenum box made in galvanised steel sheet.

PFL-A. Side connection plenum box internally insulated made in galvanised steel sheet.

Note: For accessible volume control damper from the room please ask specifically on order.

General dimensions

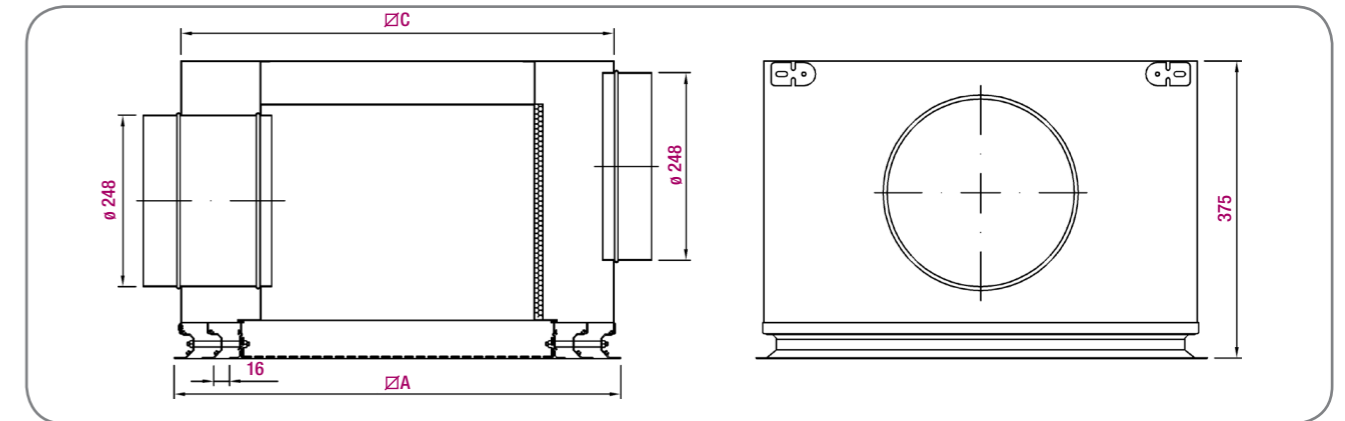

Nominal	N. of slots	ØA	ØC
600 x 600	2, 3 and 4	595	576
675 x 675	2, 3 and 4	670	651

Unit mm

Selection table (600x600 mm)

N. of slots	Q (m³/h)	L _{wa} [dB(A)]	ΔP _t (Pa)	X (m)	V _k (m/s)
2	301	24	6	1,0	2,2
	422	32	12	1,4	3,1
	592	40	24	2,0	4,4
3	411	24	6	1,1	2,2
	576	32	11	1,5	3,0
	807	40	22	2,1	4,2

LEGEND

Q (m³/h): Air flow.
 L_{wa} [dB(A)]: Sound power level.
 ΔP_t (Pa): Total pressure loss.
 X (m): Throw for a maximum velocity of 0.25 m/s at the occupied zone
 ΔT = 0 °C (isothermal conditions), installed at a height of 3m.
 V_k (m/s): Effective velocity.



KCD-Q



Square diffuser

Product description

Four-way square diffuser for variable or constant flow installations, KOOLAIR model **KCD-Q**, dimensions 595x595 mm, with variable ways (1 to 4). Made entirely of sheet steel with a central core that has the same design as the attached ceiling plate. Painted finish in RAL colour of choice. Incorporates plenum with connection made of galvanized steel sheet. Possibility of manufacturing with other dimensions. Recommended installation height between 2.5 and 4 m.

Other models

KCD-Q-I/R. Four-way square diffuser with 2 or 3 ways, to integrate supply and extract air in the same plate. Perforated sheet metal central core.

KCD-Q-I/R-PF. Four-way square diffuser with 2 or 3 ways, to integrate supply and extract air in the same plate. Foldable perforated sheet metal central core with frame to hold filter.

KCD-Q-FLASH. Four-way square diffuser with 2 ways, with integrated luminaire in the central core.

Mounting

PFL. Side connection plenum box made in galvanised steel sheet.

PFL-A. Side connection plenum box internally insulated made in galvanised steel sheet.

Note: For accesible volume control damper from the room please ask specifically on order.

General dimensions

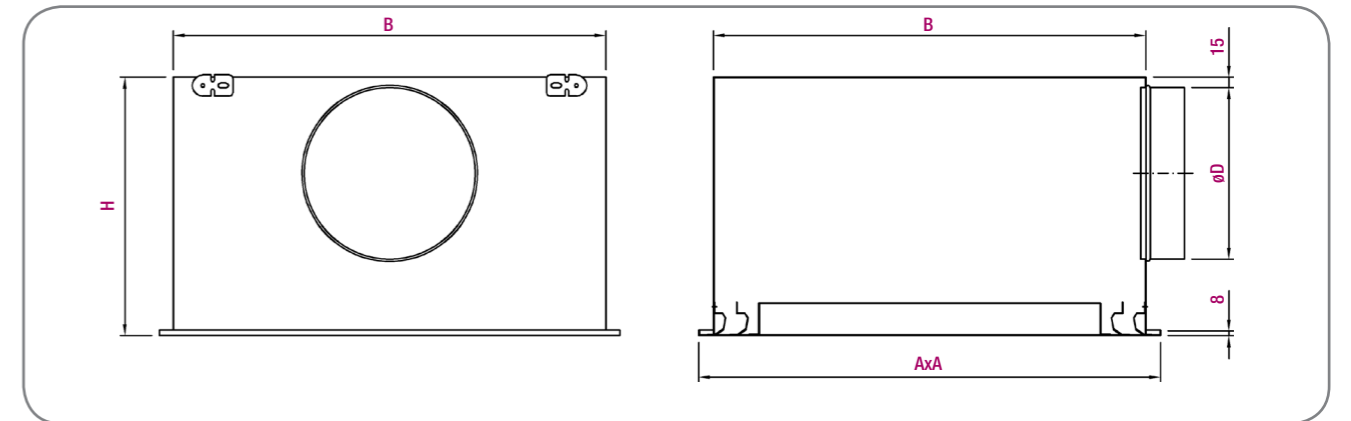

Custom plenums available to suit reduced heights above false ceilings.

Nominal	A	B	ØD	H
600 x 600	595	566	249	375
675 x 675	670	631	249	375

Unit mm

Selection table (600x600 mm)

N. of slots	Q (m³/h)	L _{wa} [dB(A)]	ΔP _t (Pa)	X (m)	V _k (m/s)
1	247	24	9	2,0	3,1
	333	32	16	2,6	4,2
	449	40	28	3,6	5,7
2	346	24	6	2,3	2,8
	466	32	11	3,1	3,8
3	629	40	20	4,2	5,2
	422	24	6	2,5	2,7
	569	32	11	3,4	3,6
4	767	40	20	4,6	4,9
	485	24	4	2,0	2,6
	654	32	7	2,6	3,5
	882	40	13	3,6	4,7

LEGEND

Q (m³/h): Air flow.
 L_{wa} [dB(A)]: Sound power level.
 ΔP_t (Pa): Total pressure loss.
 X (m): Throw for a maximum velocity of 0.25 m/s at the occupied zone
 ΔT = 0 °C (isothermal conditions), installed at a height of 3m.
 V_k (m/s): Effective velocity.



Linear diffusers



Alcorcón City Hall (Madrid - Spain)

Grilles 20-45-H, 21-SVC and 22-5,
linear grille 31-1,
extract valves GPD,
linear diffusers S-74,
long throw multinozzle MT3.CC-T,
outside air inlet louvres 210-TA,
overpressure dampers 230-SP,
air volume control dampers AOBD-102-E
and rectangular fire dampers SFR2-TH-70.

LK-70



Catalogue Series LK-70

Linear slot diffuser



Product description

Linear diffuser, highly aesthetic, for variable or constant airflow with adjustable directional blades by a wheel mechanism, KOOLAIR, model **LK-70**, of _ mm long and _ slots. Slot width of 15 mm and narrow exterior frames. Incorporates side connection plenum box made in sheet steel, with volume control damper at the entry of it accessible from the room. Frames made in extruded aluminium and deflection blades in aluminium. Finished in anodised aluminium or painted in RAL colour upon request. Recommended installation height between 2.5 and 4 m.

Note: Possible to form continuous lines (Maximum length per section 2000 mm).

On request, top plenum available insulated/ uninsulated (PFS-A/PFS / PDS-A/PDS).

Selection table

(Flow rate per linear metre of diffuser)

No. of ways	Dimension	Q (m³/h)	L _{WA} [dB(A)]	ΔP _t (Pa)	X (m)	V _k (m/s)
1	1000	66	24	7	2.7	2.0
		96	32	14	3.9	2.9
		138	40	29	5.6	4.2
2	1000	110	24	5	3.1	1.7
		158	32	10	4.5	2.4
		227	40	20	6.5	3.4
3	1000	176	24	5	4.1	1.8
		248	32	10	5.8	2.5
		350	40	21	8.2	3.5
4	1000	214	24	4	4.3	1.6
		302	32	9	6.1	2.3
		427	40	17	8.6	3.3

The Selection Table shows a summary of dimensions. Other sizes available. Consult the Sales Department.

Mounting

PFL-RL. Fixed side connection plenum box, without internal insulation made in galvanised sheet steel.

PFL-A-RL. Fixed side connection plenum box, internally insulated made in galvanised sheet steel.

PDL-RL. Removable, by bridges, side connection plenum box, without insulation and made in galvanised sheet steel.

PDL-A-RL. Removable, by bridges, side connection plenum box, internally insulated and made in galvanised sheet steel.

PM. With mounting bridge.

Other models

LK-70-S. Slot diffuser, narrow outer section (12 mm).

LK-70-MULTI. Linear slot diffuser with possibility of changing the vein of air each 100 mm.

LEGEND

Q (m³/h): Air flow.

L_{WA} [dB(A)]: Sound power level.

ΔP_t (Pa): Total pressure loss.

X (m): Throw for a maximum velocity of 0.25 m/s at the occupied zone

ΔT = 0 °C (isothermal conditions),

installed at a height of 3m.

V_k (m/s): Effective velocity.

General dimensions

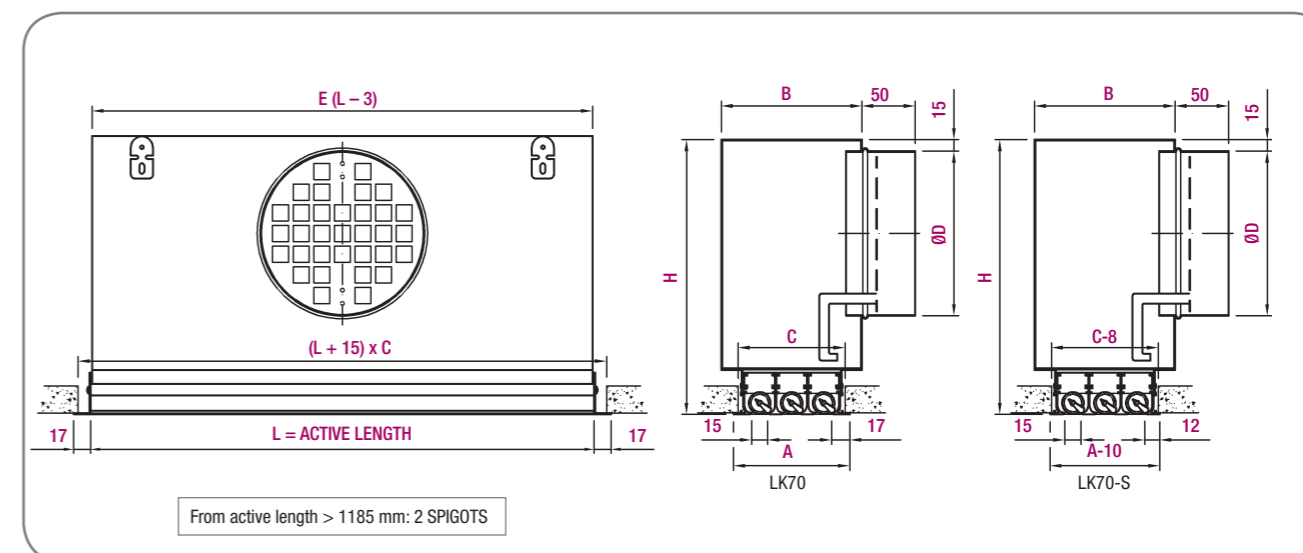

Custom plenums available to suit reduced heights above false ceilings.

Nº of Slots	L	E	Ø D	Nº of Spigots	A	B	C	H
1	600	597	124	1	49	72	41	225
	900	897	124					
	1000	997	124					
	1200	1197	124	2				
	1500	1497	124					
	1800	1797	124					
2	600	597	159	1	79	102	71	275
	900	897	159					
	1000	997	159					
	1200	1197	159	2				
	1500	1497	159					
	1800	1797	159					
3	600	597	199	1	109	132	101	325
	900	897	199					
	1000	997	199					
	1200	1197	199	2				
	1500	1497	199					
	1800	1797	199					
4	600	597	199	1	139	162	131	325
	900	897	199					
	1000	997	199					
	1200	1197	199	2				
	1500	1497	199					
	1800	1797	199					
2000	1997	199						

Unit mm

LK70-C



Catalogue Series LK-70

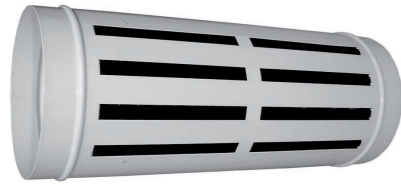

Linear slot diffuser integrated into a circular duct

Product description

Supply linear slot diffuser, model **LK70-C**, suitable for variable and constant volume. Integrated into a circular duct made in galvanised sheet steel, equipped with adjustable blades by means of a wheel mechanism, allowing multiple air patterns. The diffuser is suitable for large airflows at low velocities into the occupied zone. Recommended installation height between 2.5 and 4m.

Incorporates slide type damper.
Interior insulated (optional).

Other models

LK-70-AC. Linear diffuser integrated in curved plate to adapt to circular duct.
Incorporates slide type damper.

General dimensions

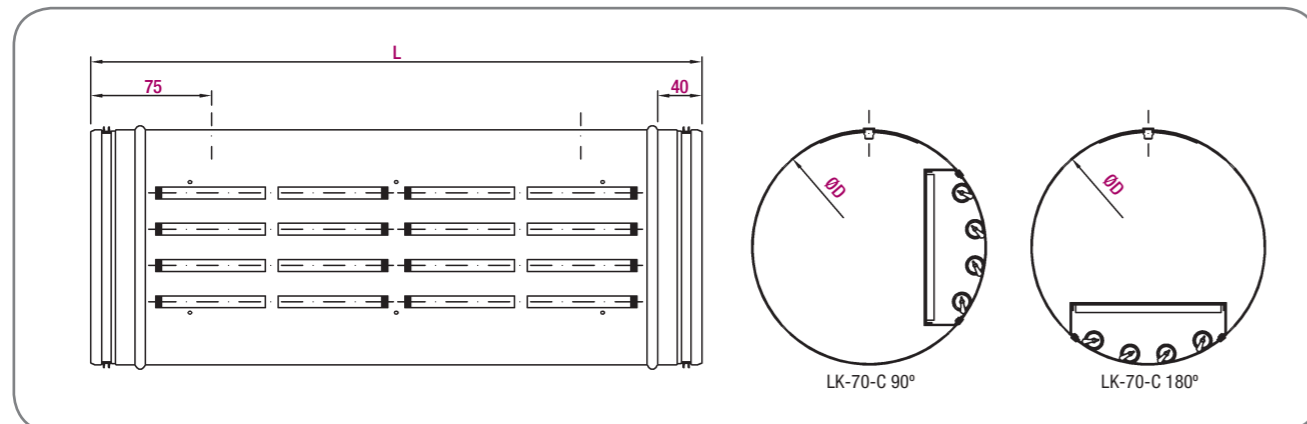

Selection table

(Flow rate per linear metre of diffuser)

Size	Q (m³/h)	L _{wa} [dB(A)]	ΔP _t (Pa)	X (m)
LK70-C 1000-2	160	30	8	3.0
	200	35	12	3.8
	255	40	19	4.8
	320	45	30	6.0
LK70-C 1000-4	260	30	5	3.6
	325	35	9	4.4
	400	40	13	5.5
	490	45	19	6.7
LK70-C 1000-5	330	30	4	3.7
	420	35	7	4.8
	520	40	10	5.9
	625	45	15	7.1
LK70-C 1000-6	400	30	4	4.0
	490	35	6	4.9
	595	40	8	6.2
	750	45	13	7.5
LK70-C 1000-10	450	30	3	4.1
	560	35	5	5.1
	690	40	8	6.4
	870	45	12	7.9
LK70-C 1000-12	500	30	3	3.0
	620	35	5	5.2
	780	40	7	6.6
	960	45	11	8.1
LK70-C 1000-14	570	30	3	4.3
	700	35	4	5.4
	880	40	6	6.8
	1070	45	9	8.2

The Selection Table shows a summary of dimensions. Other sizes available. Consult the Sales Department.



LEGEND

Q (m³/h): Air flow.
L_{wa} [dB(A)]: Sound power level.
ΔP_t (Pa): Total pressure loss.
X (m): Throw for a maximum velocity of 0.25 m/s at the occupied zone
ΔT = 0 °C (isothermal conditions), installed at a height of 3m.

The data presented by meter and duct velocity of Vp < 6 m/s

Dimensions

Ø Nominal	N° of Rows							D
125	2	-	-	-	-	-	-	123
160	2	4	-	-	-	-	-	158
200	2	4	-	-	-	-	-	198
225	2	4	-	-	-	-	-	223
250	2	4	-	-	-	-	-	248
300	2	4	6	-	-	-	-	298
315	2	4	6	-	-	-	-	313
355	2	4	6	8	-	-	-	353
400	2	4	6	8	-	-	-	398
450	2	4	6	8	-	-	-	448
500	2	4	6	8	10	12	14	498
630	2	4	6	8	10	12	14	628
710	2	4	6	8	10	12	14	708
800	2	4	6	8	10	12	14	798
900	2	4	6	8	10	12	14	898

L	500	750	1000	1250	1500	1750	2000
N° of Slots per row	3	4	6	7	8	10	12
N° of Sections	1		2				

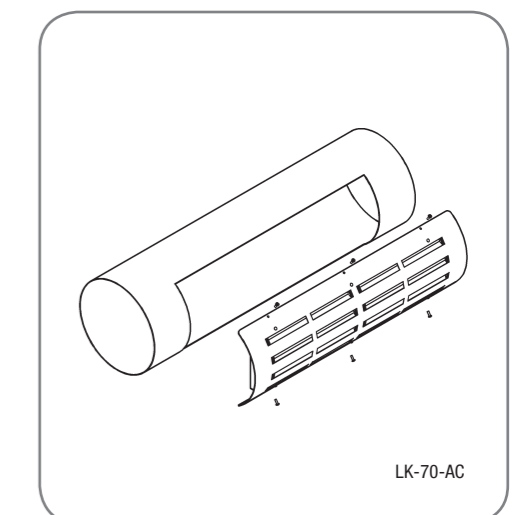

LK-70-AC

Unit mm

S-74-18



Catalogue Series 70.1

Linear Slot Diffuser



Product description

Linear diffuser, KOOLAIR, model **S-74-18**, of _ slots, length _ mm by 18 mm wide with adjustable vanes for horizontal or vertical discharge. Incorporates sliding volume control damper and side connection plenum box made in sheet steel.

Frames made in extruded aluminium. Finished in anodised aluminium or painted in RAL colour upon request. Recommended installation height between 2.5 and 4 m.

Mounting

PFL. Fixed side connection plenum box, without internal insulation made in galvanised sheet steel.

PFL-A. Fixed side connection plenum box, internally insulated made in galvanised sheet steel.

PDL. Removable, by bridges, side connection plenum box, without insulation and made in galvanised sheet steel.

PDL-A. Removable, by bridges, side connection plenum box, internally insulated and made in galvanised sheet steel.

PM. Mounting bridges.

Other models

S-72-18. Linear diffuser without volume control damper.

S-71-18. Linear diffuser without volume control damper and without deflection vanes. For returning air.

S-72 / 74-18-Plate. Linear diffuser integrated in plate of dimensions LxH, to be installed in false ceiling.

S-72-18-18. Linear diffuser without volume control damper, narrow 18-mm outer section.

S-71-18-18. Linear diffuser without volume control damper, narrow 18-mm outer section. For air return.

Note: Possible to form continuous lines (Maximum length per section 2000 mm).

On request, top plenum available insulated/ uninsulated (PFS-A/PFS / PDS-A/PDS).

General dimensions

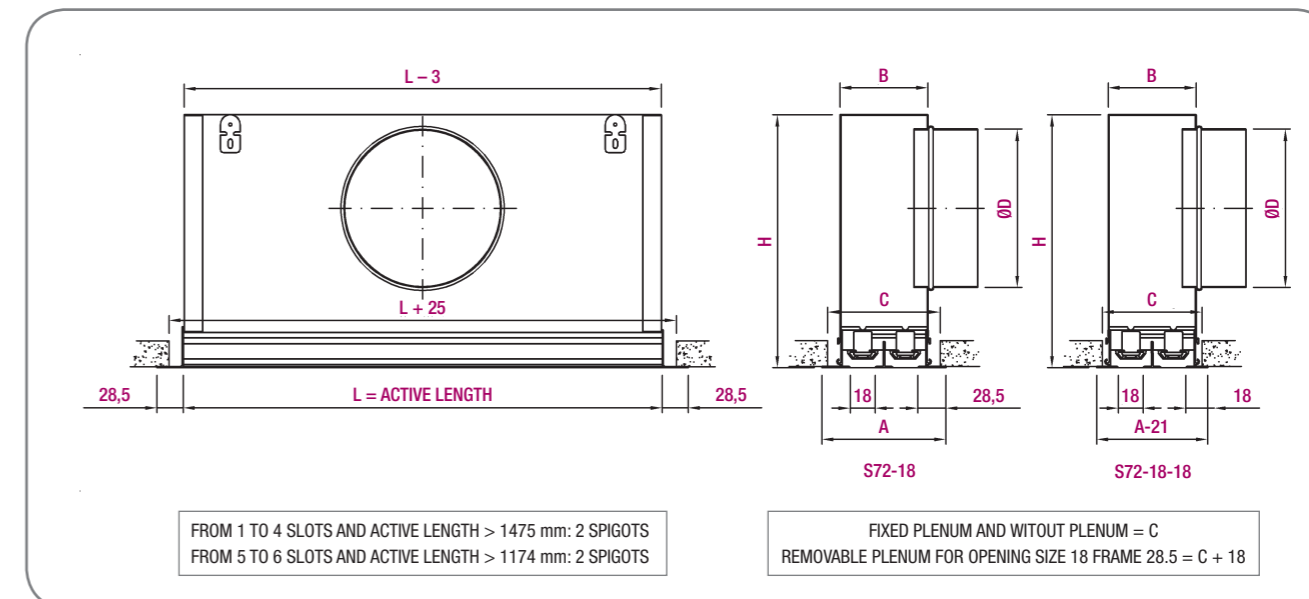

Custom plenums available to suit reduced heights above false ceilings.

No. of Slots	A	B	C	Ø D	H
1	75	40	48	124	225
2	111	76	84	159	275
3	147	112	120	199	325
4	183	148	156	199	325
5	219	184	192	249	375
6	255	220	228	249	375

Unit mm



Selection table

(Flow rate per linear metre of diffuser)

N° of Slots	Dimension	Q (m³/h)	L _{wa} [dB(A)]	ΔP _t (Pa)	X (m)	V _k (m/s)
1	1000	80	24	10	1.5	2.2
		100	32	18	2.0	2.9
		140	40	33	2.6	3.8
2	1000	130	24	10	1.7	1.8
		170	32	18	2.3	2.4
		230	40	32	3.1	3.2
3	1000	170	24	9	1.9	1.6
		230	32	16	2.5	2.1
		300	40	29	3.3	2.8
4	1000	200	24	7	1.9	1.4
		260	32	12	2.5	1.8
		350	40	21	3.3	2.4

LEGEND

Q (m³/h): Air flow.
L_{wa} [dB(A)]: Sound power level.
ΔP_t (Pa): Total pressure loss.
X (m): Throw for a maximum velocity of 0.25 m/s at the occupied zone
ΔT = 0 °C (isothermal conditions), installed at a height of 3m.
V_k (m/s): Effective velocity.

The Selection Table shows a summary of dimensions. Other sizes available. Consult the Sales Department.

S-74-25



Catalogue Series 70.1

Linear Slot Diffusers

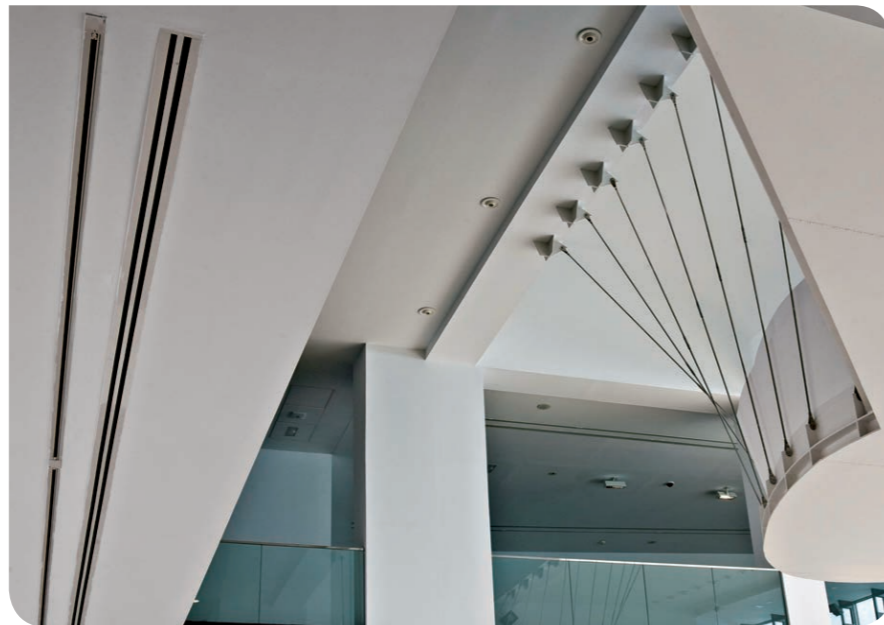

Product description

High capacity linear slot diffuser, KOOLAIR, model **S-74-25**, of _ slots, _ mm long and 25 mm wide with adjustable vanes for horizontal or vertical discharge. Incorporates sliding volume control damper and side connection plenum box made in sheet steel. Frames made in extruded aluminium. Finished in anodised aluminium or painted in RAL colour upon request. Recommended installation height between 2.5 and 4 m.

Mounting

- PFL.** Fixed side connection plenum box, without internal insulation made in galvanised sheet steel.
- PFL-A.** Fixed side connection plenum box, internally insulated made in galvanised sheet steel.
- PDL.** Removable, by bridges, side connection plenum box, without insulation and made in galvanised sheet steel.
- PDL-A.** Removable, by bridges, side connection plenum box, internally insulated and made in galvanised sheet steel.
- PM.** Mounting bridges.

Other models

- S-72-25.** Linear diffuser without volume control damper.
- S-71-25.** Linear diffuser without volume control damper and without deflection vanes. For returning air.
- S-72-25-18.** Linear diffuser without volume control damper, narrow 18-mm outer section.
- S-71-25-18.** Linear diffuser without volume control damper, narrow 18-mm outer section. For returning air.
- S-72-25-PF.** Linear diffuser without volume control damper, with filterholder hinged toward the outside. For returning air.
- S-72 / 74-25-Plate.** Linear diffuser integrated in plate of dimensions LxH, to be installed in false ceiling.

*Note: Possible to form continuous lines (Maximum length per section 2000 mm).
On request, top plenum available insulated/ unisolated (PFS-A/PFS / PDS-A/PDS).*

General dimensions

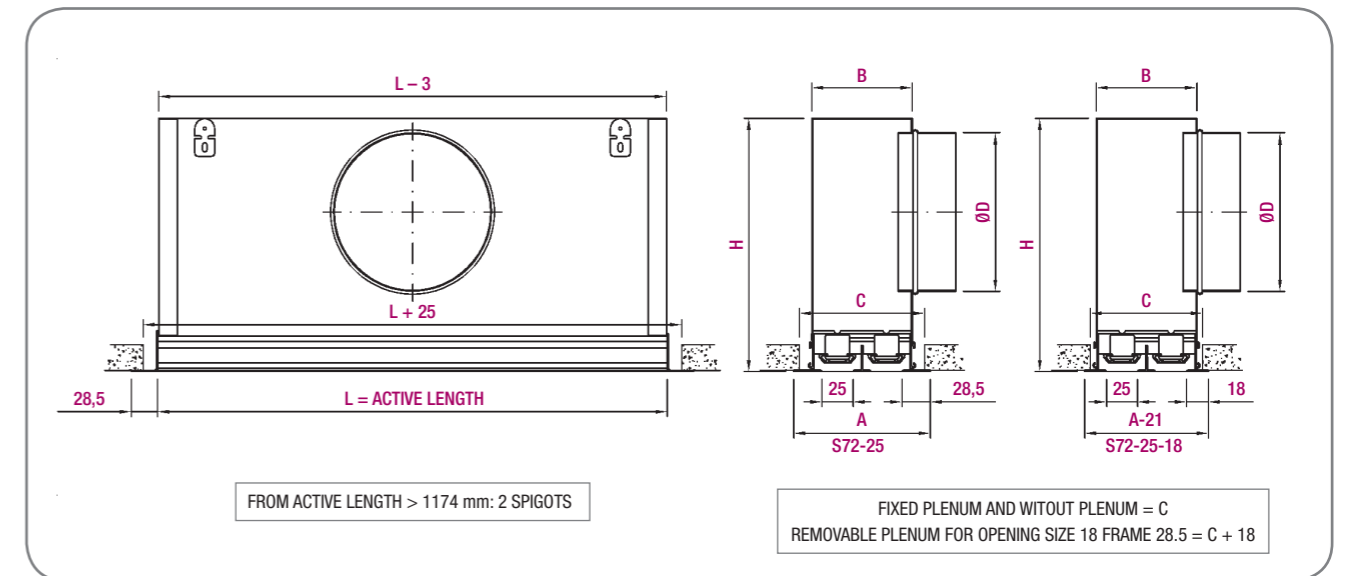

Custom plenums available to suit reduced heights above false ceilings.

N° of Slots	A	B	C	Ø D	H
1	82	47	55	124	225
2	125	90	98	159	275
3	168	133	141	199	325
4	211	176	184	199	325
5	254	219	227	249	375
6	297	262	270	249	375

Unit mm

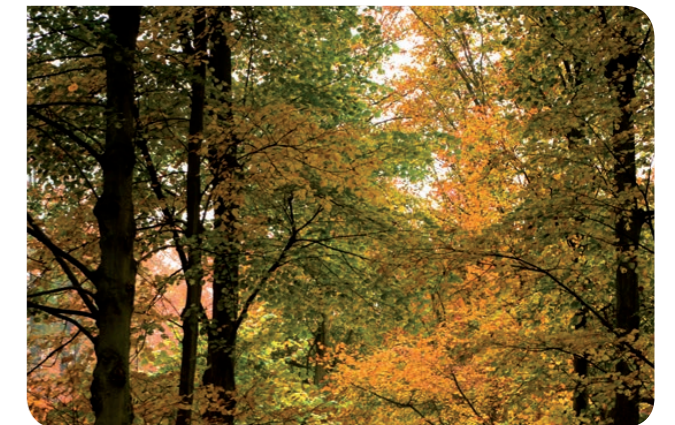

Selection table

(Flow rate per linear metre of diffuser)

N° of Slots	Dimension	Q (m³/h)	L _{wa} [dB(A)]	ΔP _t (Pa)	X (m)	V _k (m/s)
1	1000	80	24	9	1.4	2.0
		110	32	17	1.9	2.8
		160	40	33	2.7	3.9
2	1000	140	24	6	1.6	1.7
		190	32	12	2.3	2.4
3	1000	270	40	23	3.2	3.3
		200	24	6	1.9	1.6
		280	32	11	2.7	2.3
4	1000	390	40	22	3.7	3.2
		260	24	6	2.2	1.6
		360	32	11	3.0	2.2
		500	40	21	4.2	3.1

The Selection Table shows a summary of dimensions. Other sizes available. Consult the Sales Department.

LEGEND

- Q (m³/h): Air flow.
- L_{wa} [dB(A)]: Sound power level.
- ΔP_t (Pa): Total pressure loss.
- X (m): Throw for a maximum velocity of 0.25 m/s at the occupied zone
- ΔT = 0 °C (isothermal conditions), installed at a height of 3 m.
- V_k (m/s): Effective velocity.

S-72-21/18



Catalogue Series 70.1



Linear diffuser

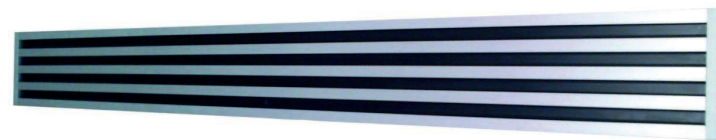

Product description

Linear diffuser with narrow external frame and air passage of 21 mm per slot, Koolair **S-72-21/18** model, of $_$ slots, of length $_$ mm with moveable directional slats for lateral or vertical air discharge. Lateral connection plenum box in galvanized steel sheet; includes volume control damper. Manufactured of extruded aluminium sections. Natural anodized aluminum finish or painted in RAL colour upon request. Recommended installation height of 2.5 to 4 m.

Other models

S-72-21-Plate. Linear diffuser, built into plate of dimensions LxH, for installation in modular drop ceiling.

S-71-21-18. Linear diffuser with narrow external frame and air passage of 21 mm per slot. For returning air.

Mounting

PFL-RL. Fixed side connection plenum box, without internal insulation made in galvanised sheet steel.

PFL-A-RL. Fixed side connection plenum box, internally insulated made in galvanised sheet steel.

PDL-RL. Removable, by bridges, side connection plenum box, without insulation and made in galvanised sheet steel.

PDL-A-RL. Removable, by bridges, side connection plenum box, internally insulated and made in galvanised sheet steel.

PM. Mounting bridge.

Note: Possible to form continuous lines (Maximum length per section 2000 mm).

On request, top plenum available insulated/ uninsulated (PFS-A/PFS / PDS-A/PDS).

General dimensions

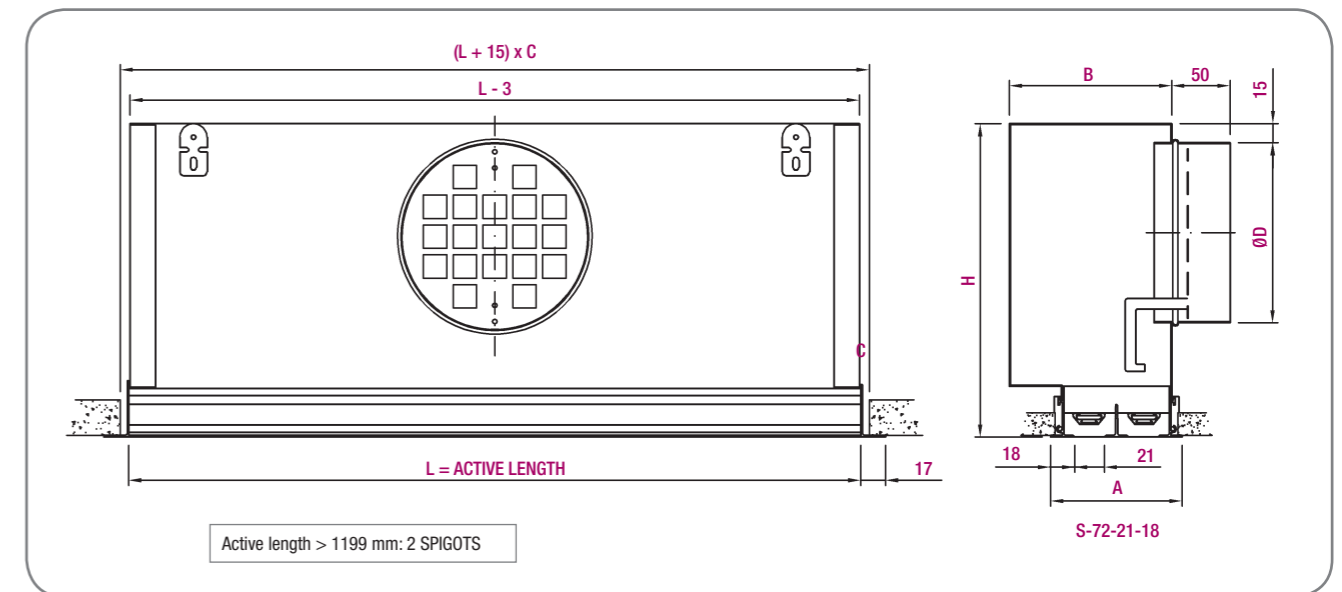

Custom plenums available to suit reduced heights above false ceilings.

N° of Slots	A	B	C	Ø D	H
1	57	80	53	159	275
2	96	119	92	199	325
3	135	158	131	199	325
4	174	197	170	199	325
5	213	236	209	249	375
6	252	275	248	249	375

Unit mm



Selection table

(Flow rate per linear metre of diffuser)

N° of Slots	Dimension	Q (m³/h)	L _{wa} [dB(A)]	ΔP _t (Pa)	X (m)	V _k (m/s)
1	1000	115	24	8	2,4	2,7
		165	32	17	3,5	3,9
		210	40	28	4,4	5,0
2	1000	190	24	6	2,8	2,3
		255	32	10	3,8	3,0
		345	40	19	5,1	4,1
3	1000	275	24	5	2,8	2,2
		370	32	10	3,7	2,9
		485	40	16	4,9	3,9
4	1000	340	24	5	3,6	2,0
		450	32	8	4,7	2,7
		600	40	14	6,3	3,6

The Selection Table shows a summary of dimensions. Other sizes available. Consult the Sales Department.

LEGEND

Q (m³/h): Air flow.
 L_{wa} [dB(A)]: Sound power level.
 ΔP_t (Pa): Total pressure loss.
 X (m): Throw for a maximum velocity of 0.25 m/s at the occupied zone
 ΔT = 0 °C (isothermal conditions), installed at a height of 3 m.
 V_k (m/s): Effective velocity.



Linear Slot Diffusers

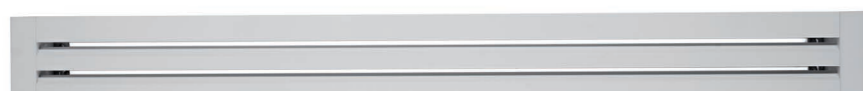

Product description

High capacity linear diffuser, for variable or constant air flow, with fixed directional vanes KOOLAIR, model **KLD**, of _ mm long and _ slots. Incorporates side connection plenum box made in sheet steel, with volume control damper at the entry of it. Frames made in extruded aluminium. Finished in anodised aluminium or painted in RAL colour upon request. Recommended installation height between 2.5 and 4 m.

Other models

KLD-FF. Linear diffuser with filterholder hinged toward the outside. For returning air.

KLD-Plate. Linear diffuser integrated in plate of dimensions LxH, to be installed in false ceiling.

Note: Possible to form continuous lines (Maximum length per section 2000 mm).

On request, top plenum available insulated/ unisolated (PFS-A/PFS / PDS-A/PDS).

Mounting

PFL-RE. Fixed side connection plenum box, without internal insulation made in galvanised sheet steel.

PFL-A-RE. Fixed side connection plenum box, internally insulated made in galvanised sheet steel.

PDL-RE. Removable, by bridges, side connection plenum box, without insulation and made in galvanised sheet steel.

PDL-A-RE. Removable, by bridges, side connection plenum box, internally insulated and made in galvanised sheet steel.

PBL-RE. Removable, by screws, side connection plenum box, without insulation and made in galvanised sheet steel.

PBL-A-RE. Removable, by screws, side connection plenum box, internally insulated and made in galvanised sheet steel.

PM. Mounting bridge.

RFS06. Include a volume control damper.

Note: Connection plenum box can be equipped with VCD on the spigot accessible from the room, available upon request.

General dimensions

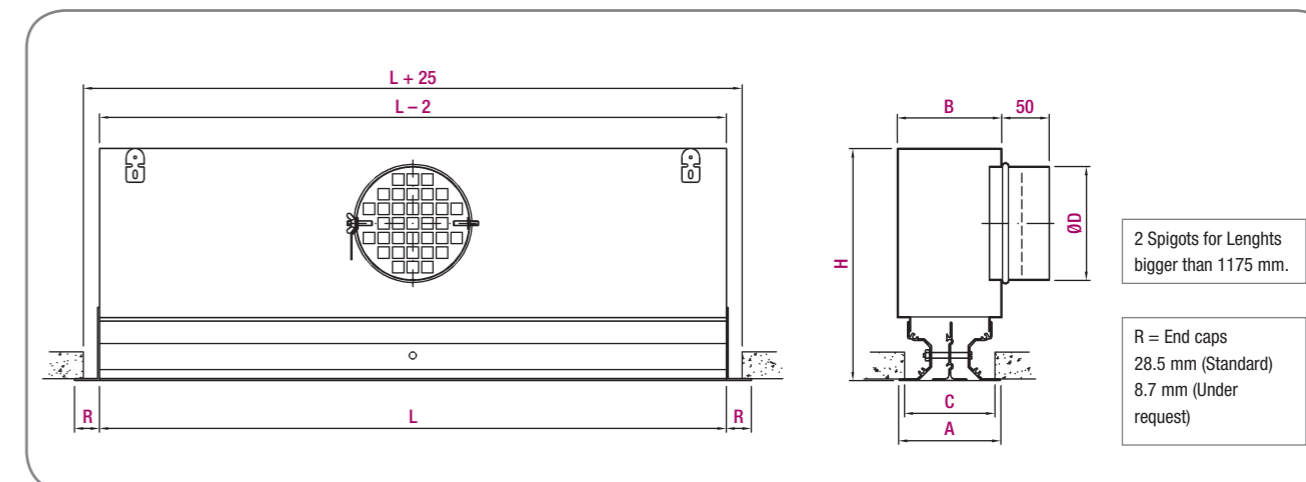

Custom plenums available to suit reduced heights above false ceilings.

N° of Slots	A	B	C	Ø D	H
1:0 / 0:1	60	79	50	159	275
2:0 / 0:2	92	99	82	199	330
3:0 / 0:3	123	131	113	249	330
4:0 / 0:4	155	163	145	249	330
1:1	92	105	82	199	330
1:2 / 2:1	123	137	113	249	330
1:3 / 3:1 / 2:2	155	169	145	249	330

Unit mm

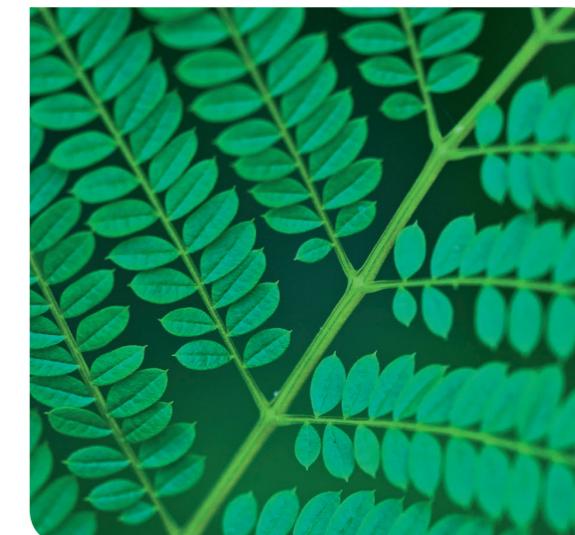

Selection table

(Flow rate per linear metre of diffuser)

N° of Slots	Dimension	Q (m³/h)	L _{wa} [dB(A)]	ΔP _t (Pa)	X (m)	V _k (m/s)
1	1000	140	24	7	2,8	4,3
		190	32	12	3,8	5,7
		250	40	22	5,0	7,7
2	1000	230	24	4	3,2	3,5
		300	32	8	4,3	4,6
3	1000	400	40	14	5,8	6,2
		300	24	3	3,5	3,1
4	1000	400	32	6	4,7	4,1
		550	40	11	6,2	5,5
		360	24	3	3,7	2,8
4	1000	470	32	5	4,9	3,7
		650	40	9	6,6	5,0

The Selection Table shows a summary of dimensions. Other sizes available. Consult the Sales Department.

LEGEND

Q (m³/h): Air flow.
L_{wa} [dB(A)]: Sound power level.
ΔP_t (Pa): Total pressure loss.
X (m): Throw for a maximum velocity of 0.25 m/s at the occupied zone
ΔT = 0 °C (isothermal conditions), installed at a height of 3 m.
V_k (m/s): Effective velocity.



Linear slot diffuser



Product description

High capacity linear ceiling diffuser, for variable or constant air flow, with adjustable vanes to change the direction of the air, with thermal element that closes when the air temperature is over 70° C, KOOLAIR, model **KFD**, _ mm long and _ slots. Incorporates side connection plenum box made in sheet steel, with volume control damper at the entry of it. Frames made in extruded aluminium and deflection blades made in aluminium. Finished in anodised aluminium or painted in RAL colour upon request.

Recommended installation height between 2.5 and 4 m.

Other models

KFD-PLATE LxH. Linear diffuser integrated in plate of dimensions LxH, to be installed in false ceiling.

Note: Possible to form continuous lines (Maximum length per section 2000 mm).

On request, top plenum available insulated/ uninsulated (PFS-A/PFS / PDS-A/PDS).

Mounting

PFL-RE. Fixed side connection plenum box, without internal insulation made in galvanised sheet steel.

PFL-A-RE. Fixed side connection plenum box, internally insulated made in galvanised sheet steel.

PDL-RE. Removable, by bridges, side connection plenum box, without insulation and made in galvanised sheet steel.

PDL-A-RE. Removable, by bridges, side connection plenum box, internally insulated and made in galvanised sheet steel.

PBL-RE. Removable, by screws, side connection plenum box, without insulation and made in galvanised sheet steel.

PBL-A-RE. Removable, by screws, side connection plenum box, internally insulated and made in galvanised sheet steel.

PM. Mounting bridge.

Note: Connection plenum box can be equipped with VCD on the spigot accessible from the room, available upon request.

General dimensions

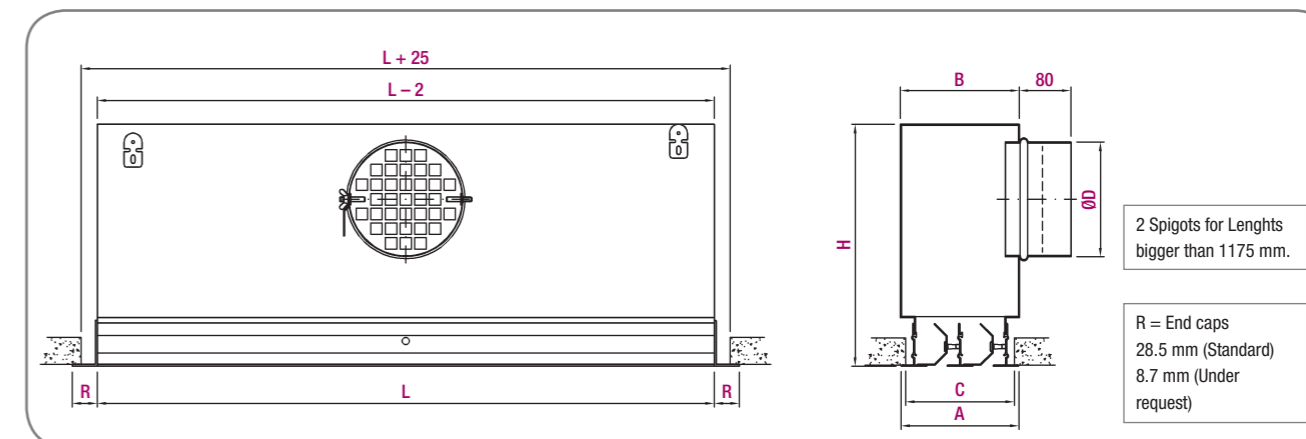

Custom plenums available to suit reduced heights above false ceilings.

N° of Slots	A	B	C	Ø D	H
1	80	83	70	159	275
2	130	134	121	199	330
3	181	185	171	249	330
4	232	236	222	249	330

Unit mm

Selection table

(Flow rate per linear metre of diffuser)

N° of Slots	Dimension	Q (m³/h)	L _{wa} [dB(A)]	ΔP _t (Pa)	X (m)	V _k (m/s)
1	1000	100	24	4	2.1	2.9
		150	32	9	3.2	4.4
		230	40	20	4.8	6.6
2	1000	180	24	3	2.6	2.6
		260	32	7	3.9	3.8
		400	40	16	5.9	5.8
3	1000	240	24	3	3	2.4
		370	32	6	4.5	3.6
		530	40	13	6.7	5.3
4	1000	310	24	3	3.2	2.2
		450	32	5	4.9	3.4
		640	40	12	7.3	5.1

The Selection Table shows a summary of dimensions. Other sizes available. Consult the Sales Department.

LEGEND

Q (m³/h): Air flow.
L_{wa} [dB(A)]: Sound power level.
ΔP_t (Pa): Total pressure loss.
X (m): Throw for a maximum velocity of 0.25 m/s at the occupied zone
ΔT = 0 °C (isothermal conditions), installed at a height of 3 m.
V_k (m/s): Effective velocity.



DF-KR



Catalogue Series DF-KR



4 Way Linear slot diffuser



Product description

Linear diffuser integrated in rectangular plate of 1195x295 mm, with adjustable deflection blades, KOOLAIR, model **DF-KR**, and 1 or 2 slots. Plate and blades made in sheet steel. Finished painted in RAL colour upon request. Incorporates side connection plenum box made in sheet steel, with volume control damper at the entry of it. Finished in anodised aluminium or painted in RAL colour upon request. Recommended installation height between 2.5 and 4 m.

Other models

DF-KR-E. Linear diffuser integrated in plate of 1227x327 mm for plasterboard ceiling.

Note: For accessible volume control damper from the room please ask specifically on order.

Mounting

- PFL-RE.** Side connection plenum box without internal insulation, made in galvanised sheet steel.
- PFL-A-RE.** Side connection plenum box internally insulated, made in galvanised sheet steel.
- PFS-RE.** Top connection plenum box, without internal insulation, made in galvanised sheet steel.
- PFS-A-RE.** Top connection plenum box, internally insulated, made in galvanised sheet steel.

General dimensions

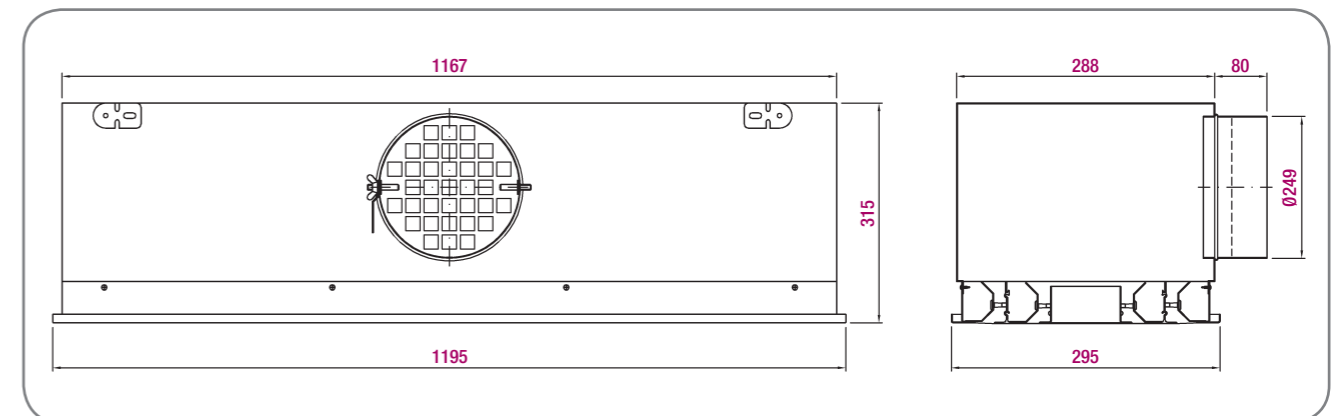

Custom plenums available to suit reduced heights above false ceilings.

Selection table

Size	Q (m ³ /h)	L _{WA} [dB(A)]	ΔP _t (Pa)	X (m)
1	210	24	4	1.9
	300	32	8	2.7
	420	40	16	3.8
2	330	24	5	1.6
	470	32	9	2.3
	670	40	19	3.2

LEGEND

- Q (m³/h): Air flow.
- L_{WA} [dB(A)]: Sound power level.
- ΔP_t (Pa): Total pressure loss.
- X (m): Throw for a maximum velocity of 0.25 m/s at the occupied zone
- ΔT = -10 °C (cold), installed at a height of 2.8 m.
- V_k (m/s): Velocidad efectiva.

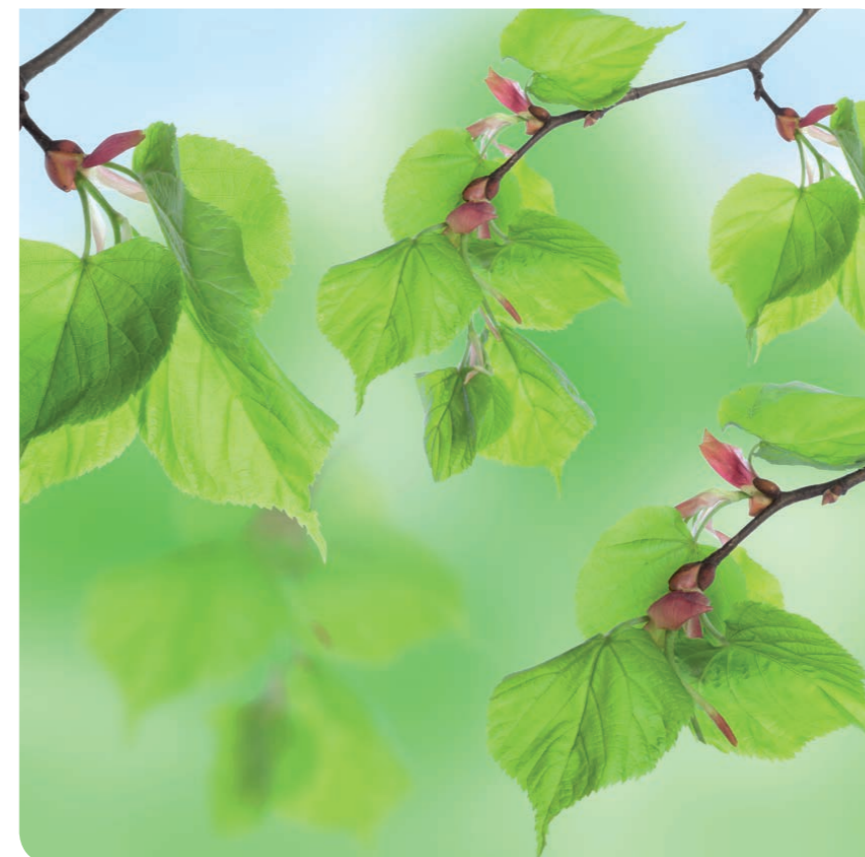

DF-KLT



Hidden linear diffuser integrated in plate



Product description

KOOLAIR double hidden linear diffuser integrated in 1199x299 mm rectangular plate with adjustable deflector blades, model **DF-KLT**, with _ air passage slot. Characterised by the lack of profile on show. Each diffuser has an adjustable blade to discharge air horizontally and vertically with multiple combinations possible. Incorporates a lateral connection plenum complete with regulating damper in the inlet spigot. Diffusers manufactured from aluminium profiles painted matt black (RAL 9005) and sheet steel plate painted in RAL colour of choice. Recommended installation height between 2.5 and 4 m.

Other models

DF-KLT-E. Linear diffuser integrated in 1227x327 plate for suspended drywall ceilings.

Mounting

PFL-RE. Side connection plenum box without internal insulation, made in galvanised sheet steel.
PFL-A-RE. Side connection plenum box internally insulated, made in galvanised sheet steel.
PFS-RE. Top connection plenum box, without internal insulation, made in galvanised sheet steel.
PFS-A-RE. Top connection plenum box, internally insulated, made in galvanised sheet steel.

General dimensions

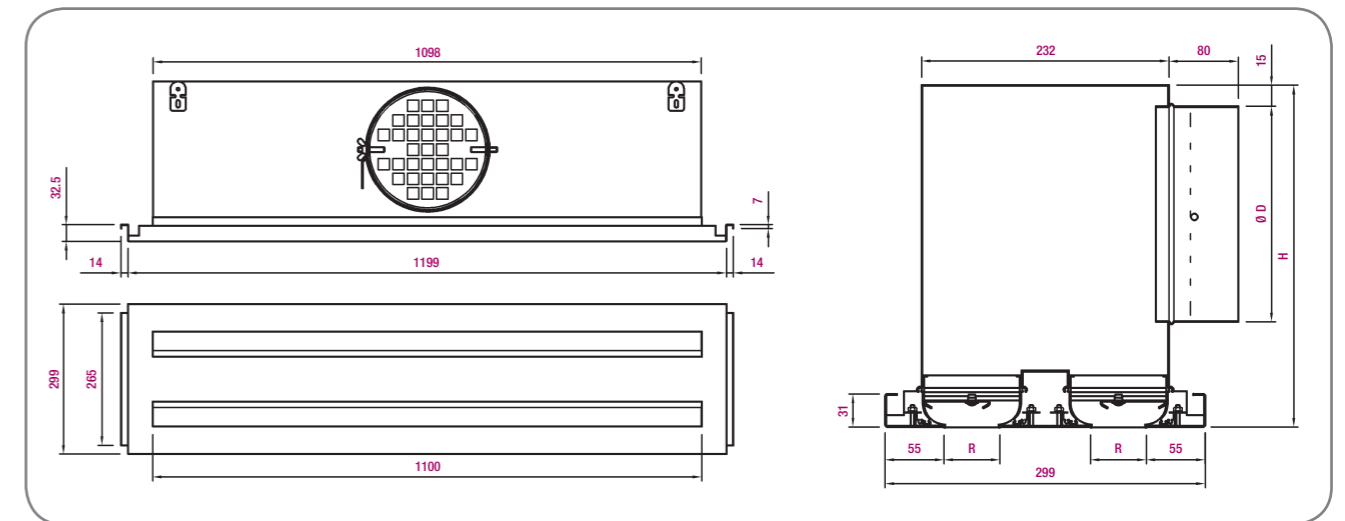

Custom plenums available to suit reduced heights above false ceilings.
 Possibility of manufacturing plates with custom dimensions and ceiling profiles.

Size	Ø D	H
15	159	230
20	199	270
33	249	320
40	249	320
50	314 (oval)	320

Unit mm

Selection table

Size	Q (m³/h)	L _{WA} [dB(A)]	ΔP _t (Pa)	X (m)	V _k (m/s)
15	160	24	6	2,0	2,0
	220	32	10	2,7	2,8
	330	40	22	3,9	4,0
20	210	24	10	2,1	1,8
	300	32	11	3,0	2,5
	420	40	22	4,2	3,5
33	320	24	8	2,4	1,6
	460	32	17	3,5	2,3
	620	40	32	4,7	3,1
40	360	24	6	2,5	1,6
	520	32	12	3,6	2,3
	700	40	21	4,9	3,0
50	440	24	6	2,8	1,7
	600	32	11	3,8	2,3
	800	40	19	5,0	3,1

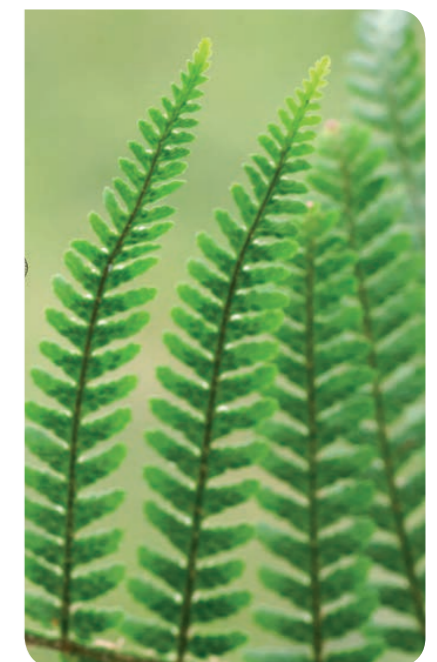

LEGEND

Q (m³/h): Air flow.
 L_{WA} [dB(A)]: Sound power level.
 ΔP_t (Pa): Total pressure loss.
 X (m): Throw for a maximum velocity of 0.25 m/s at the occupied zone
 ΔT = -10 °C (cold), installed at a height of 2.8 m.
 V_k (m/s): Velocidad efectiva.

KLR-NARROW



Linear Slot Diffuser

Product description

KOOLAIR high-induction slot diffuser with a high level of aesthetics, model **KLR-NARROW** with 1 or 2-openings; length L mm, air passage through opening 8 mm, complete with movable directional blades every 100 mm to configure air discharge horizontally, vertically or at an angle. Ideal for installation in suspended ceilings with a slot width equal to or greater than 15 mm due to its small dimensions. Includes sheet steel fixed plenum for lateral connection. Made from extruded aluminium profiles. Anodised aluminium finish or painted in RAL colour (to be defined). Directional blades made of plastic, standard in RAL 9005. Recommended installation height between 2.5 and 4 m.

Note: Possible to form continuous lines (Maximum length per section 2000 mm).

On request, top plenum available insulated/ un-insulated (PFS-A/PFS / PDS-A/PDS).

Other models

KLR-NARROW-CB. With 12,5 mm wide frame.

KLR-NARROW-Curved. Linear slot diffuser forming curved lines.

Mounting

PFL-RL. Fixed side connection plenum box un-insulated.

PFL-A-RL. Fixed side connection plenum box insulated.

PDL-RL. Removable side connection plenum box un-insulated.

PDL-A-RL. Removable side connection plenum box insulated.

PM. Mounting bridges.

General dimensions KLR-NARROW

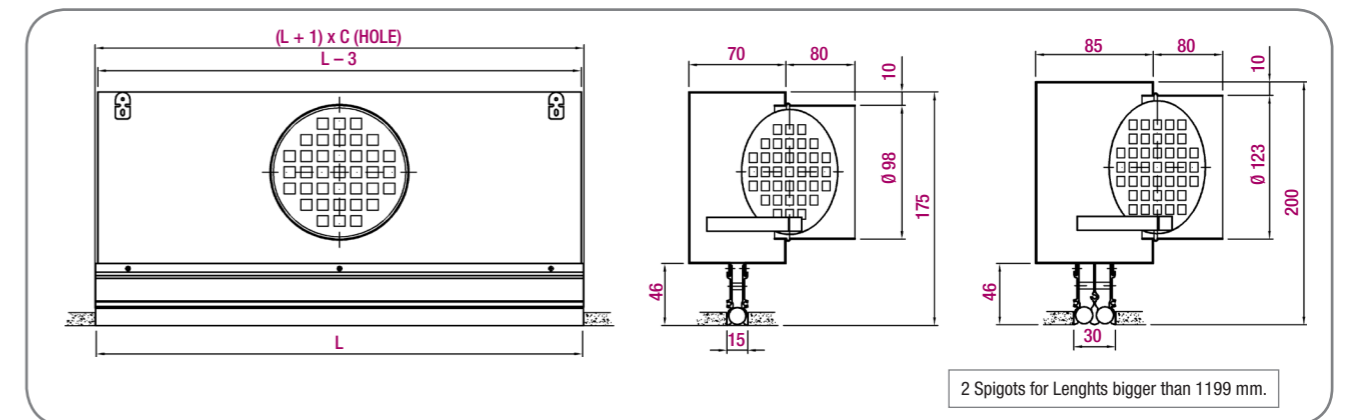

Custom plenums available to suit reduced heights above false ceilings.

No. of slots	C
1	16
2	31

Unit in mm

General dimensions KLR-NARROW-CB

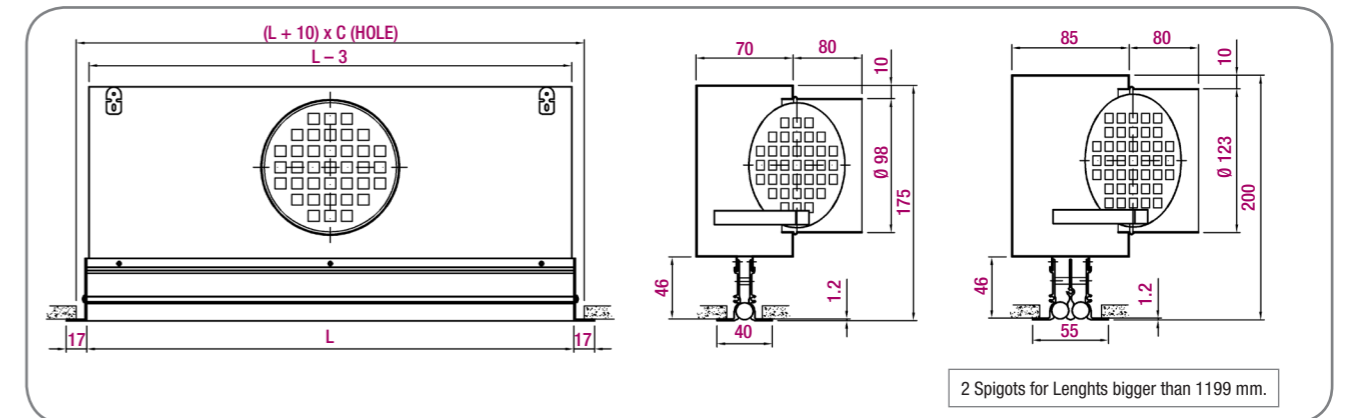

Custom plenums available to suit reduced heights above false ceilings.

No. of slots	C
1	26
2	41

Unit in mm

Selection table

(Flow rate per linear metre of diffuser)

No. of slots	Dimension	Q (m³/h)	L _{WA} [dB(A)]	ΔP _t (Pa)	X (m)	V _k (m/s)
1	1000	45	24	9	1,3	3,2
		65	32	17	1,8	4,5
		90	40	33	2,4	6,3
2	1000	85	24	7	1,7	2,9
		115	32	14	2,3	4,0
		155	40	26	3,1	5,5

The Selection Table shows a summary of dimensions. Other sizes available. Consult the Sales Department.

LEGEND

Q (m³/h): Air flow.
 L_{WA} [dB(A)]: Sound power level.
 ΔP_t (Pa): Total pressure loss.
 X (m): Throw for a maximum velocity of 0.25 m/s at the occupied zone.
 ΔT = -10 °C (cold), installed at 2.8 m of height.
 V_k (m/s): Effective velocity.



Linear Slot Diffuser



Product description

Linear slot diffuser, KOOLAIR, model **KLR**, of _ slots, length _mm with 15 or 24 mm wide air passage adjustable vanes by rotation for horizontal, inclined or vertical discharge. Incorporates side connection plenum box made in sheet steel. Frames made in extruded aluminium. Finished in anodised aluminium or painted in RAL colour upon request. Adjustable vanes in plastic, standard color RAL 9005. Recommended installation height between 2.5 and 4 m.

Other models

KLR-15/24-Curved. Linear slot diffuser 15/24 mm forming curved lines.

Mounting

- PFL-RL.** Fixed side connection plenum box uninsulated.
- PFL-A-RL.** Fixed side connection plenum box insulated.
- PDL-RL.** Removable side connection plenum box uninsulated.
- PDL-A-RL.** Removable side connection plenum box insulated.
- PM.** Mounting bridges.

Note: Possible to form continuous lines (Maximum length per section 2000 mm).

On request, top plenum available insulated/ uninsulated (PFS-A/PFS / PDS-A/PDS).

General dimensions (KLR-15)

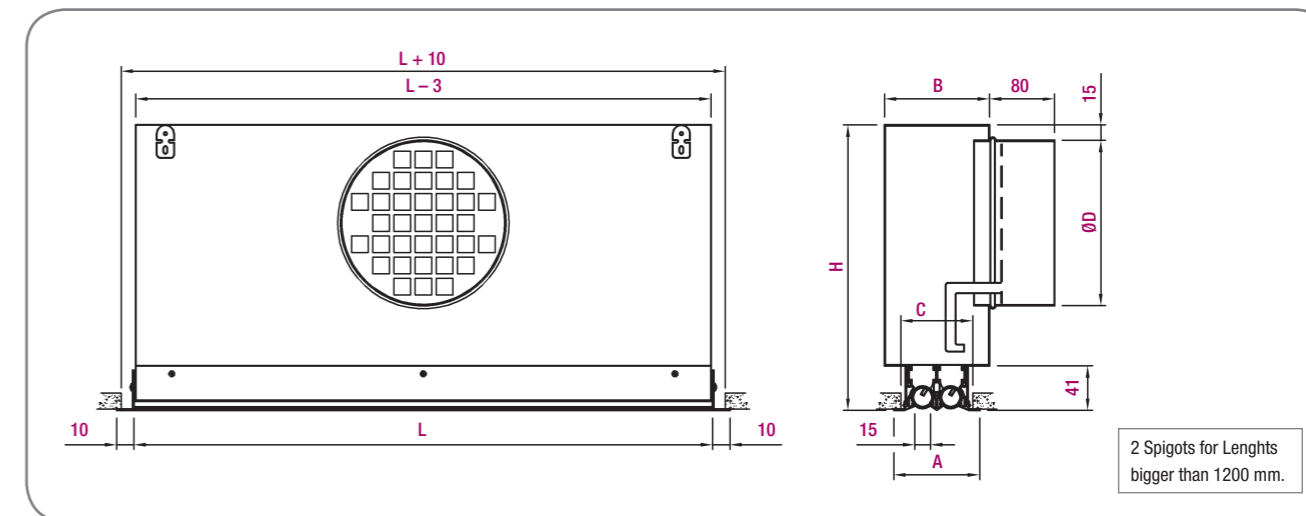

Custom plenums available to suit reduced heights above false ceilings.

KLR-15 fixed plenum

N° of Slots	A	B	C	Ø D	H
1	55	71	45	124	225
2	81,5	97,5	71,5	159	275
3	108	124	98	199	325
4	135	151	125	199	325

Unit mm



Selection table KLR-15 (Flow rate per linear metre of diffuser)

N° of Slots	Dimension	Q (m³/h)	L _{wa} [dB(A)]	ΔP _t (Pa)	X (m)	V _k (m/s)
1	1000	66	24	8	3.5	2.8
		90	32	14	4.8	3.9
		122	40	26	6.5	5.2
2	1000	108	24	5	4.1	2.3
		147	32	10	5.6	3.2
		200	40	18	7.6	4.3
3	1000	145	24	4	4.5	2.1
		200	32	8	6.2	2.9
		275	40	15	8.5	3.9
4	1000	177	24	3	4.7	1.9
		250	32	7	6.7	2.7
		328	40	12	8.8	3.5

LEGEND

- Q (m³/h): Air flow.
- L_{wa} [dB(A)]: Sound power level.
- ΔP_t (Pa): Total pressure loss.
- X (m): Throw for a maximum velocity of 0.25 m/s at the occupied zone.
- ΔT = 0 °C (isothermal conditions), installed at 2.8 m of height.
- V_k (m/s): Effective velocity.

The Selection Table shows a summary of dimensions. Other sizes available. Consult the Sales Department.

KLR

General dimensions (KLR-24)

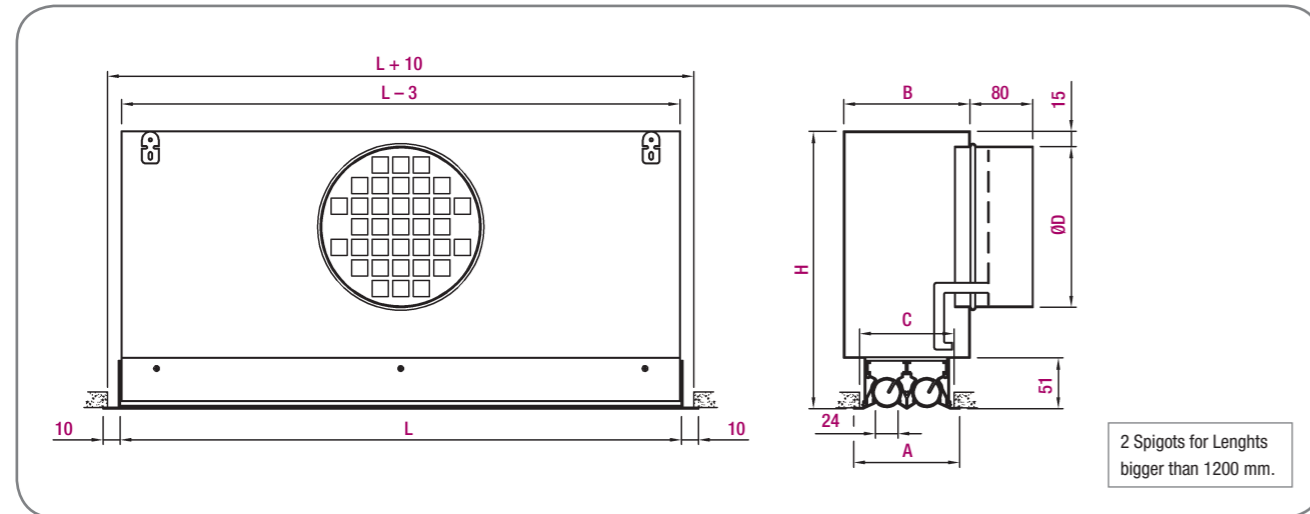

Custom plenums available to suit reduced heights above false ceilings.

KLR-24 removable plenum

N° of Slots	A	B	C	Ø D	H
1	70	86	60	124	225
2	112.5	128.5	102.5	159	275
3	155	171	145	199	325
4	197.5	213.5	187.5	199	325

Unit mm



Diffuser KLR-Curved

Selection table KLR-24

(Flow rate per linear metre of diffuser)

N° of Slots	Dimension	Q (m³/h)	L _{wa} [dB(A)]	ΔP _t (Pa)	X (m)	V _k (m/s)
1	1000	85	24	9	3,6	2,8
		115	32	16	4,9	3,9
		160	40	31	6,8	5,4
2	1000	150	24	7	4,5	2,5
		210	32	14	6,3	3,5
		290	40	26	8,7	4,9
3	1000	250	24	8	6,1	2,8
		350	32	17	8,6	3,9
		480	40	31	11,8	5,4
4	1000	290	24	6	6,2	2,4
		400	32	12	8,5	3,3
		560	40	24	11,9	4,7

The Selection Table shows a summary of dimensions. Other sizes available. Consult the Sales Department.

LEGEND

Q (m³/h): Air flow.

L_{wa} [dB(A)]: Sound power level.

ΔP_t (Pa): Total pressure loss.

X (m): Throw for a maximum velocity of 0.25 m/s at the occupied zone.

ΔT = 0 °C (isothermal conditions), installed at 2.8 m of height.

V_k (m/s): Effective velocity.



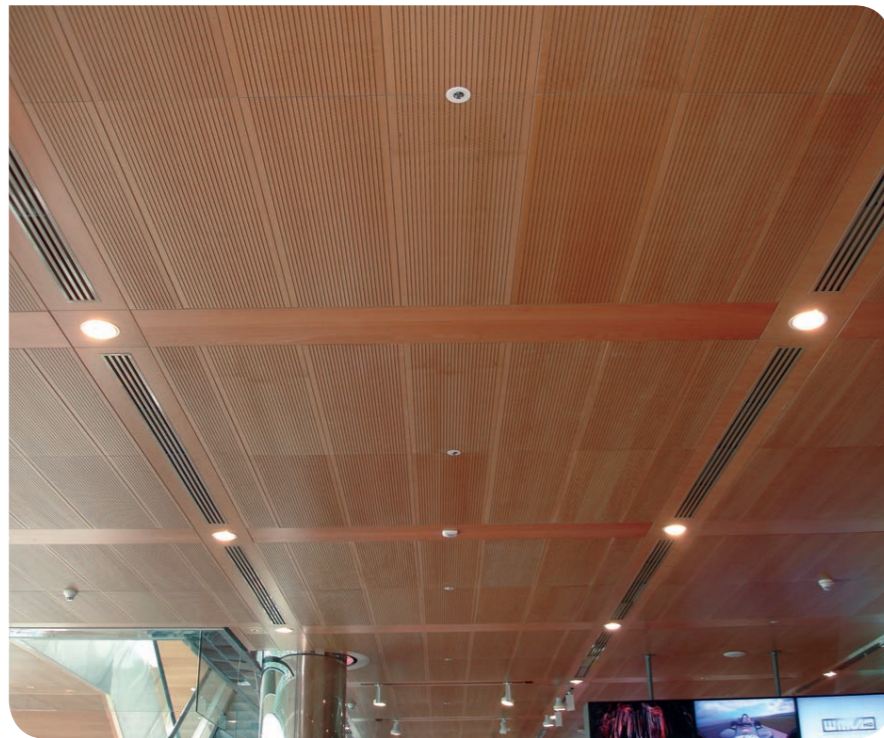

Linear Slot Diffuser



Product description

Linear slot diffuser, KOOLAIR, model **HIDE**, of _ slots, length _mm, 21 mm width slot with no external frames providing it a high aesthetic level. Its directional blades allows directing the airflow from 0° to 180°.

Incorporates connection plenum box made in steel sheet with regulation damper in the spigot.

Finished in anodised aluminium or painted in RAL colour upon request. The directional blades are in black.

Recommended installation height between 2.5 and 4 m.

Note: Possible to form continuous lines (Maximum length per section 2000 mm).

Other models

R-1,5. 1,5 mm end cap.

R-8,7. 8,7 mm end cap.

R-17. 17 mm end cap.

Mounting

PFL-RL. Fixed side connection plenum box uninsulated. With damper.

PFL-A-RL. Fixed side connection plenum box, insulated. With damper.

PFS-RL. Fixed top connection plenum box uninsulated. With damper.

PFS-A-RL. Fixed top connection plenum box, insulated. With damper.

ESD. Supports for hanging diffuser.

General dimensions

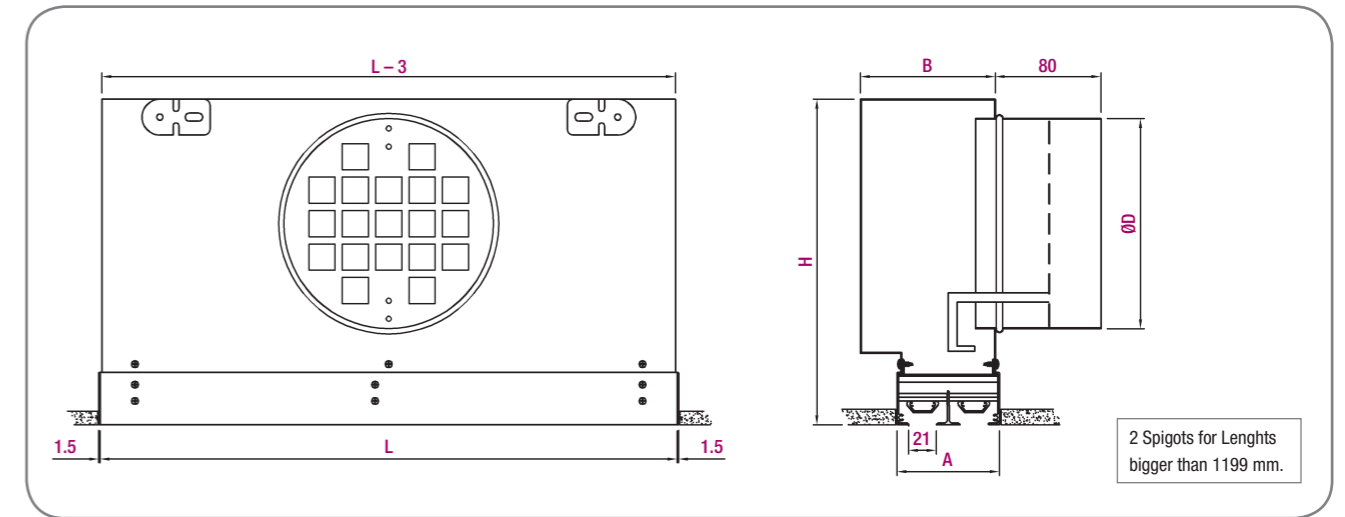

Custom plenums available to suit reduced heights above false ceilings.

HIDE (Side connection plenum box)

N° of Slots	A	B	Ø D	H
1	38.5	80	124	211
2	77.5	119	159	246
3	116.5	158	199	286
4	155.5	197	199	286

Unit mm

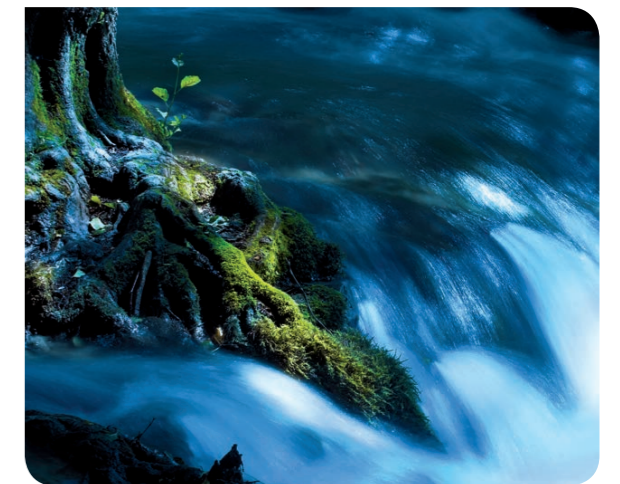

Selection table

(Flow rate per linear metre of diffuser)

N° of Slots	Dimension	Q (m³/h)	L _{wa} [dB(A)]	ΔP _t (Pa)	X (m)	V _k (m/s)
1	1000	110	24	8	1.9	2.6
		150	32	14	2.6	3.6
		200	40	25	3.5	4.8
2	1000	175	24	5	2.2	2.1
		250	32	10	3.1	3.0
3	1000	320	40	16	4.0	3.8
		240	24	4	2.4	1.9
4	1000	320	32	7	3.2	2.5
		425	40	13	4.3	3.4
		275	24	3	2.4	1.6
4	1000	360	32	5	3.2	2.2
		500	40	10	4.4	3.0

The Selection Table shows a summary of dimensions. Other sizes available. Consult the Sales Department.

LEGEND

Q (m³/h): Air flow.
 L_{wa} [dB(A)]: Sound power level.
 ΔP_t (Pa): Total pressure loss.
 X (m): Throw for a maximum velocity of 0.25 m/s at the occupied zone
 ΔT = 0 °C (isothermal conditions), installed at 2.8 m of height.
 V_k (m/s): Effective velocity.

DF-LIT-E-3.0



Invisible linear slot diffuser

Product description

Invisible linear slot diffuser with good aesthetic, KOOLAIR, model **DF-LIT-E-3.0**, length $_$ mm and slot $_$ mm for air passage. It is characterized by the absence of visible profiles. With an adjustable blade that allows both vertical and horizontal discharge. Incorporates side plenum box with manual control damper accessible from room.

Finished in aluminium painted in matt black (RAL 9005).

Recommended installation height between 2.5 and 4 m.

Note: Possible to form continuous lines (Maximum length per section 2000 mm).

Other models

CROSS-DF-LIT-E-3.0. Decorative invisible linear diffuser in the shape of a cross at 90° devised to form a continuous line with other active or decorative sections.

T-DF-LIT-E-3.0. Decorative invisible linear diffuser in the shape of a "T" at 90° devised to form a continuous line with other active or decorative sections.

MITRED-CORNER-DF-LIT-E-3.0. Decorative invisible linear diffuser in the shape of an elbow at 90° devised to form a continuous line with other active or decorative sections.

Mounting

PFL-RL. Fixed side connection plenum box uninsulated.

PFL-A-RL. Fixed side connection plenum box, insulated.

ESD. Supports for hanging diffuser.

RFS06. Sliding damper used without plenum. Incorporates mounting brackets in order to hold the diffuser from the ceiling.

Note: On request, top plenum available insulated/uninsulated (PFS-A/PFS).

General dimensions

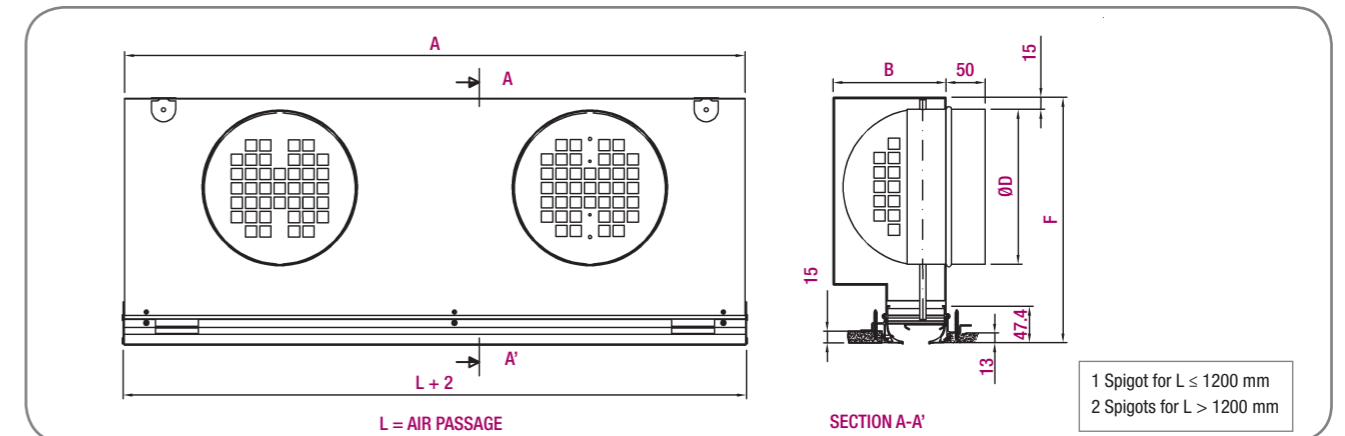

Custom plenums available to suit reduced heights above false ceilings.

HOLE	NOMINAL	L	A	B	Ø D	F	No. INLETS
15	600	600	598	127	125	240	1
	1000	1000	998				
	1200	1200	1198				
	1500	1500	1498				
	1800	1800	1798				
20	600	600	598	132	160	275	1
	1000	1000	998				
	1200	1200	1198				
	1500	1500	1498				
	1800	1800	1798				
33	600	600	598	145	160	275	1
	1000	1000	998				
	1200	1200	1198				
	1500	1500	1498				
	1800	1800	1798				
40	600	600	598	152	200	315	1
	1000	1000	998				
	1200	1200	1198				
	1500	1500	1498				
	1800	1800	1798				
50	600	600	598	162	200	315	1
	1000	1000	998				
	1200	1200	1198				
	1500	1500	1498				
	1800	1800	1798				
	2000	2000	1998				2

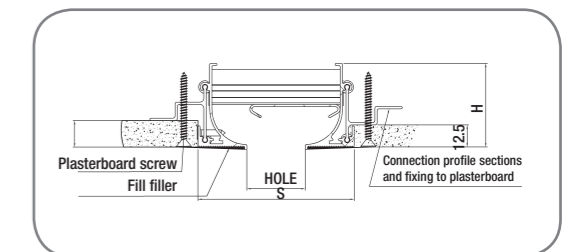

HOLE	S	H
15	70,5	47,4
20	75,5	47,4
33	88,5	47,4
40	99,5	47,4
50	105,5	47,4

Unit mm

Selection table

(Flow rate per linear metre of diffuser)

Slots width	Dimension	Q (m³/h)	L _{WA} [dB(A)]	ΔP _t (Pa)	X (m)	V _k (m/s)
15	1000	85	24	7	2,2	2,3
		120	32	15	3,0	3,3
		165	40	29	4,1	4,6
20	1000	115	24	8	2,4	2,1
		165	32	17	3,4	3,1
		225	40	31	4,7	4,2
33	1000	170	24	12	2,7	1,9
		240	32	23	3,8	2,7
		335	40	45	5,2	3,7
40	1000	195	24	8	2,8	1,9
		270	32	15	3,9	2,6
		375	40	30	5,5	3,6
50	1000	230	24	7	3,0	2,0
		315	32	14	4,2	2,7
		450	40	28	5,9	3,6

LEGEND

- Q (m³/h): Air flow.
- L_{WA} [dB(A)]: Sound power level.
- ΔP_t (Pa): Total pressure loss.
- X (m): Throw for a maximum velocity of 0.25 m/s at the occupied zone
- ΔT = 0 °C (isothermal conditions), installed at 2.8 m of height.
- V_k (m/s): Effective velocity.

The Selection Table shows a summary of dimensions. Other sizes available. Consult the Sales Department.

Floor diffuser

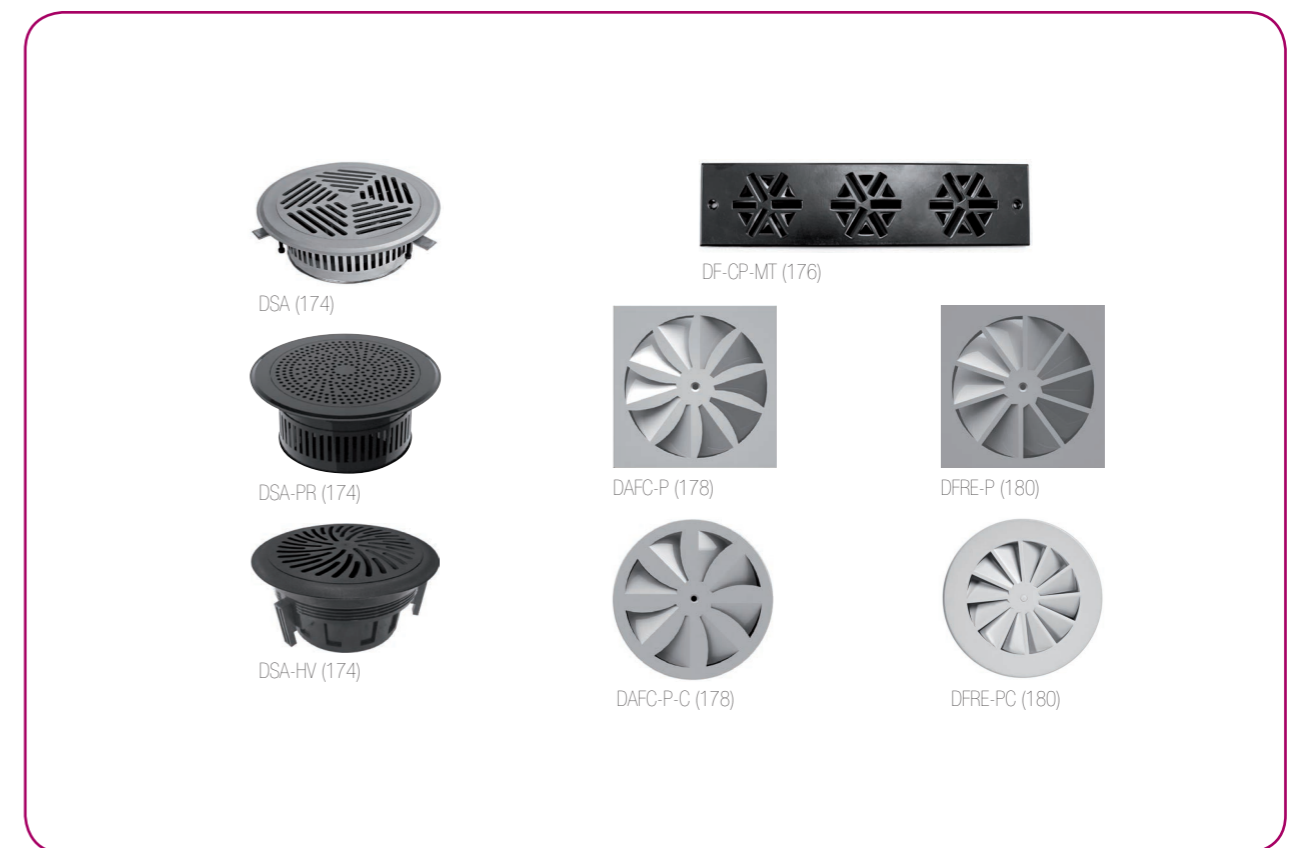

IMG Media - Stockley Park
(London - United Kingdom)

Linear diffusers S-74 with plenum.

DSA



Catalogue Series Floor



DSA



DSA-PR



DSA-HV



Floor diffuser

Product description

Floor circular diffuser with swirl function, KOOLAIR, **DSA** model, dimension \varnothing . In its interior it incorporates a swirl diffuser, and a dirt trap. Punched plate and decorative ring made in aluminium. Finished in aluminium or painted in RAL colour upon request.

The units have been tested and meet EN13264:2001 requirements. Study conducted using an area of 30x30 mm² in the middle of the diffuser.

Model	Size	Load (KN)
DSA/DSA-PR	Ø 150	2.5
	Ø 200	2.25
DSA-HV	Ø 200	2

Unit mm

Other models

DSA-PR. Floor circular diffuser, with swirl function, and frontal perforated plate made in steel sheet of 3 mm thick. More robust than the standard model.

DSA-HV. Floor circular diffuser, with swirl function, frontal plate and dirt trap made of ABS material. High induction model for large airflows.

Painted in black RAL-9005 or gray RAL-9006.

Mounting

Without indication, fixed by hanging brackets.

PF. Connection plenum box made of galvanised steel sheet. Please consult us for design details.

General dimensions

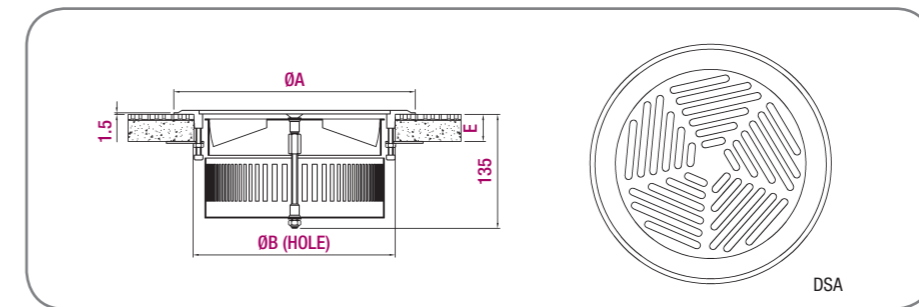

Size	ØA	ØB	E (min)	E (max)
150	190	150	14	50
200	240	200	19	50

Unit mm

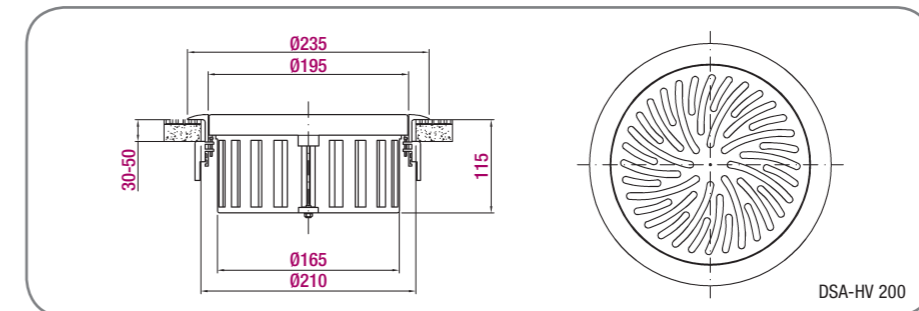

Selection table (DSA)

Size	Q (m³/h)	L _{WA} [dB(A)]	ΔP _{est} (Pa)	h _{0,25} (m)			V _K (m/s)
				ΔT= -4°	ΔT= -6°	ΔT= -8°	
150	32	20	7	0.9	0.7	0.6	1.8
	41	26	11	1.1	1.0	0.8	2.3
	54	32	19	1.4	1.3	1.1	3.0
200	60	20	5	0.8	0.7	0.6	1.8
	78	26	8	1.0	0.9	0.8	2.3
	98	32	13	1.3	1.1	1.0	2.9

Selection table (DSA-PR)

Size	Q (m³/h)	L _{WA} [dB(A)]	ΔP _{est} (Pa)	h _{0,25} (m)			V _K (m/s)
				ΔT= -4°	ΔT= -6°	ΔT= -8°	
150	26	20	9	0.9	0.8	0.7	2.1
	33	26	17	1.2	1.1	0.9	2.9
	42	32	28	1.5	1.3	1.2	3.6
200	49	20	8	0.9	0.8	0.7	2.2
	62	26	12	1.0	0.9	0.8	2.8
	80	32	21	1.5	1.3	1.1	3.6

Selection table (DSA-HV)

Size	Q (m³/h)	L _{WA} [dB(A)]	ΔP _{est} (Pa)	h _{0,25} (m)			V _K (m/s)
				ΔT= -4°	ΔT= -6°	ΔT= -8°	
200	100	20	9	0.7	0.6	0.5	1.8
	140	26	13	1.1	1.0	0.9	2.2
	180	32	25	1.3	1.2	1.1	2.9



LEGEND

Q (m³/h): Air flow.
 L_{WA} [dB(A)]: Sound power level.
 ΔP_i (Pa): Pressure drop.
 ΔP_{est} (Pa): Static pressure.
 ΔT (°C): Difference between the air supplied temperature and the ambient.
 h_{0,25} (m): Vertical throw for a maximum air velocity of 0.25 m/s, and a determined (ΔT).
 V_K (m/s): Effective velocity.

DF-CP-MT



Catalogue Series Floor



Step micro-swirl diffuser



Product description

Multiple rotational diffuser for riser, KOOLAIR, model **DF-CP-MT**, of dimensions $L \times H$, formed by a frontal rectangular plate that incorporates n swirl micro-diffusers.

Made in steel sheet. Finished painted in RAL colour upon request.

Mounting

Without indication, mounted directly by screws.

PF. Connection plenum box made of galvanised steel sheet. Please consult us for design details.



General dimensions

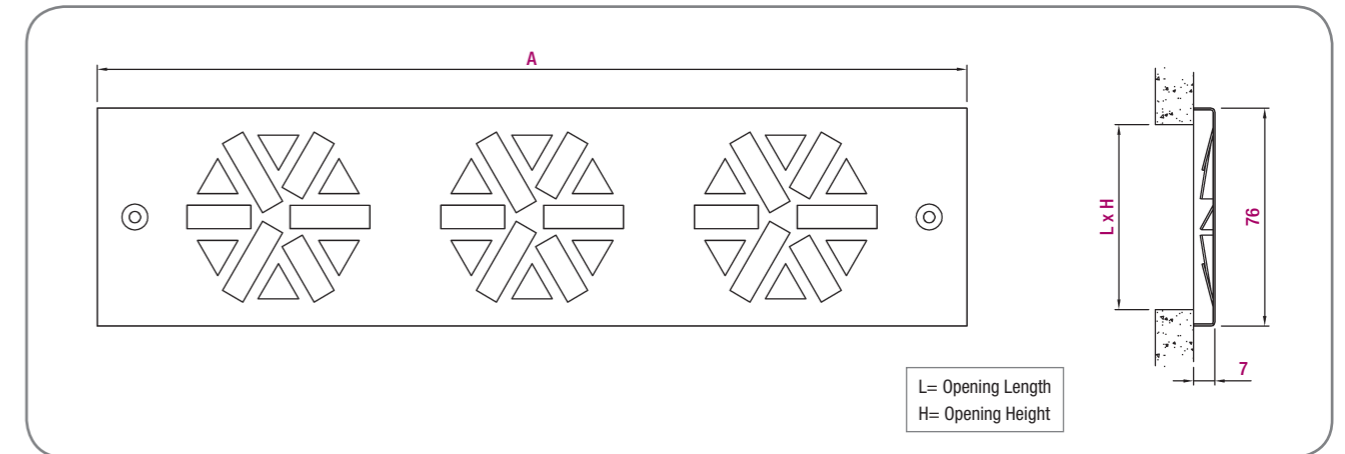

Model	L x H	A
2	165 x 65	212.5
3	250 x 65	300
4	340 x 65	387.5
5	425 x 65	475
6	450 x 65	500

Unit mm



Selection table

Diffusers	Nominal dimension	Q (m³/h)	L _{wa} [dB(A)]	ΔP _t (Pa)	V _x (m/s)
2	165 x 65	22	20	10	0.14
		27	26	16	0.17
		35	32	26	0.23
3	250 x 65	31	20	9	0.16
		39	26	15	0.21
4	340 x 65	49	32	23	0.26
		39	20	8	0.18
5	425 x 65	49	26	13	0.22
		63	32	21	0.29
6	450 x 65	47	20	8	0.19
		59	26	12	0.24
6	450 x 65	75	32	19	0.31
		54	20	7	0.20
6	450 x 65	69	26	11	0.26
		88	32	18	0.33

LEGEND

Q (m³/h): Air flow par plaque.
L_{wa} [dB(A)]: Sound power level.
ΔP_t (Pa): Total pressure loss.
V_x (m/s): Maximum velocity of the air stream at 0.70 m from the diffuser.

DAFC-P



Catalogue Diffuser DAFC-P



DAFC-P

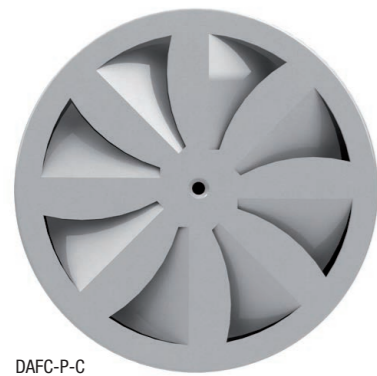

DAFC-P-C



Step swirl diffusers

Product description

Swirl diffuser for riser, KOOLAIR, model **DAFC-P**, of size _,integrated in a plate of _x_. Mounting bridge incorporated. Made in steel sheet. Finished painted in RAL colour upon request.

Other models

DAFC-P-C. Swirl diffuser for riser integrated in a circular plate, size_,diameter Ø _.

Mounting

PM. Mounted directly by mounting bridge.
PD. Connection plenum box made of galvanised steel sheet. Please consult us for design details.

General dimensions

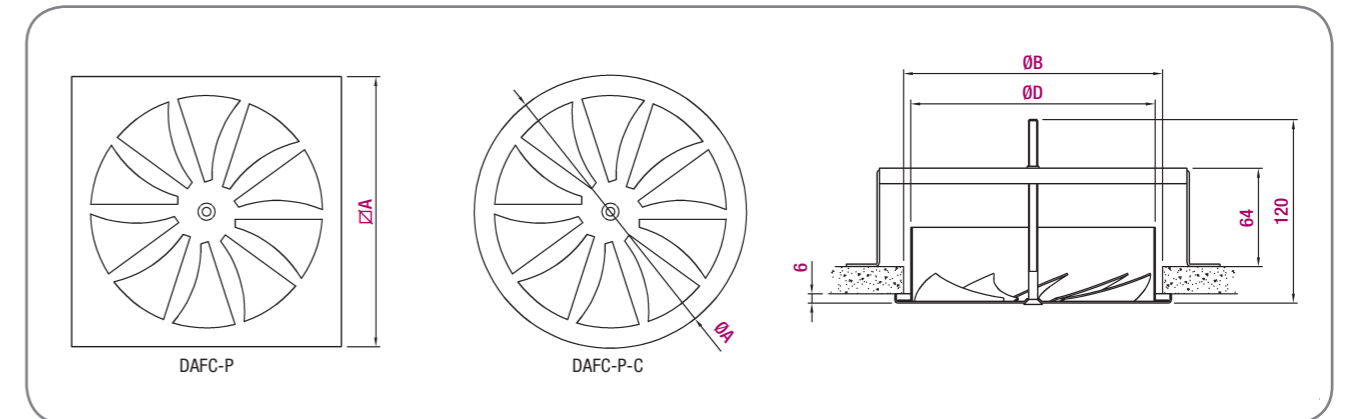

Nominal	A	B	D
125	150	135	124
160	Ø182 / Ø180	170	159

Unit mm

Selection table

Size	Q (m³/h)	L _{wa} [dB(A)]	ΔP _t (Pa)	V _x (m/s)
125	35	20	8	0.14
	45	26	13	0.18
	60	32	24	0.24
160	50	20	6	0.18
	65	26	11	0.23
	85	32	19	0.30

LEGEND

Q (m³/h): Air flow par Diffuser.
 ΔP_t (Pa): Total pressure loss.
 L_{wa} [dB(A)]: Sound power level.
 V_x (m/s): Maximum velocity of the air stream at 0.70 m from the diffuser.



DFRE-P



Catalogue Diffuser DFRE-P

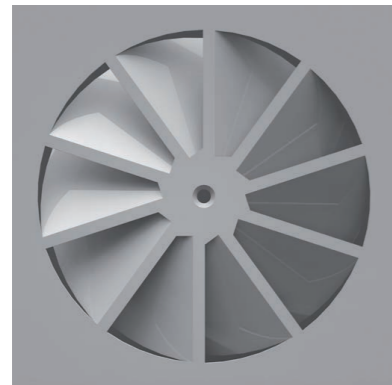

DFRE-P



DFRE-P-C

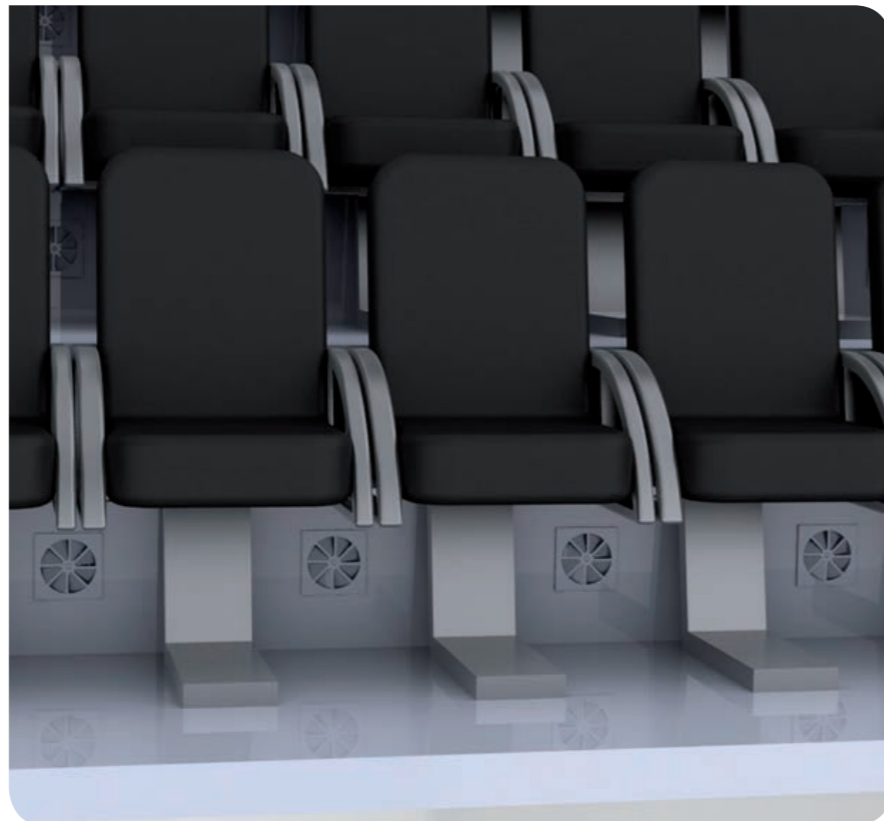

Step swirl diffusers

Product description

Swirl diffuser for riser, KOOLAIR, model **DFRE-P**, of size __, integrated in a plate of __x__. Mounting bridge incorporated. Made in steel sheet. Finished painted in RAL colour upon request.

Other models

DFRE-P-C. Swirl diffuser for riser integrated in a circular plate, size __, diameter Ø __.

Mounting

PM. Mounted directly by mounting bridge.

PD. Connection plenum box made of galvanised steel sheet. Please consult us for design details.

General dimensions

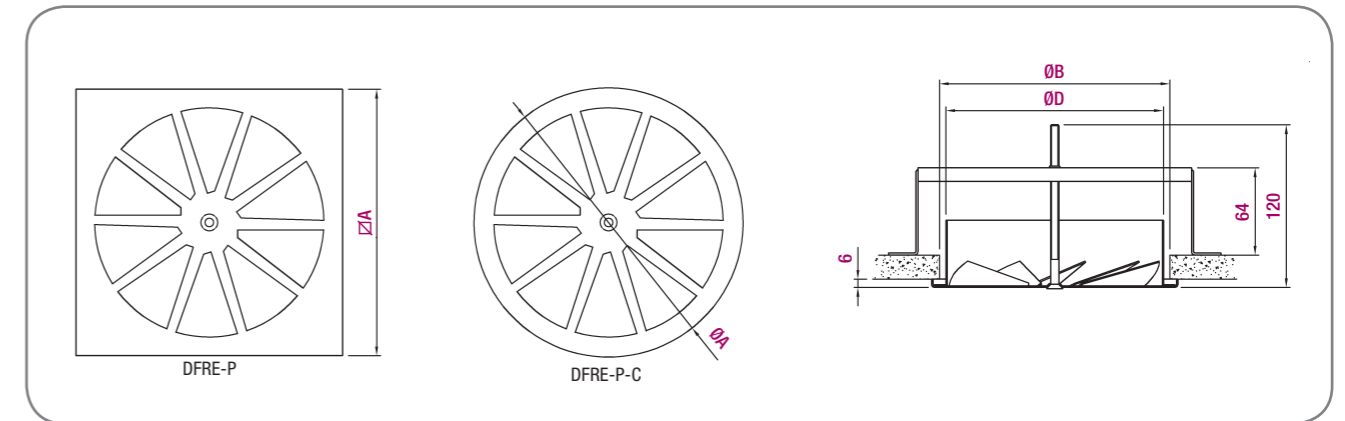

Nominal	A	B	D
100	Ø127 / Ø125	115	99
125	Ø152 / Ø150	135	124
160	Ø182 / Ø180	170	159

Unit mm

Selection table

Size	Q (m³/h)	L _{wa} [dB(A)]	ΔP _t (Pa)	V _x (m/s)
100	30	20	10	0.08
	37	26	15	0.10
	46	32	23	0.13
125	55	20	14	0.11
	68	26	21	0.15
160	85	32	32	0.18
	75	20	10	0.15
	95	26	16	0.19
	115	32	24	0.23

LEGEND

Q (m³/h): Air flow.
 ΔP_t (Pa): Total pressure loss.
 L_{wa} [dB(A)]: Sound power level.
 V_x (m/s): Maximum velocity of the air stream at 0.70 m from the diffuser.

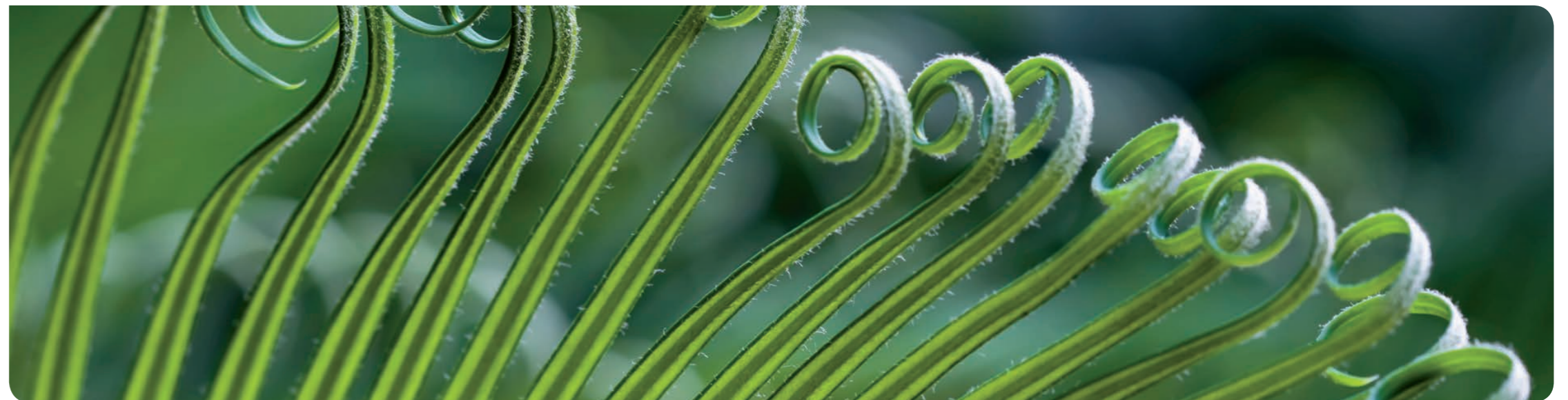

Fire dampers



Barceló Aranjuez Hotel (Madrid – Spain)

Linear diffusers S-70-18,
long-throw nozzle DF-49
and swirl diffusers DFRO.

SCFC



Catalogue Series SF



SCFC-PD

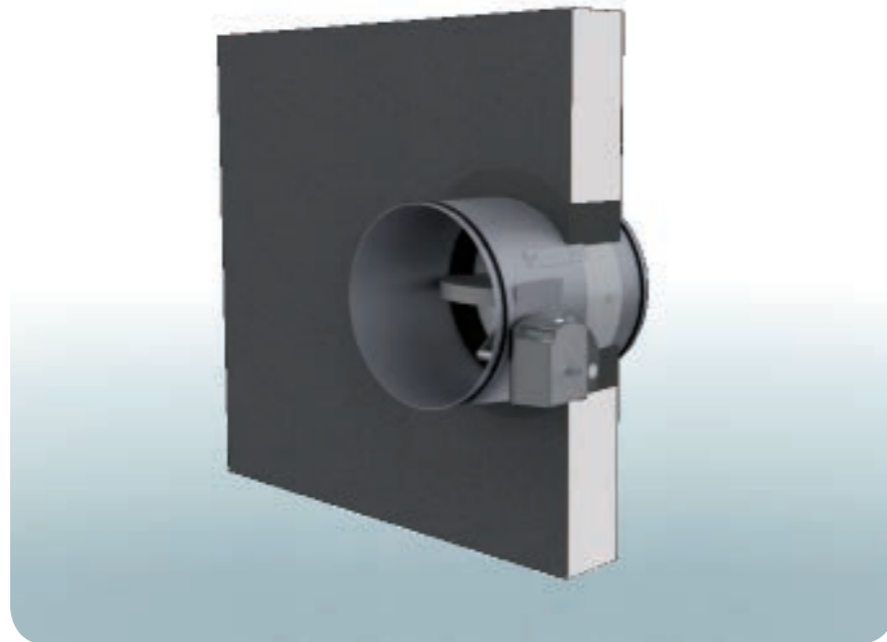

Circular fire damper

Product description

Circular fire dampers, KOOLAIR brand, models **SCFC**, are certified under the norm UNE EN 1366-2:2000. Dimensions \varnothing ...

The housing is composed of a single body of steel sheet with an innercutout reinforced by a slotted perforated frame that eliminates completely the thermal bridge.

The dampers are closed when the thermal fuse blows or trips at temperatures above 70°C and are manually reset in all versions.

The operating mechanism components are manufactured of zinc coated steel and built into a plastic casing.

The mechanism assembly is offset from the pivot shaft of the slat, which allows access to the unit for maintenance and inspection.

The Koolair fire dampers have the CE marking in accordance with the Construction Products Directive 305/2011/EU, following the standard EN15650:2010 and classification in accordance with EN 13501-3:2005. Also available with "NF" marking. Option for fire dampers to be supplied with class C air tightness in compliance with UNE-EN 1751.

Models

SCFC-PD S/UNE-EN 1366-2:2000. Circular fire damper class:

EI-120 (ve i ↔ o) S (500 Pa) for wall,
EI-180 (ho i ↔ o) S (500 Pa) for ceiling/floor slab,
EI-120 (ve i ↔ o) S (500 Pa) for flexible wall.
Dimensions from \varnothing 100 to \varnothing 355 mm

SCFC-GD S/UNE-EN 1366-2:2000. Circular fire damper class:

For sizes from \varnothing 400 to \varnothing 630 mm
EI-180 (ho i ↔ o) S (500 Pa) or ceiling/floor slab.
For sizes from \varnothing 200 to \varnothing 800 mm
EI-180 (ve i ↔ o) S (500 Pa) for wall.

Motor-driven circular fire dampers SCFC-PD and SCFC-GD can be incorporated into KOOLAIR's KOOLCOM system for managing and monitoring fire dampers.

Accessories

TH-70. Fusible link.

TH-70-FC. Fusible link + end of stroke switch.

TH-70-PC/FC. Fusible link + beginning and end of stroke switch.

B IMP 24V/48V DC-FC. Electromagnetic push coil (normally de-energized) 24V/48V DC, with end of stroke switch.

B IMP 24V/48V AC-C. Electromagnetic push coil normally de-energized) 24V/48V AC, with end of stroke switch.

B IMP 220V-FC. Electromagnetic push coil (normally de-energized) 220V AC, with end of stroke switch.

B RUP 24V/48V DC-FC. Electromagnetic pull coil (normally de-energized) 24V/48V DC, with end of stroke switch.

B RUP 24V/48V AC-FC. Electromagnetic pull coil (normally de-energized) 24V/48V AC, with end of stroke switch.

B RUP 220V-FC. Electromagnetic push coil (normally de-energized) 220V AC, with end of stroke switch.

MOTOR-24-T. Servomotor 24V AC/DC with thermo-fuse + beginning and end of stroke switch.

MOTOR-230-T. Servomotor 230V AC with thermo-fuse + beginning and end of stroke switch.

General dimensions (SCFC-PD)

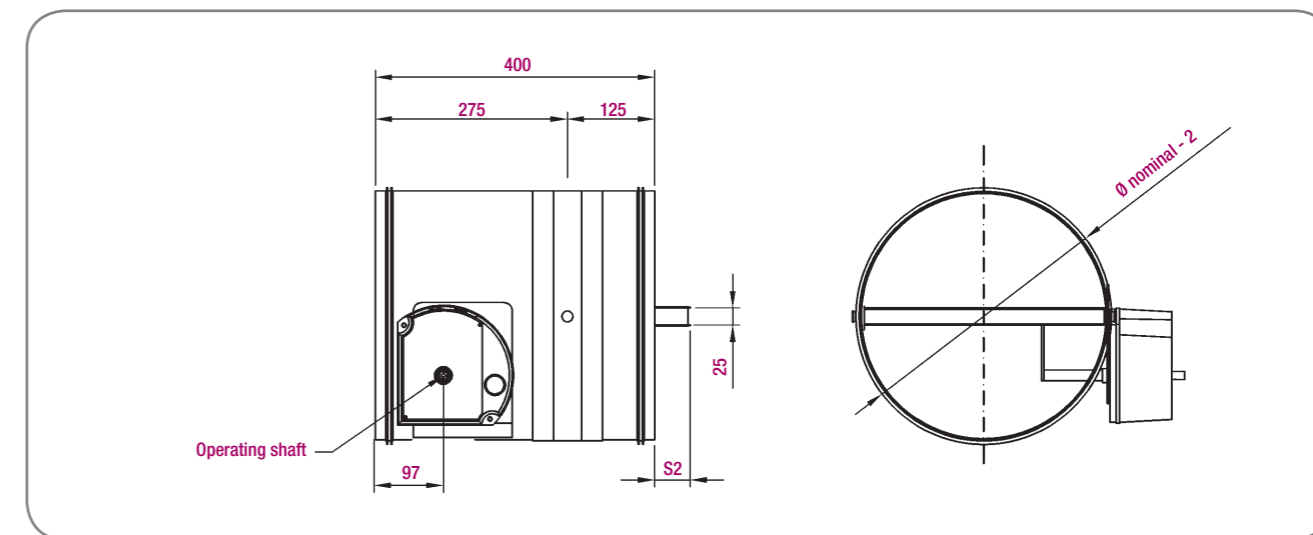

\varnothing Nominal	S2
100	—
125	—
160	—
200	—
250	—
315	25
355	50

Unit mm



SCFC

Selection table (SCFC-PD)

Size	Q (m³/h)	L _{WA} [dB(A)]	ΔP _t (Pa)	V _p (m/s)
100	75	25	18	4,2
	95	30	27	5,2
	115	35	41	6,4
125	165	30	19	5,3
	205	35	30	6,6
	250	40	45	8,1
160	380	35	22	6,8
	465	40	34	8,4
	575	45	51	10,4
200	800	40	22	8,7
	985	45	33	10,8
	1210	50	50	13,3
250	1350	40	22	9,0
	1660	45	34	11,1
	2050	50	52	13,7
315	2290	40	16	9,3
	2830	45	25	11,5
	3490	50	38	14,2
355	2770	40	13	8,7
	3410	45	20	10,8
	4210	50	30	13,3

LEGEND

Q (m³/h): Air flow.
 ΔP_t (Pa): Pressure drop.
 L_{WA} [dB(A)]: Sound power level.
 V_p (m/s): Effective velocity.

Selection table (SCFC-GD)

Size	Q (m³/h)	L _{WA} [dB(A)]	ΔP _t (Pa)	V _p (m/s)
400	3980	45	20	10,5
	4960	50	31	13,0
	6170	55	47	16,2
450	4650	45	13	9,5
	5790	50	21	11,8
	7210	55	32	14,7
500	5490	45	12	8,9
	6830	50	18	11,1
	8500	55	29	13,8
560	6590	45	11	8,4
	8200	50	16	10,4
	10210	55	25	13,0
630	7980	45	9	7,9
	9930	50	15	9,8
	12360	55	23	12,3
650	8590	45	10	8,0
	10690	50	15	9,9
	13300	55	23	12,3
700	9510	45	9	7,6
	11840	50	13	9,4
	14730	55	21	11,7
710	9680	45	8	7,5
	12040	50	13	9,3
	14990	55	20	11,6
750	10530	45	8	7,2
	13110	50	12	9,0
	16310	55	19	11,2
800	11720	45	8	7,0
	14580	50	13	8,8
	18140	55	20	10,9

LEGEND

Q (m³/h): Air flow.
 ΔP_t (Pa): Pressure drop.
 L_{WA} [dB(A)]: Sound power level.
 V_p (m/s): Effective velocity.



SCFR/SFR



Catalogue Series SF

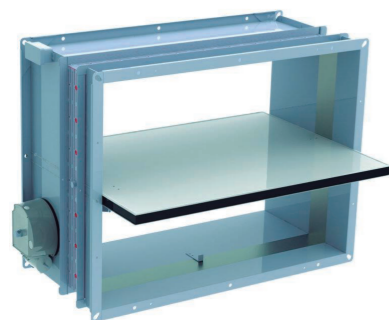

SCFR-PD

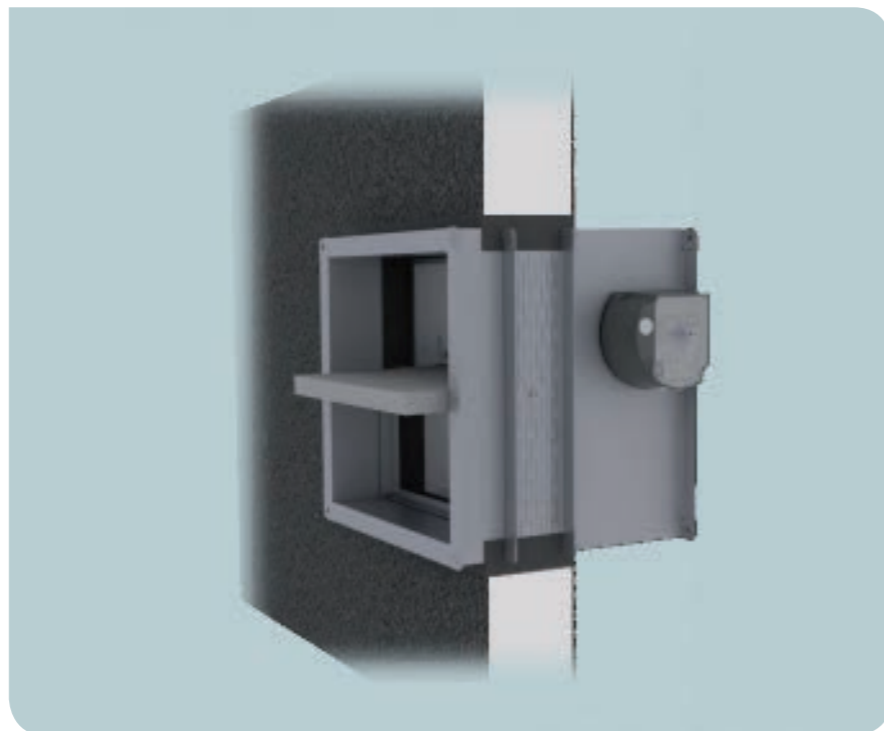

Rectangular fire damper

Product description

Rectangular fire dampers, KOOLAIR brand, model **SCFR**, are certified under the norm UNE EN 1366-2:2000. Dimensions LxH. The housing is composed of a single body of steel sheet with an innercutout reinforced by a slotted perforated frame that eliminates completely the thermal bridge.

The dampers are closed when the thermal fuse blows or trips at temperatures above 70°C and are manually reset in all versions.

The operating mechanism components are manufactured of zinc-coated steel and built into a plastic casing.

The mechanism assembly is offset from the pivot shaft of the slat, which allows access to the unit for maintenance and inspection.

The Koolair fire dampers have the CE marking in accordance with the Construction Products Directive 305/2011/EU, following the standard EN15650:2010 and classification in accordance with EN 13501-3:2005.

Also available with "NF" marking (SCFR-PD and SCFR-GD).

Option for fire dampers to be supplied with class C air tightness in compliance with UNE-EN 1751.

Models

SCFR-PD S/UNE-EN 1366-2:2000. Clasificación: EI-120 (ve i ↔ o) S (500 Pa) for wall, EI-180 (ho i ↔ o) S (500 Pa) for ceiling/floor slab, EI-120 (ve i ↔ o) S (500 Pa) for flexible wall. Damper dimension from 200x100 mm to 800x600 mm.

SCFR-GD S/UNE-EN 1366-2:2000. Clasificación: EI-120 (ve i ↔ o) S (500 Pa) for wall, EI-120 (ho i ↔ o) S (500 Pa) for ceiling/floor slab. Damper dimension from L>800 mm or H>600 mm to 1500x800 mm.

SFR3K1GT S/UNE-EN 1366-2:2000. Clasificación: EI-180 (ve i ↔ o) S (300 Pa) for wall. Damper dimension from 200x200 mm to 1500x800 mm.

Motor-driven rectangular fire dampers SCFR-PD, SCFR-GD and SFR3K1GT can be incorporated into KOOLAIR's KOOLCOM system for managing and monitoring fire dampers.

Accessories

TH-70. Fusible link.

TH-70-FC. Fusible link + end of stroke switch.

TH-70-PC/FC. Fusible link + beginning and end of stroke switch.

B IMP 24V/48V DC-FC. Electromagnetic push coil (normally de-energized) 24V/48V DC, with end of stroke switch.

B IMP 24V/48V AC-FC. Electromagnetic push coil normally de-energized) 24V/48V AC, with end of stroke switch.

B IMP 220V-FC. Electromagnetic push coil (normally de-energized) 220V AC, with end of stroke switch.

B RUP 24V/48V DC-FC. Electromagnetic pull coil (normally de-energized) 24V/48V DC, with end of stroke switch.

B RUP 24V/48V AC-FC. Electromagnetic pull coil (normally de-energized) 24V/48V AC, with end of stroke switch.

B RUP 220V-FC. Electromagnetic push coil (normally de-energized) 220V AC, with end of stroke switch.

MOTOR-24-T. Servomotor 24V AC/DC with thermo-fuse + beginning and end of stroke switch.

MOTOR-230-T. Servomotor 230V AC with thermo-fuse + beginning and end of stroke switch.

General dimensions (SCFR-PD)

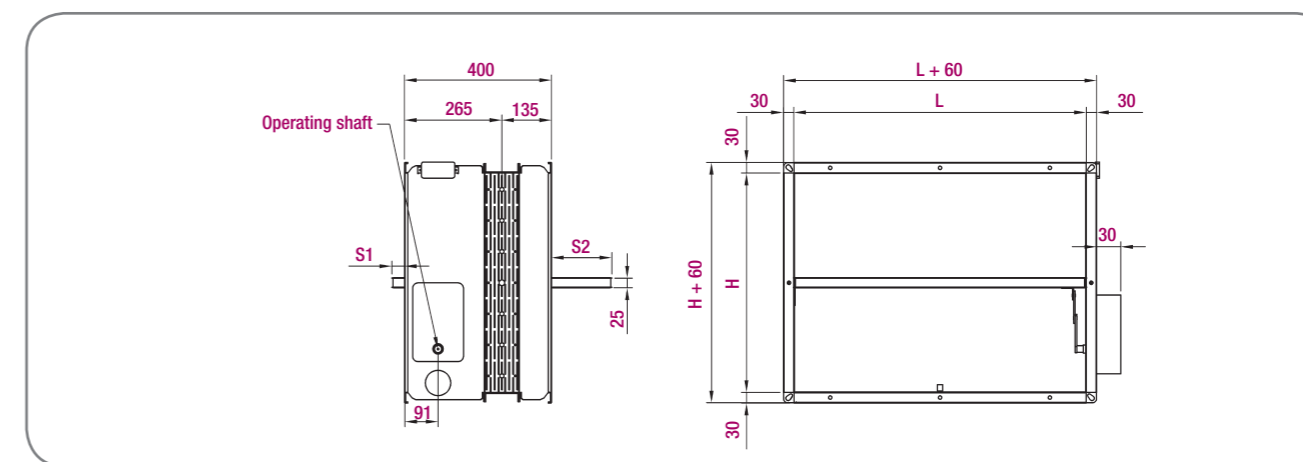

H	S1	S2
100	-	-
150	-	-
200	-	-
250	-	-
300	-	-
350	-	14
400	-	64
450	-	89
500	-	114
550	10	139
600	35	164

Unit mm



SCFR/SFR

Selection table (SCFR-PD)

Size	Q (m³/h)	L _{WA} [dB(A)]	ΔP _{st} (Pa)	V _p (m/s)
200x100	355	30	23	6,6
	435	35	34	8,0
	530	40	51	9,8
400x100	760	35	21	7,0
	925	40	31	8,6
	1130	45	46	10,5
250x200	1130	35	17	7,2
	1380	40	25	8,7
	1680	45	38	10,7
400x200	2160	40	15	8,6
	2630	45	22	10,4
	3200	50	33	12,7
350x250	2460	40	13	8,7
	3000	45	20	10,6
	3660	50	29	12,9
400x300	3420	40	10	8,6
	4180	45	16	10,6
	5100	50	23	12,9
800x200	4130	40	9	8,2
	5040	45	14	10,0
	6150	50	21	12,2
500x400	4570	40	6	6,8
	5600	45	10	8,3
	6860	50	14	10,2
700x350	6150	40	8	7,5
	7540	45	12	9,2
	9240	50	18	11,3
650x450	5260	40	4	5,3
	6440	45	6	6,5
	7900	50	9	7,9
750x550	7950	40	4	5,6
	9740	45	7	6,9
	11940	50	10	8,4
800x600	8830	40	4	5,3
	10820	45	6	6,5
	13260	50	9	8,0



LEGEND

Q (m³/h): Air flow.
 ΔP_t (Pa): Pressure drop.
 L_{WA} [dB(A)]: Sound power level.
 V_p (m/s): Effective velocity.

Selection table (SCFR-GD)

Size	Q (m³/h)	L _{WA} [dB(A)]	ΔP _{st} (Pa)	V _p (m/s)
900x200	2400	40	19	4,9
	2930	45	29	6,0
	3570	50	43	7,4
850x300	4390	45	20	5,7
	5380	50	31	7,0
	6590	55	46	8,6
1400x350	8630	45	12	5,7
	10570	50	18	7,0
	12960	55	27	8,6
850x650	11080	45	10	6,0
	13580	50	16	7,4
	16640	55	24	9,1
900x700	12980	45	9	6,2
	15900	50	13	7,6
	19500	55	20	9,3
1250x600	19420	50	11	7,8
	23800	55	16	9,6
	19420	50	11	7,8
1000x750	16890	45	7	6,7
	20700	50	11	8,2
	25370	55	17	10,1
950x800	17290	45	7	6,7
	21190	50	11	8,3
	25970	55	16	10,1
1300x600	17370	45	7	6,7
	21290	50	11	8,3
	26090	55	16	10,1
1150x700	18420	45	7	6,8
	22580	50	10	8,4
	27670	55	15	10,3
1100x800	21090	45	6	7,1
	25850	50	9	8,7
	31680	55	14	10,7
1500x800	28900	45	6	7,1
	35420	50	9	8,7
	43400	55	14	10,7



LEGEND

Q (m³/h): Air flow.
 ΔP_t (Pa): Pressure drop.
 L_{WA} [dB(A)]: Sound power level.
 V_p (m/s): Effective velocity.

BDK



Catalogue Series BDK

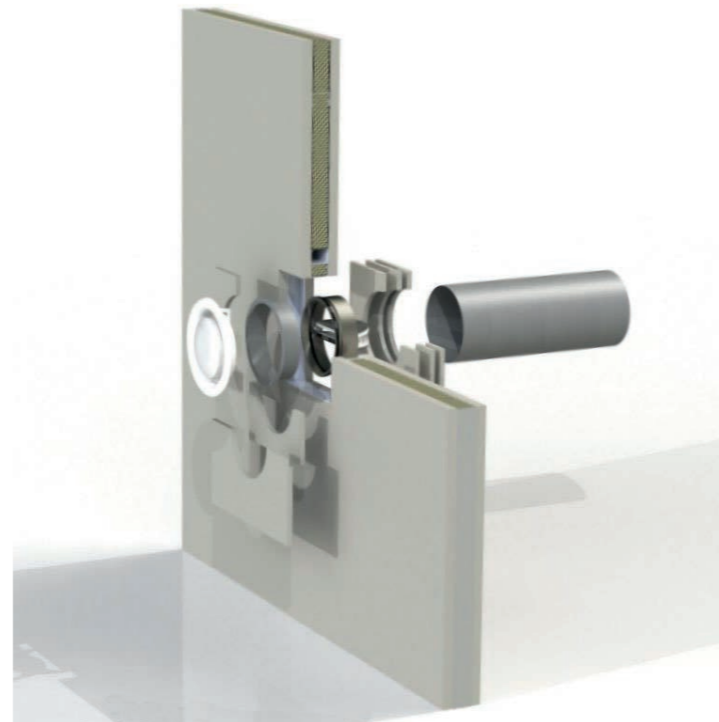
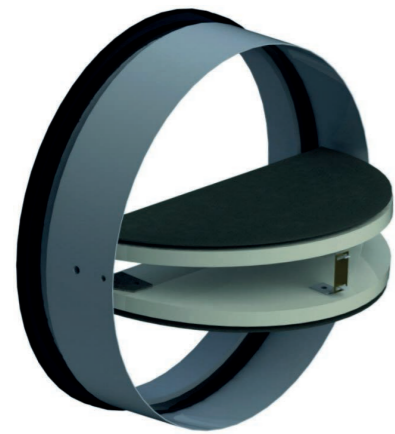

Butterfly fire damper

Product description

The Koolair **BDK** butterfly fire dampers are certified according to the Technical Building Code as per UNE EN 1366-2.

They are used inside circular HVAC ducts in wall pass-throughs to fire propagation.

Operation

The BDK damper remains open because of the fuse link. When the temperature exceeds 72°C, the fuse link melts and the mechanism is released, such that the fins close automatically.

Two bands ensure that the damper remains closed. After closure, the damper fins are mechanically secured in the closed position and can only be opened manually.

Models

BDK-60: Butterfly firewall dampers with fire integrity and insulation rated at 60 min plus smoke tightness. EI 60 (ve i → o) S.

BDK-120: Butterfly firewall dampers with fire integrity and insulation rated at 120 min plus smoke tightness. EI 120 (ve i → o) S.

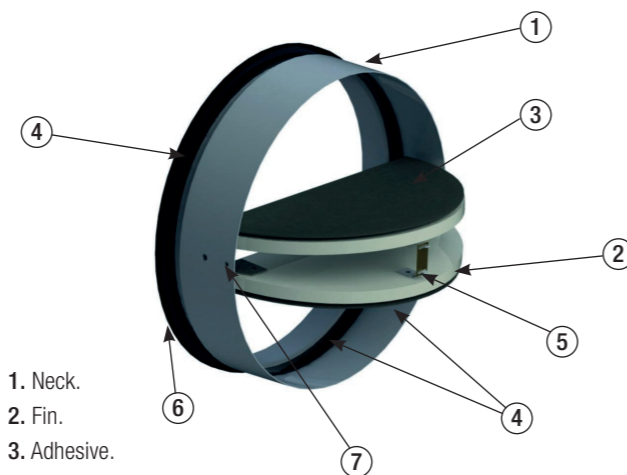

1. Neck.
2. Fin.
3. Adhesive.
4. Intumescent gasket.
5. Fuse link, 72°C.
6. Rubber gasket.
7. Band.

Accessories

FC. End stroke switch.

GPD-Ø. Extract valves and mounting frame.

AM. Mounting ring.

General dimensions

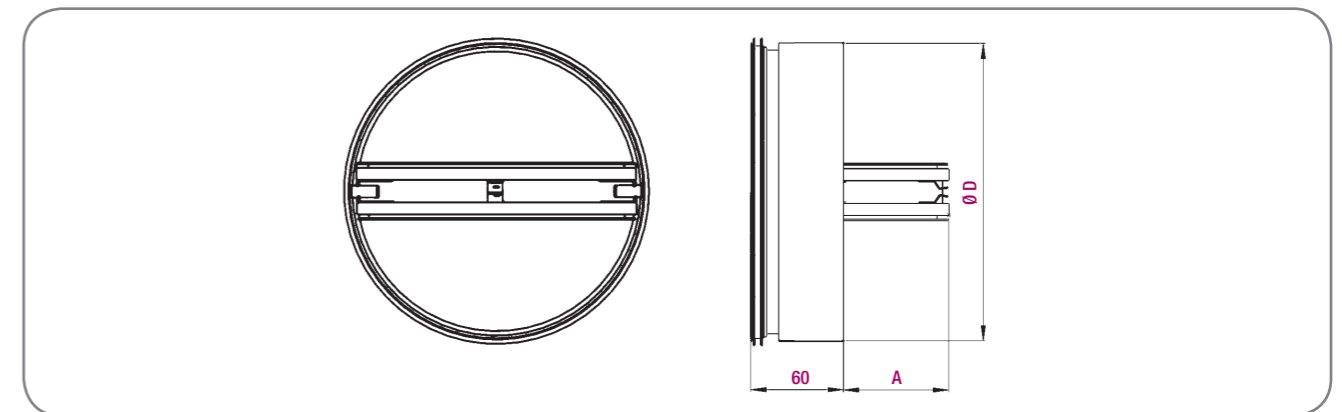

Nominal	D	A	Ø HOLE1	HOLE2
100	98,5	20	150	200x200
125	123,5	33	175	225x225
150	148,5	41	200	250x250
160	158,5	51	210	260x260
180	178,5	61	230	280x280
200	198,5	71	250	300x300

Unit mm

Ø Hole1: Rigid wall
Hole2: Flexible wall

Selection table

Size	Q (m³/h)	L _{wa} [dB(A)]	ΔP _{st} (Pa)	V _p (m/s)
100	88	30	17	3,1
	109	35	27	3,9
	136	40	41	4,8
	168	45	61	6,0
125	150	30	17	3,4
	186	35	26	4,2
	231	40	40	5,2
	287	45	61	6,5
150	231	30	16	3,6
	287	35	25	4,5
	357	40	38	5,6
	444	45	59	7,0
160	270	30	16	3,7
	335	35	24	4,6
	417	40	38	5,8
	518	45	58	7,2
180	357	30	15	3,9
	444	35	24	4,8
	552	40	37	6,0
	686	45	57	7,5
200	460	30	15	4,1
	571	35	23	5,1
	710	40	36	6,3
	882	45	56	7,8



LEGEND

Q (m³/h): Air flow.
ΔP_t (Pa): Pressure drop.
L_{wa} [dB(A)]: Sound power level.
V_p (m/s): Effective velocity.

CEVH



Catalogue Series CEVH

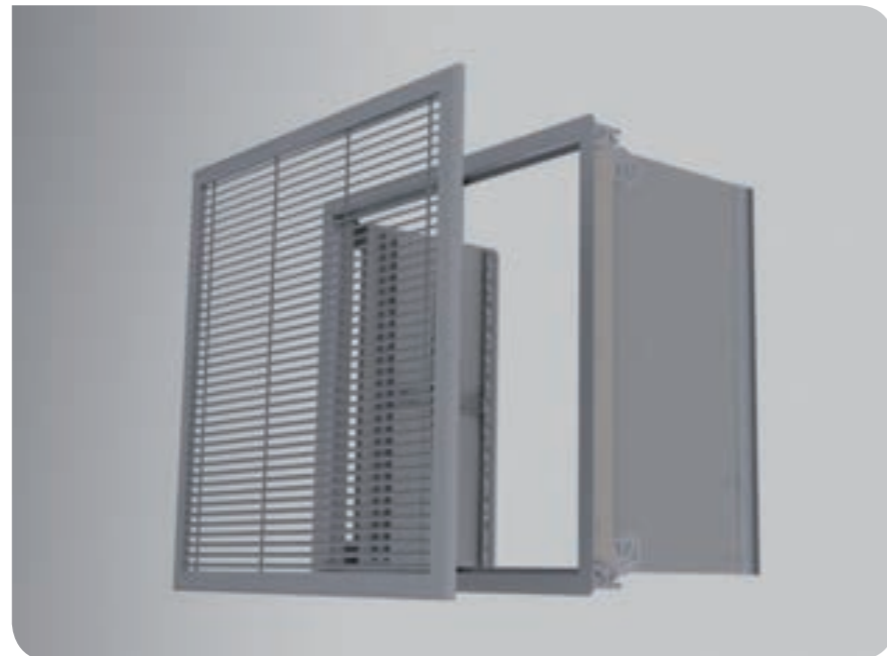

Smoke evacuation damper

Product description

Smoke evacuation damper, hinged, to be used for new air and smoke evacuation in public buildings and tall buildings; EN 1366-10 approved. Designed as per EN 12101-8 specifications.

Composed of a structure of refractory material externally and steel plate internally, and composed of two hinged sections in refractory material.

Application: by a wall- or duct-recessed mounting frame. Front panel with specific protection grille for smoke evacuation, in anodized aluminium.

UNE-EN-1366-10 certificate. EN 13501-4 classification: EI 120 (ved i<->o) S 1500 AA multi.

The CEVH smoke evacuation dampers have CE Mark No. 0370-CPR-1687, in conformity with Construction Products Directive 89/106/EC, as per EN12101-8.

Dimensions

The CEVH 2P damper can have the following dimensions:

Minimum dimension LxH (mm) - 400x400

Maximum dimension LxH (mm) - 1100x1100.

Operation

The mechanism(s) will be installed in a specific area, in the middle of the damper.

Smoke evacuation damper, hinged, electromagnetic operation at 24/48V by current emission.

Option to include position contacts to indicate the open and/or closed positions (optional).

Installation

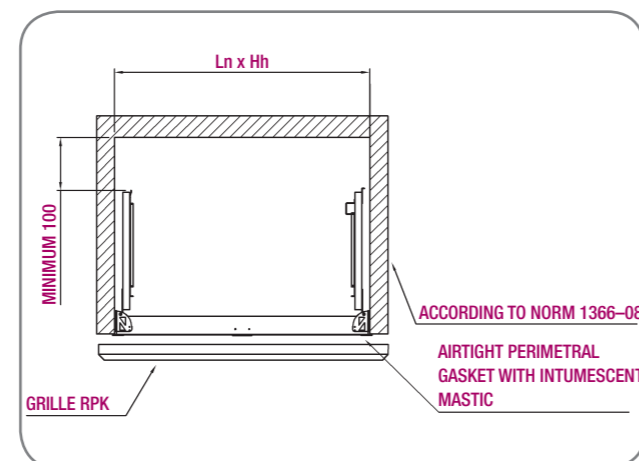

General dimensions

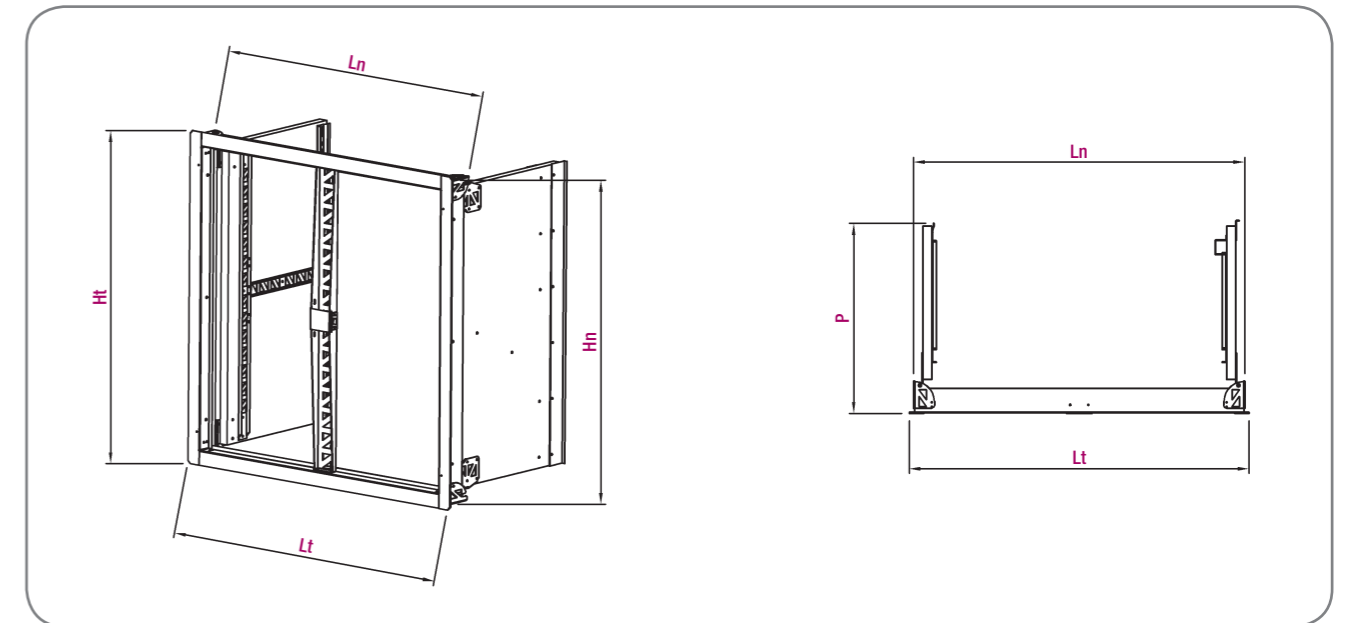

Free area (dm²)

Height Hn (in mm)	Length Ln (in mm)														
	400	450	500	550	600	650	700	750	800	850	900	950	1000	1050	1100
400	9.24	10.76	12.28	13.80	15.3	16.8	18.4	19.9	21.4	22.9	24.4	26.0	27.5	29.0	30.5
450	10.76	12.53	14.30	16.07	17.8	19.6	21.4	23.2	24.9	26.7	28.5	30.2	32.0	33.8	35.5
500	12.28	14.30	16.32	18.34	20.4	22.4	24.4	26.4	28.4	30.5	32.5	34.5	36.5	38.5	40.6
550	13.80	16.07	18.34	20.61	22.9	25.2	27.4	29.7	32.0	34.2	36.5	38.8	41.0	43.3	45.6
600	15.32	17.84	20.36	22.88	25.4	27.9	30.4	33.0	35.5	38.0	40.5	43.0	45.6	48.1	50.6
650	16.84	19.61	22.38	25.15	27.9	30.7	33.5	36.2	39.0	41.8	44.5	47.3	50.1	52.9	55.6
700	18.36	21.38	24.40	27.42	30.4	33.5	36.5	39.5	42.5	45.5	48.6	51.6	54.6	57.6	60.6
750	19.88	23.15	26.42	29.69	33.0	36.2	39.5	42.8	46.0	49.3	52.6	55.9	59.1	62.4	65.7
800	21.40	24.92	28.44	31.96	35.5	39.0	42.5	46.0	49.6	53.1	56.6	60.1	63.6	67.2	70.7
850	22.92	26.69	30.46	34.23	38.0	41.8	45.5	49.3	53.1	56.9	60.6	64.4	68.2	71.9	75.7
900	24.44	28.46	32.48	36.50	40.5	44.5	48.6	52.6	56.6	60.6	64.6	68.7	72.7	76.7	80.7
950	25.96	30.23	34.50	38.77	43.0	47.3	51.6	55.9	60.1	64.4	68.7	72.9	77.2	81.5	85.7
1000	27.48	32.00	36.52	41.04	45.6	50.1	54.6	59.1	63.6	68.2	72.7	77.2	81.7	86.2	90.8
1050	29.00	33.77	38.54	43.31	48.1	52.9	57.6	62.4	67.2	71.9	76.7	81.5	86.2	91.0	95.8
1100	30.52	35.54	40.56	45.58	50.6	55.6	60.6	65.7	70.7	75.7	80.7	85.7	90.8	95.8	101

FREE AREA FORMULA ((Ln-96) x (Hn-96))/10000

Pressure loss ≤ 20 Pa if velocity at damper is ≤ 8 m/s

LEGEND

- P = Blade depth.
- Lt = Overall length.
- Ht = Overall height.
- Lh = Duct internal length.
- Hh = Duct internal height.
- Ln = Damper Nominal length.
- Hn = Damper nominal height.

FORMULARY

- P = (Ln/2)+90
- Lt = Ln + 29
- Ht = Hn + 29
- Lh = Ln + 10
- Hh = Hn + 10

CEVH-1P



Catalogue Series CEVH-1P



Smoke evacuation damper

Product description

Smoke evacuation damper with 1-blade (1P) swivelling closure, designed to be used for the supply of primary air and smoke evacuation in public buildings and high-rise buildings. Approved in accordance with EN 1366-10. Designed according to EN 12101-8 specifications.

Composed of a structure with a refractory material externally, sheet steel internally and a hinged door made of a refractory material. For installation in vertical smoke evacuation ducts, with the option of a metal mounting frame previously fixed to the duct. The face that is on display within the room has the option of a decorative plate made of a refractory material (CEVH-1P + DECO) and/or a protective and decorative grille specific for smoke evacuation, model RPK, made of anodised aluminium profiles. Certified in accordance with standard UNE-EN-1366-10. Classified in accordance with EN 13501-4: EI 120 (ved i↔o) S 1500 AA multi.

CEVH-1P smoke evacuation dampers carry CE marking No. 0370-CPR-3051 in accordance with the European Construction Products Regulation RPC-305, according to EN12101-8.

Dimensions

The CEVH 1P damper is available with the following dimensions:

Minimum dimension LxH (mm) - 300x385
Maximum dimension LxH (mm) - 700x1100.

Operation

Activation (opening) by means of electric shunt release coil with manual/motorised reset (closing). Optional end of run limit switch/es. Types of coil (electromagnet) available:

- Electric shunt release 24 V – DC.
- Electric shunt release 48 V – DC.
- Electric shunt release 24 V – AC.
- Electric shunt release 48 V – AC.
- Electric shunt release 220 V – AC.

The activation and reset mechanism is incorporated in the lower front part of the damper protected from passing smoke and high temperatures.

Installation

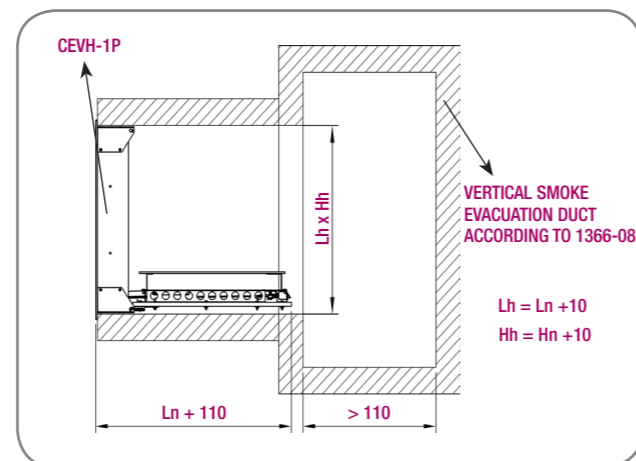

For more information refer to catalogue.

General dimensions

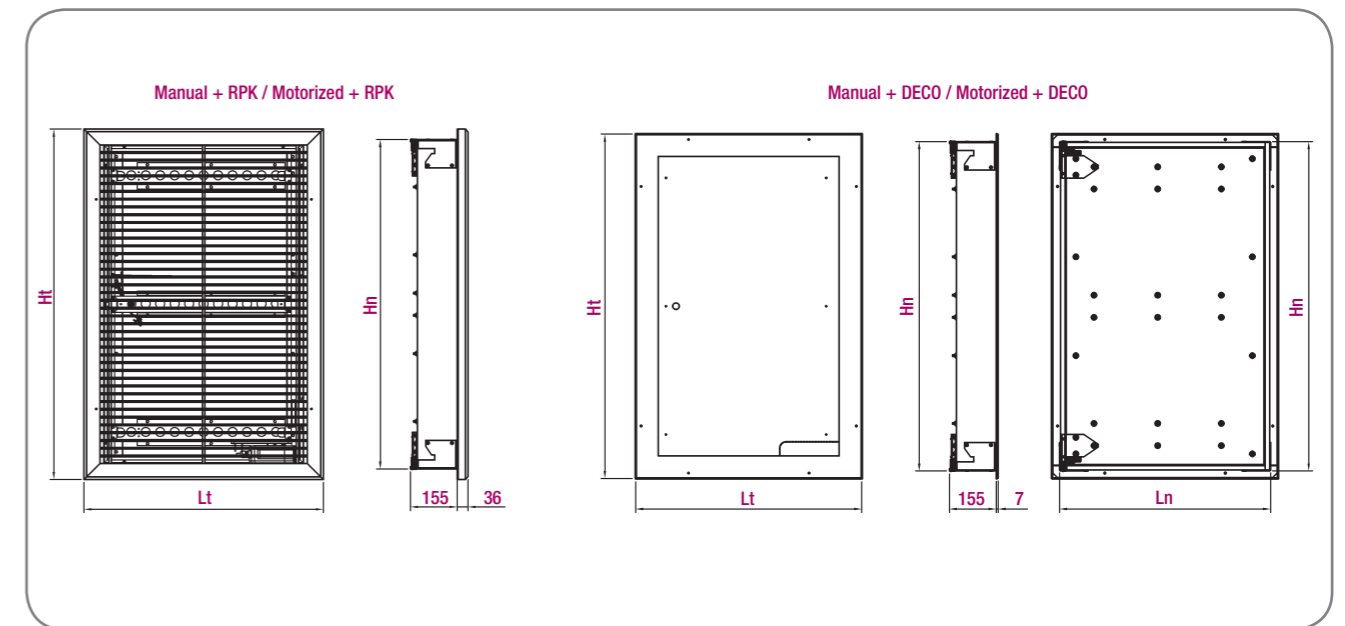

Free area (m²)

Height Hn (in mm)	Length Ln (in mm)								
	300	350	400	450	500	550	600	650	700
385	0,12	0,13	0,15	0,17	0,19	0,21	0,23	0,25	0,27
400	0,12	0,14	0,16	0,18	0,20	0,22	0,24	0,26	0,28
450	0,14	0,16	0,18	0,2025	0,225	0,2475	0,27	0,2925	0,315
500	0,15	0,18	0,20	0,225	0,25	0,275	0,30	0,325	0,35
550	0,17	0,19	0,22	0,2475	0,275	0,3025	0,33	0,3575	0,385
600	0,18	0,21	0,24	0,27	0,30	0,33	0,36	0,39	0,42
650	0,20	0,23	0,26	0,2925	0,325	0,3575	0,39	0,4225	0,455
700	0,21	0,25	0,28	0,315	0,35	0,385	0,42	0,455	0,49
750	0,23	0,26	0,30	0,3375	0,375	0,4125	0,45	0,4875	0,525
800	0,24	0,28	0,32	0,36	0,40	0,44	0,48	0,52	0,56
850	0,26	0,30	0,34	0,3825	0,425	0,4675	0,51	0,5525	0,595
900	0,27	0,32	0,36	0,405	0,45	0,495	0,54	0,585	0,63
950	0,29	0,33	0,38	0,4275	0,475	0,5225	0,57	0,6175	0,665
1000	0,30	0,35	0,40	0,45	0,50	0,55	0,60	0,65	0,70
1050	0,32	0,37	0,42	0,4725	0,525	0,5775	0,63	0,6825	0,735
1100	0,33	0,39	0,44	0,495	0,55	0,605	0,66	0,715	0,77

Pressure loss ≤ 20 Pa if velocity at damper is ≤ 8 m/s

LEGEND

- P = Blade depth.
- Lt = Overall length.
- Ht = Overall height.
- Lh = Duct internal length.
- Hh = Duct internal height.
- Ln = Damper Nominal length.
- Hn = Damper nominal height.

FORMULARY

- P = Ln + 110
- CEVH-1P+DECO** Lt = Ln + 50
- CEVH-1P+RPK** Lt = Ln + 94
- Ht = Hn + 50
- Ht = Hn + 70

SMLD



Catalogue Series SMLD

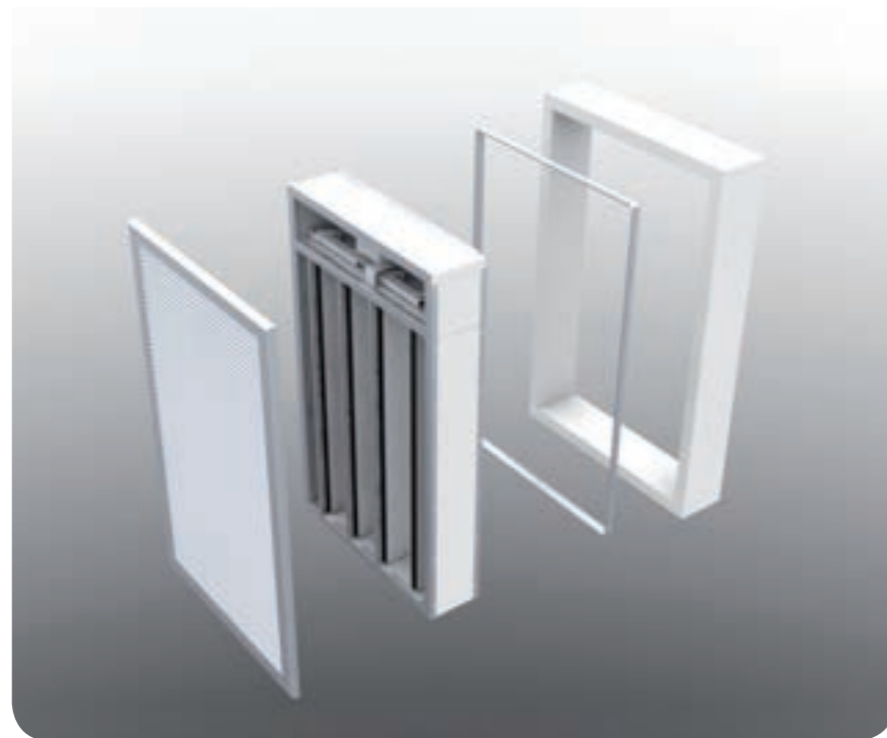

Smoke evacuation damper

Product description

Multiblade **smoke evacuation damper**, appropriate for applications in shallow ducts, EN 1366-10 approved.

Designed as per EN 12101-8 specifications. Composed of a refractory structure, externally enclosed with steel plate; composed of various refractory blades in the passage area.

Application: by a wall- or duct-recessed mounting frame.

Front panel with specific protection grille for smoke evacuation, in anodized aluminium.

UNE-EN-1366-10 certificate.

EN 13501-4 classification:

EI 120 (ved i<->o) S 1500 AA multi.

The SMLD smoke evacuation dampers have CE Mark No. 0370-CPR-1688, in conformity with Construction Products Directive 89/106/EC, as per EN12101-8.

Dimensions

Length: 360, 530 and 700 mm
Height: 200 mm to 1000 mm, in 50-mm increments.

Operation

The mechanism(s) will be installed in a specific area at the top of the damper and protected from smoke and temperature.

Multiblade smoke evacuation damper, electromagnetic operation at 24/48V by make circuit. Option to include position contacts to indicate the open and/or closed positions (optional). Motor drive option.

Motor-driven smoke evacuation dampers SMLD can be incorporated into KOOLAIR's KOOLCOM system for managing and monitoring fire dampers.

General dimensions

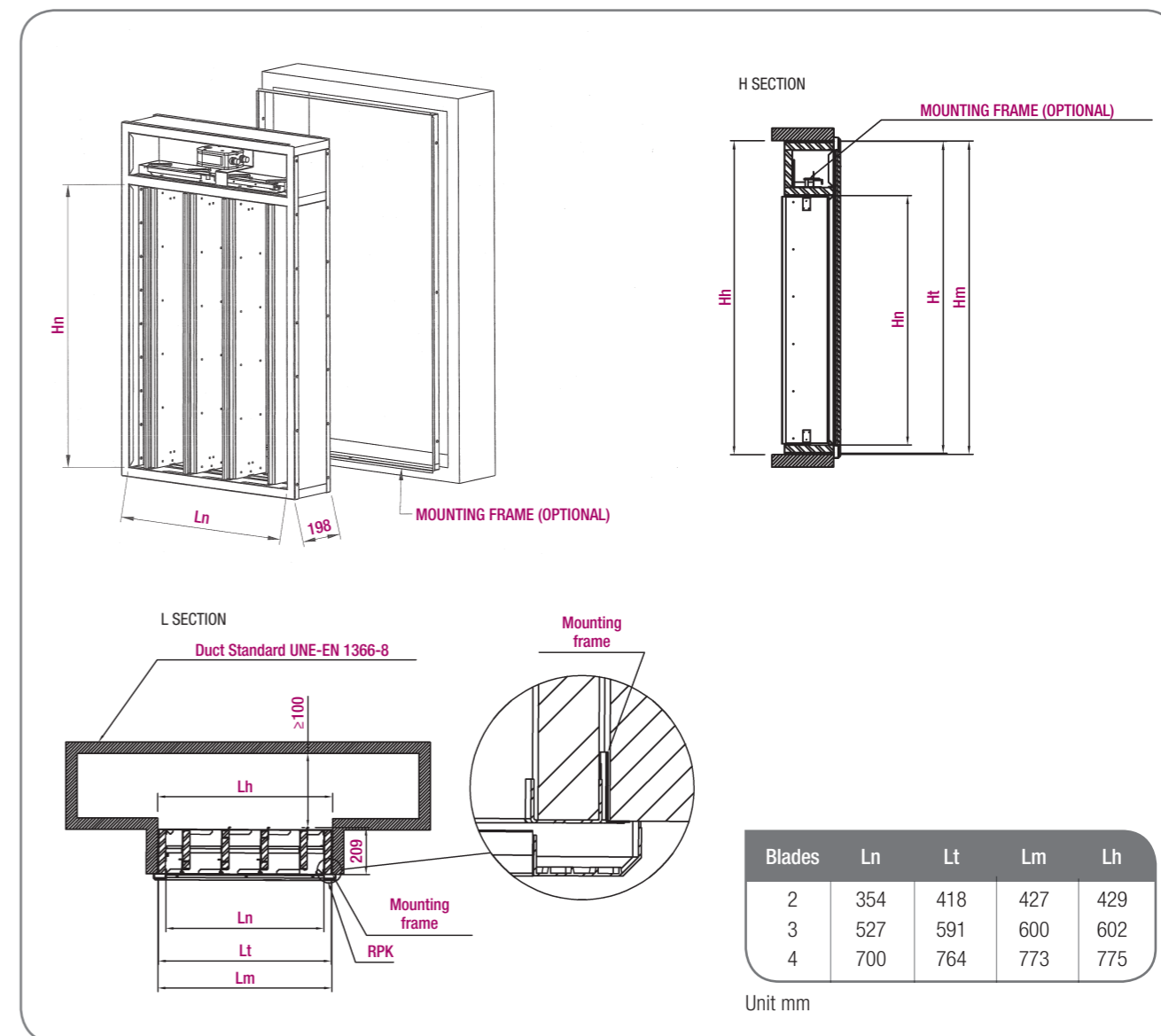

Free area (dm²)

Blades	Ln (mm)	Height Hn (mm)																
		200	250	300	350	400	450	500	550	600	650	700	750	800	850	900	950	1000
2	354	4.9	6.1	7.3	8.5	9.8	11.0	12.2	13.4	14.6	15.9	17.1	18.3	19.5	20.7	22.0	23.2	24.4
3	527	7.3	9.2	11.0	12.8	14.6	16.5	18.3	20.1	22.0	23.8	25.6	27.5	29.3	31.1	32.9	34.8	36.6
4	700	9.8	12.2	14.6	17.1	19.5	22.0	24.4	26.8	29.3	31.7	34.2	36.6	39.0	41.5	43.9	46.4	48.8

Pressure loss ≤ 40 Pa if velocity at damper is ≤ 8 m/s

LEGEND

L = Length
H = Height
Ln = Nominal length
Hn = Nominal height
Lt = Total length

Ht = Total height
Lm = Mounting frame length
Hm = Mounting frame height
Lh = Opening length
Hh = Opening height

FORMULARY

H = Hn
Ht = Hn + 249
Hm = Hn + 255
Hh = Hn + 257



RPK protection grille for use in smoke evacuation

Product description

Protection grille, in anodized aluminium, to be used for smoke evacuation or **SMLD** and **CEVH** damper protection.

Excellent aesthetics. Reduced pressure drop. Standard natural anodized aluminium finish.

Models

RPK. Protection grille with fixed core and visible screws.

RPK-1A. Protection grille with removable core and visible screws.

RPK-2A. Protection grille with removable core and hidden screws.

RPK-S. Protection grille with fixed core and visible screws.

RPK-P. Protection grille with fixed core and hidden screws.

RPK-X. Protection grille with folding core and hidden screws.

Option of safety screws (-SG).

Dimensions

The grilles adapt to the dimensions of the smoke evacuation damper.



General dimensions

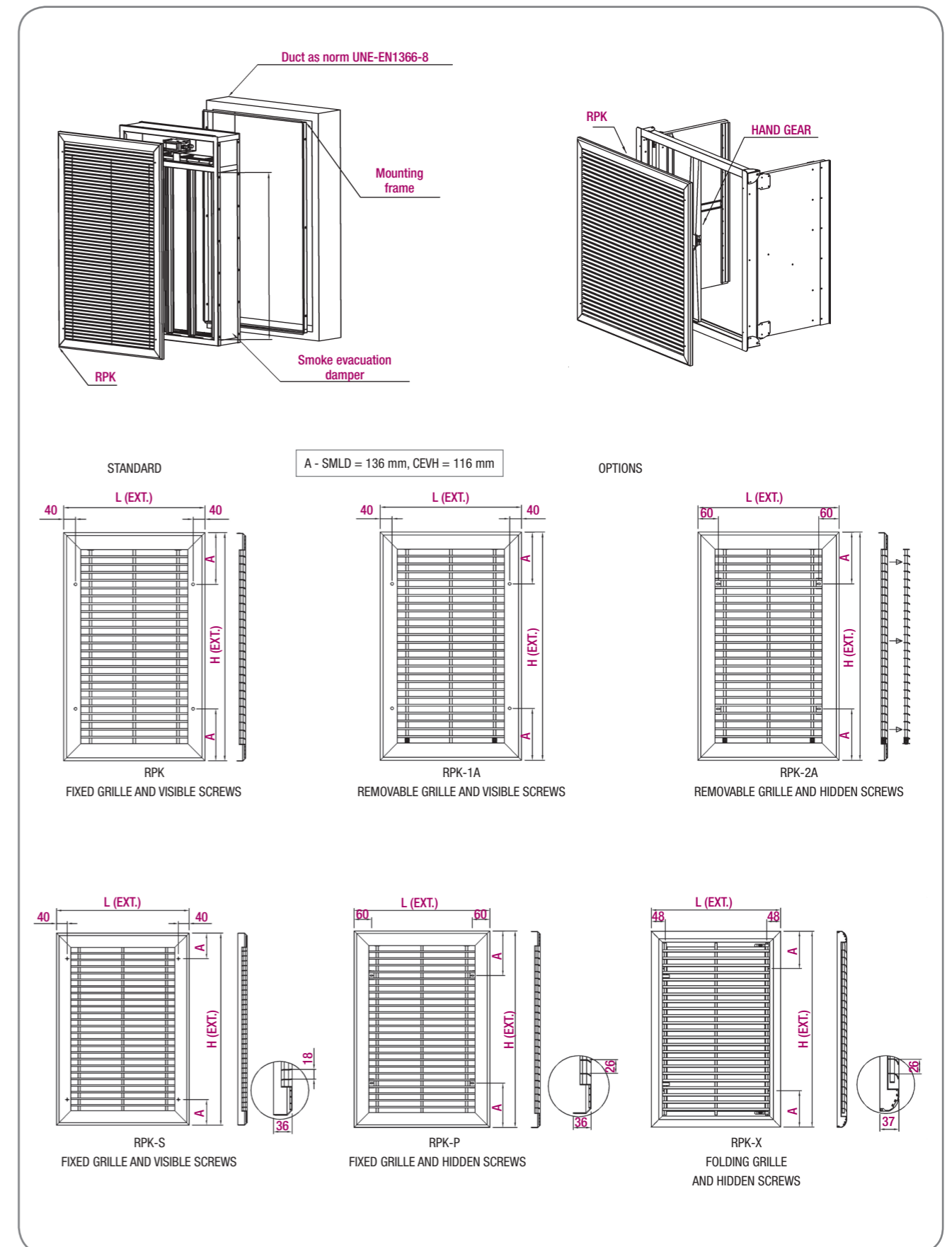

SCDC



Catalogue Series SCDC



Smoke evacuation damper

Product description

KOOLAIR's rectangular smoke evacuation damper, model **SCDC**, is composed of a single body of heat-resistant material, with steel flanges on either side (optional) to facilitate mounting in rectangular ducts, and a single heat resistant closing blade.

Tunnel type damper for in-line installation in horizontal ducts for use with both supply and extract, certified according to EN 1366-10, classified according to EN 13501-4; EI 120 (ved i ↔ o) S 1500 AA multi.

The SCDC smoke damper has the 0370 - CPR - 2600 certificate of constancy of performance according to EU Regulation (CE marking).

Designed according to EN 12101-8 specifications.

Activation

- Automatic actuation and reset by servomotor: SCDC smoke extract dampers are activated and reset by means of a servomotor with a supply voltage of 24 V AC/DC (model BLE24) or 230 V AC (model BLE230). These motors include start and end of stroke limit switches to monitor the opening/closing status of the damper.

Other activation options:

- Manual reset, activation by electric coil. Optional end of run limit switch:

24V electric drive coil DC

48V electric drive coil DC

24V electric drive coil AC

48V electric drive coil AC

- Automatic reset by means of servomotor

BL24-48, with a supply voltage of

24 ... 48 V AC/DC, activation by previously

mentioned electric coils. An end of run limit switch can be optionally incorporated.

The SCDC smoke damper, can be associated with KOOLCOM's KOOLAIR management and monitoring system for fire dampers.

General dimensions

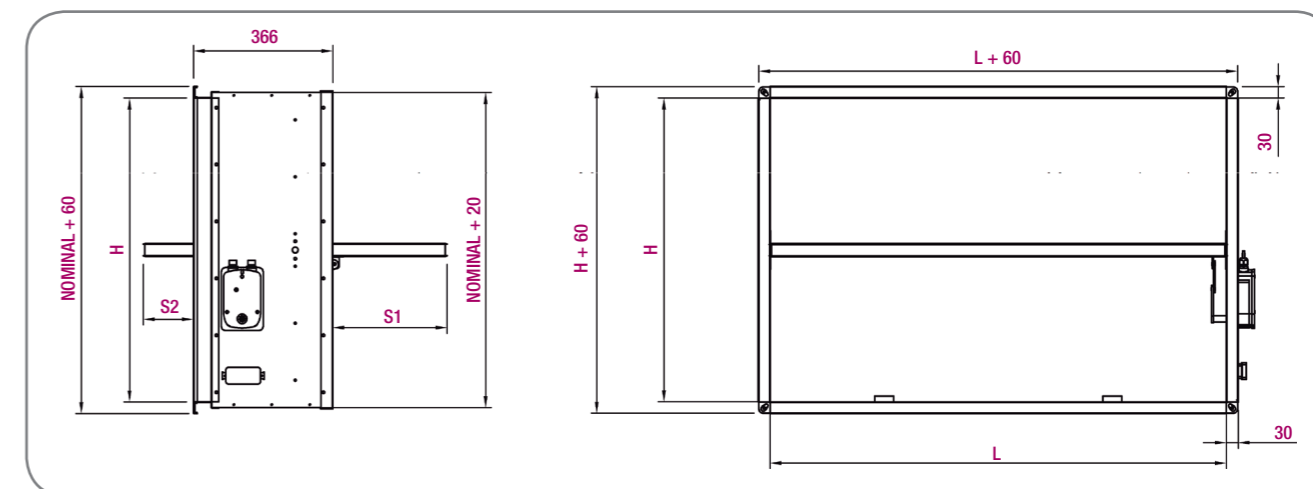

NOMINAL	H	S1	S2
200	200	0	0
250	250	25	0
300	300	50	0
350	350	75	0
400	400	100	0
450	450	125	0
500	500	150	0
550	550	175	7
600	600	200	32
650	650	225	57
700	700	250	82
750	750	275	107
800	800	300	132

Unit mm



Free area (dm²)

Height H (in mm)	Length L (in mm)																				
	200	250	300	350	400	450	500	550	600	650	700	750	800	850	900	950	1000	1050	1100	1150	1200
200	2,9	3,7	4,5	5,3	6,0	6,8	7,6	8,4	9,1	9,9	10,7	11,5	12,2	13,0	13,8	14,6	15,3	16,1	16,9	17,7	18,4
250	3,9	4,9	5,9	7,0	8,0	9,0	10,0	11,1	12,1	13,1	14,1	15,2	16,2	17,2	18,2	19,3	20,3	21,3	22,3	23,4	24,4
300	4,8	6,1	7,4	8,7	9,9	11,2	12,5	13,8	15,0	16,3	17,6	18,9	20,1	21,4	22,7	24,0	25,2	26,5	27,8	29,1	30,3
350	5,8	7,3	8,8	10,4	11,9	13,4	14,9	16,5	18,0	19,5	21,0	22,6	24,1	25,6	27,1	28,7	30,2	31,7	33,2	34,8	36,3
400	6,7	8,5	10,3	12,1	13,8	15,6	17,4	19,2	20,9	22,7	24,5	26,3	28,0	29,8	31,6	33,4	35,1	36,9	38,7	40,5	42,2
450	7,7	9,7	11,7	13,8	15,8	17,8	19,8	21,9	23,9	25,9	27,9	30,0	32,0	34,0	36,0	38,1	40,1	42,1	44,1	46,2	48,2
500	8,6	10,9	13,2	15,5	17,7	20,0	22,3	24,6	26,8	29,1	31,4	33,7	35,9	38,2	40,5	42,8	45,0	47,3	49,6	51,9	54,1
550	9,6	12,1	14,6	17,2	19,7	22,2	24,7	27,3	29,8	32,3	34,8	37,4	39,9	42,4	44,9	47,5	50,0	52,5	55,0	57,6	60,1
600	10,5	13,3	16,1	18,9	21,6	24,4	27,2	30,0	32,7	35,5	38,3	41,1	43,8	46,6	49,4	52,2	54,9	57,7	60,5	63,3	66,0
650	11,5	14,5	17,5	20,6	23,6	26,6	29,6	32,7	35,7	38,7	41,7	44,8	47,8	50,8	53,8	56,9	59,9	62,9	65,9	69,0	72,0
700	12,4	15,7	19,0	22,3	25,5	28,8	32,1	35,4	38,6	41,9	45,2	48,5	51,7	55,0	58,3	61,6	64,8	68,1	71,4	74,7	77,9
750	13,4	16,9	20,4	24,0	27,5	31,0	34,5	38,1	41,6	45,1	48,6	52,2	55,7	59,2	62,7	66,3	69,8	73,3	76,8	80,4	83,9
800	14,3	18,1	21,9	25,7	29,4	33,2	37,0	40,8	44,5	48,3	52,1	55,9	59,6	63,4	67,2	71,0	74,7	78,5	82,3	86,1	89,8

LEGEND

L = Interior length of damper.

H = Interior height of damper.

Pressure loss <35 Pa if velocity at damper is ≤ 8 m/s



Intumescent grilles for air transfer

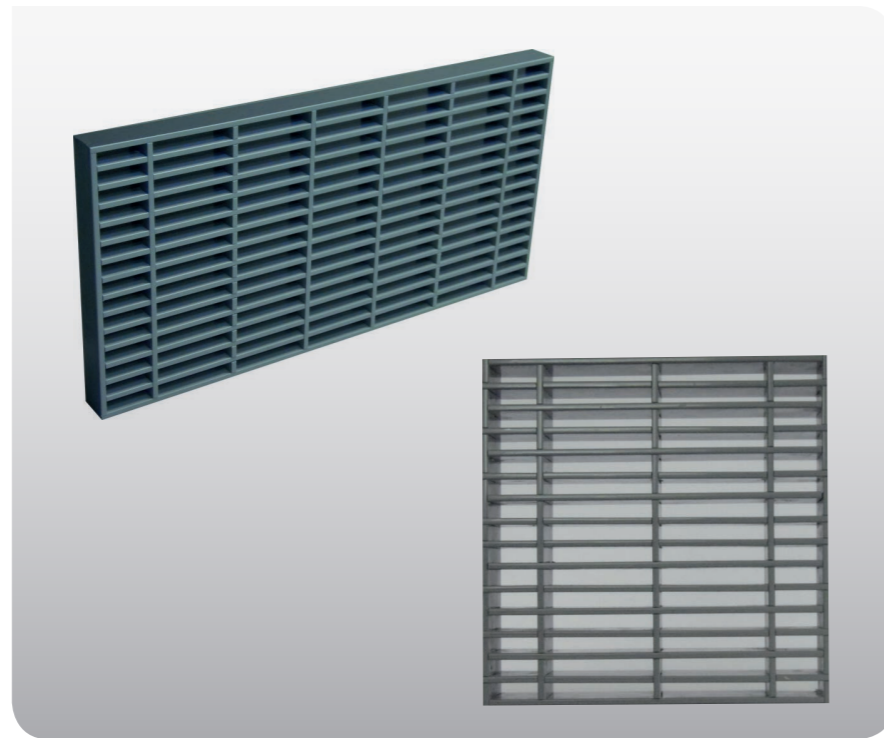

Product description

The intumescent grilles, KOOLAIR **LV** models, are used for compartmentation of small spaces that are designed for natural ventilation. Excellent air conduction characteristics, due to optimal noise levels in standard application. Two-way air flow. Easy to install. Free area equal to 60% of nominal area. Products for all applications: doors, walls, ducts, floors and ceilings. Full sealing achieved in about five minutes, as per BS 476: Pts 20 and 22 and UNE-EN 1634-1 2000.

Models

Resistance to fire and hot gases for up to 60 minutes.

LVV40. EI30/EI60 intumescent rectangular grille with straight fins and no frame.

LVC40. EI30/EI60 intumescent round grille with straight fins and no frame.

Resistance to fire and hot gases for up to 120 minutes.

LVH44. EI90/EI120 intumescent rectangular grille with straight blades and no frame.

LVHC44. EI90/EI120 intumescent round grille with straight blades and no frame.

Dimensions

LV and **LVH** rectangular models:
 Length: 100 to 600 mm
 Height: 100 to 600 mm

LVC and **LVHC** round models:
 Diameter: 100 mm to 600 mm (according to nominal diameter of standard PVC ducts or pipes).

General dimensions

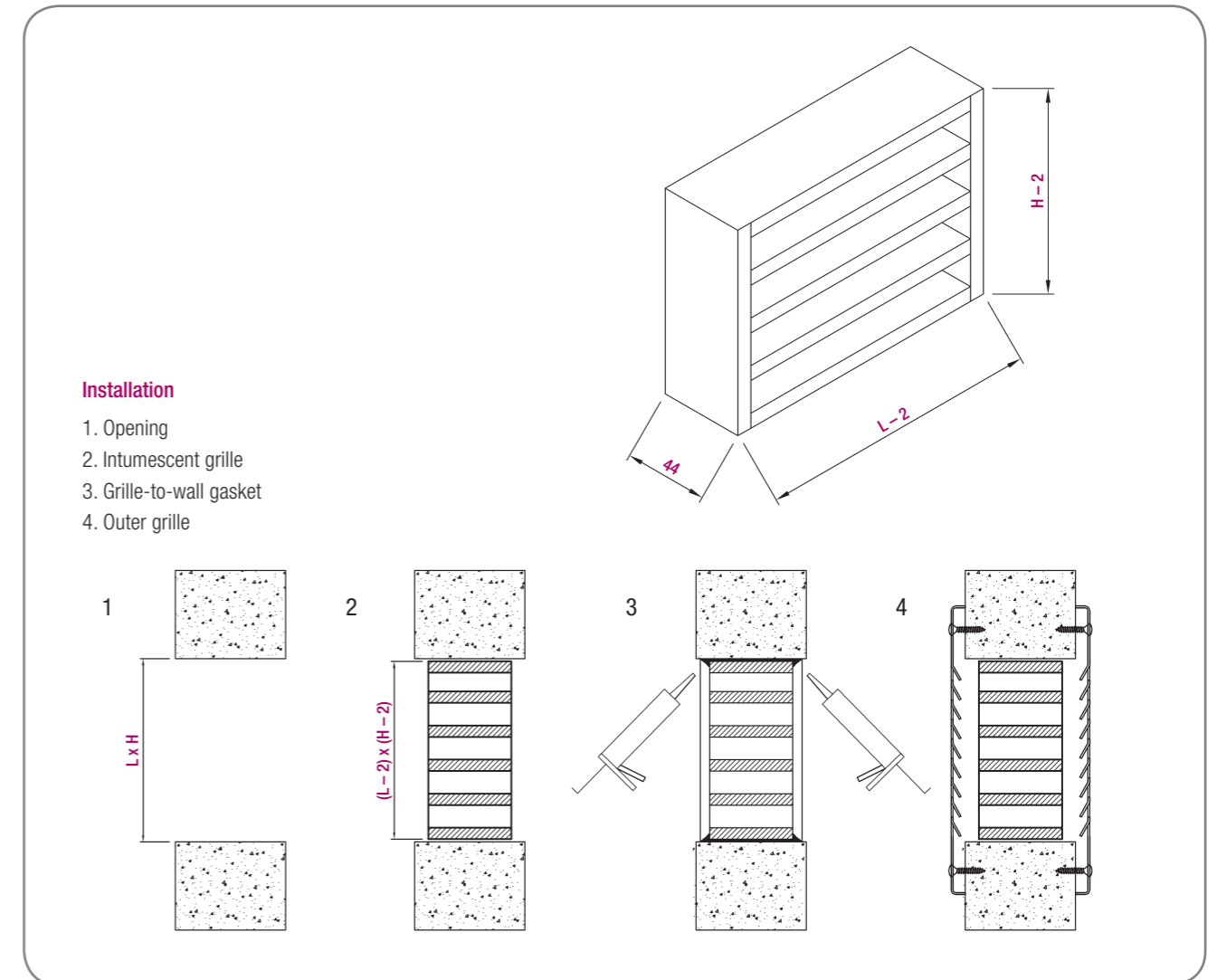



VAV/VAC



Archaeological Museum (Madrid – Spain)

Grille S-20, linear grille S-30,
linear floor grille 31-1-F,
swirl diffuser DFRO,
long-throw nozzle DF-49,
linear diffusers KLD, swirl floor diffuser DAFC-P
and boxes for variable air volume KS.

KS/KSL



Catalogue Series KS



Terminal unit VAV

Product description

Variable air volume terminal unit, KOOLAIR model **KS**, **KSL**, **KSR** & **KSLR** length dimension 610/1360mm respectively. Casing made in galvanised steel sheet, insulated thermo-acoustically with 30 mm fibreglass and black glass film. Equipped with volume control damper, differential pressure cross sensor and regulator-actuator motor, model to be advised. The insulation used is thermoacoustic, erosion resistant and environmentally friendly preventing the cultivation of microorganisms, and fire resistant, non-combustible M0. Can be equipped with a LPHW or Reheat battery and plenum box with multiple outlets. Especially designed for low ceiling void installations. Each can be used for supply or return air (**KSR**).

Other models

KS. Variable air volume terminal unit of length 610 mm.
KSL. Variable air volume terminal unit of length 1360 mm.
KSR. Variable air volume terminal unit of length 610 mm.
KSLR. Variable air volume terminal unit of length 1360 mm.

Accessories

Actuator/Regulator: Mention model, max & min project airflow. The minimum pressures for equipment setup depend on the actuator sensor accuracy.

Outlet plenum. Plenum with Multiple outlets available upon request (see catalogue C2 or visit our web-site).

W. LPHW low pressure hot water battery.
E. Reheat electric battery.

Note: Possibility of calibration and connecting for the implementation of constant flow and forced closure functions.

Dimensions

Nominal	A	B	Ø D
100	240	254	99
200	265	254	124
400	300	254	159
600	320	254	179
800	340	254	199
1200	420	254	249*
1600	520	254	314*
2000	585	254	354*
3000	655	254	399*
4000	735	254	499*
6000	710	458	499*
8000	915	458	629*

Unit mm
 * Oval spigot

Selection table

Size	Q (m³/h)	ΔP _{min} (Pa)	Regenerated noise Sound pressure L _{PA} dB(A)		Radiated noise Sound pressure L _{PA2} dB(A)	
			ΔP = 100 Pa	ΔP = 500 Pa	ΔP = 100 Pa	ΔP = 500 Pa
100	80	1	<20	26	<20	21
	400	6	31	43	28	39
200	125	1	<20	31	<20	22
	625	11	35	47	32	40
400	200	1	22	36	<20	23
	1000	16	38	51	33	41
600	275	1	25	39	<20	25
	1375	22	40	54	35	43
800	325	1	26	40	<20	25
	1625	23	41	55	35	43
1200	500	1	29	44	<20	26
	2500	27	43	58	36	45
1600	800	1	32	47	<20	28
	4000	33	45	60	38	47
2000	1000	1	33	48	20	29
	5000	34	40	61	39	48
3000	1250	1	24	50	21	29
	6250	36	47	62	40	48
4000	1700	1	27	51	22	31
	8500	45	48	63	42	50
6000	2000	1	28	52	23	31
	10000	44	47	63	47	51
8000	3250	1	37	54	25	34
	16250	50	48	64	44	53

LEGEND

Q (m³/h): Air flow.

L_{PA}: Sound pressure level of the regenerated noise, in dB(A), considering a room attenuation of 10 dB/oct.

L_{PA2}: Sound pressure level of the radiated noise, in dB(A), considering a room attenuation of 10 dB/oct.

ΔP_{min}: Minimal differential pressure in Pa.

ΔP = 100/500 Pa: Differential pressure in Pa (measured at the inlet and outlet of the unit).

General dimensions

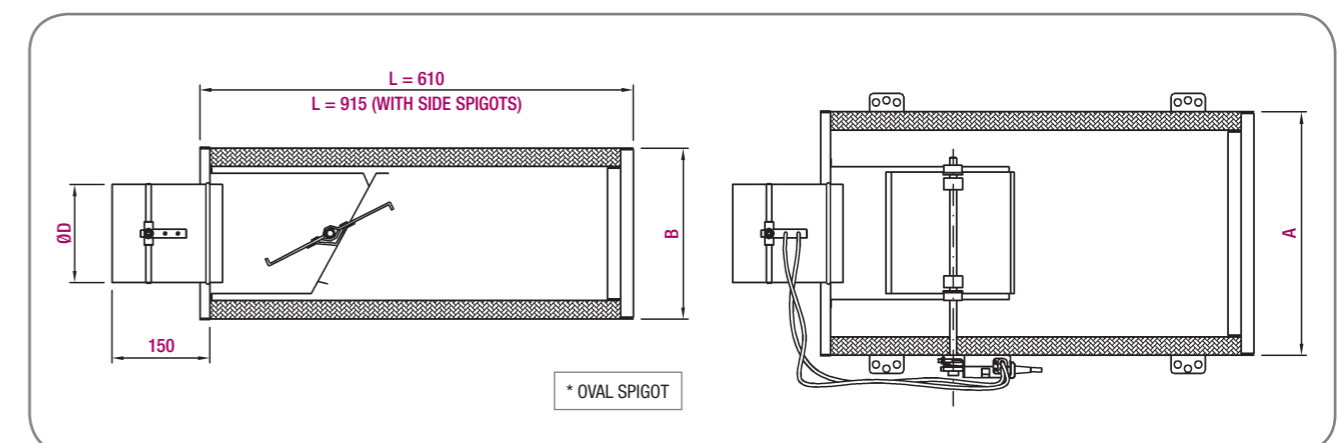

KSV/KSVL



Catalogue Series KSV



KSV with RCCK

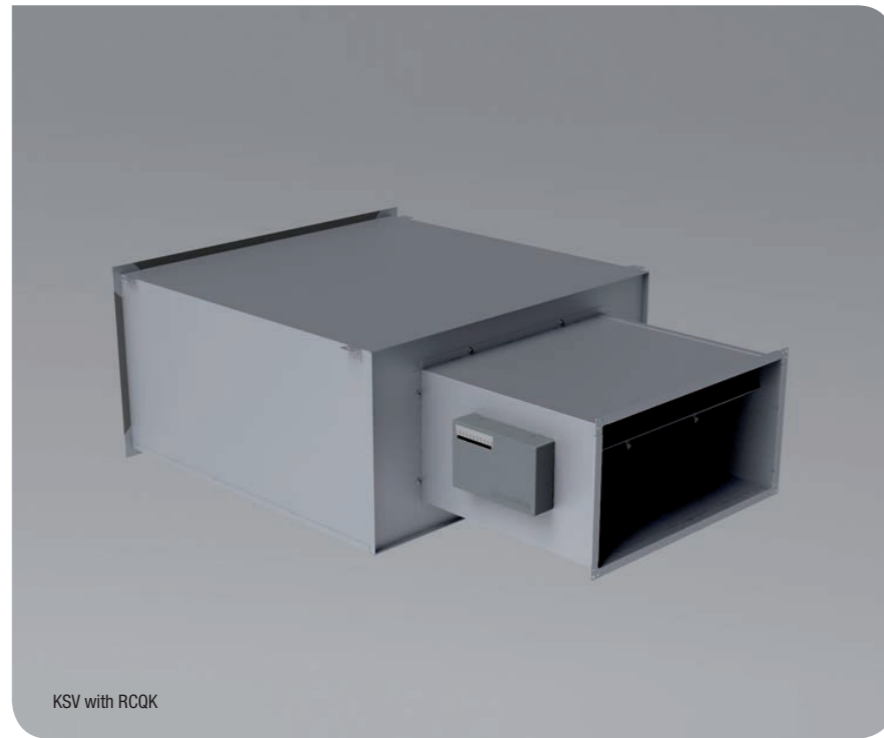

KSV with RCQK

Terminal unit VAC

Product description

Terminal control unit constant air flow, KOOLAIR brand, model **KSV / KSVL**, length dimension 610/1360 mm. Formed by a casing galvanized sheet steel, with internal insulation of thermoacoustic glass wool 30 mm thick coated with black fibre glass.

Regulator incorporates auto mechanic without need of external energy, ensuring a constant air flow independently of pressure variations suffered by the system. Provides the required flow rate with high accuracy, easily adjustable to any other volume requires on site.

Minimum required inlet pressure of 50 Pa. Material inside thermoacoustic high strength, not harmful to the health, prevents the cultivation of microorganisms and fire resistant, non-combustible M0.

Other models

KSV. Constant air volume terminal unit KSV of length 610 mm.

KSVL. Constant air volume terminal unit KSV of length 1360 mm.

Accessories

Outlet plenum. Plenum with Multiple outlets available upon request (see catalogue C2 or visit our web-site).

W. LPHW low pressure hot water battery.

E. Reheat electric battery.



General dimensions

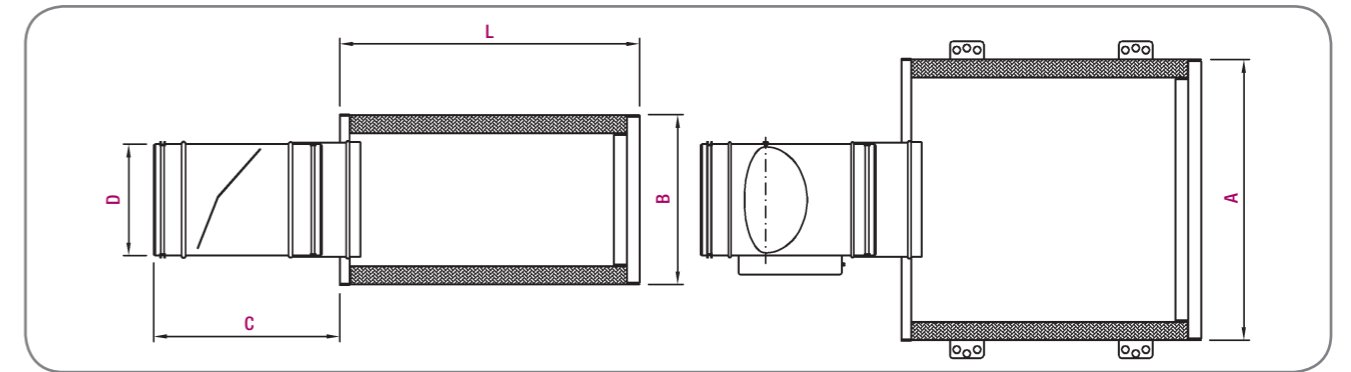

Type	A	B	C	D	L		KSVL
					Without lateral outlets	With lateral oval spigots	
100	240	254	480	Ø 100	610	915	1360
200	265			Ø 125			
400	300			Ø 160			
600	320			Ø 200			
800	340	485	485	200 x 200	610	915	1360
1200	420			300 x 200			
1600	520			400 x 200			
2000	585			500 x 200			
3000	655			600 x 200			

Unit mm

Selection table

Size	Q (m³/h)	ΔP _{min} (Pa)	Regenerated noise		Radiated noise	
			Sound pressure L _{PA} dB(A)		Sound pressure L _{PA2} dB(A)	
			ΔP = 100 Pa	ΔP = 500 Pa	ΔP = 100 Pa	ΔP = 500 Pa
100	80	50	<20	29	<20	<20
	325	50	21	38	<20	<20
200	135	50	<20	35	<20	<20
	500	50	26	44	<20	26
400	235	50	23	39	<20	<20
	850	50	33	49	<20	32
600	370	50	28	43	<20	<20
	1320	50	35	51	24	37
800	430	50	28	42	26	39
	1730	50	42	55	35	48
1200	530	50	33	46	27	42
	2160	50	45	58	37	52
1600	720	50	36	51	28	43
	2850	50	48	62	38	53
2000	880	50	33	49	26	40
	3600	50	42	57	35	50
3000	1080	50	32	47	26	41
	4320	50	42	56	35	50

LEGEND

Q (m³/h): Air flow.

L_{PA}: Sound pressure level of the regenerated noise, in dB(A), considering a room attenuation of 10 dB/oct.

L_{PA2}: Sound pressure level of the radiated noise, in dB(A), considering a room attenuation of 10 dB/oct.

ΔP_{min}: Minimal differential pressure in Pa.

ΔP = 100/500 Pa: Differential pressure in Pa (measured at the inlet and outlet of the unit).

KCRK



Catalogue Series KCRK



Constant air flow adjustment

Product description

Constant air flow adjustment, KOOLAIR **KCRK** model, of circular cross-section of size Ø_ for air supply or return.

Manufactured in ABS AF312A-class plastic material with flammability V0.

Automechanical, with no need for outside power, ensuring constant air flow regardless of the pressure variations experienced by the system. Housings and blade of high-quality plastic.

Minimum input pressure = 30 Pa (except Ø80 = 50 Pa).

Can be installed in horizontal or vertical position.



1. Body.
2. Blade.
3. Shock absorber.
4. Gasket.
5. Adjustment scale.

Range of air flows, m³/h

Size	1	2	3	4	5	6	7	8	9	10	11	12
80	22	30	37	45	55	70	85					
100	30	35	40	52	60	75	95	120				
125	40	47	56	67	77	89	110	130	150	192		
150	52	60	70	78	95	100	125	145	165	195	225	
160	61	72	81	96	117	133	154	180	210	245	282	
200	98	112	125	150	186	225	271	307	326	364	409	466
250	168	216	254	289	336	392	423	466	500	559	613	723

General dimensions

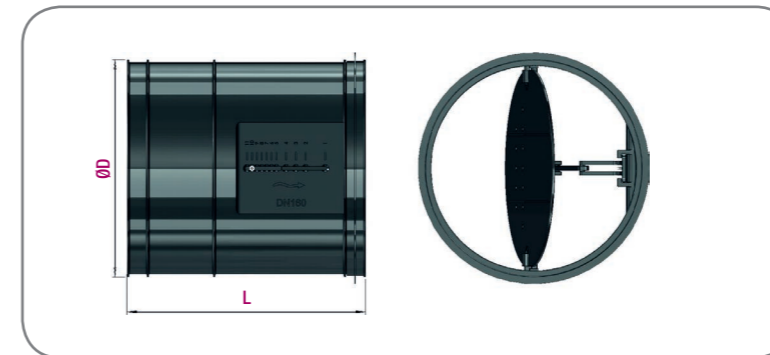

Dimensions

Size	Ø D (mm)	L (mm)	M (kg)
80	78	94	0,07
100	98	113	0,12
125	122	145	0,18
150	146	160	0,27
160	156	171	0,3
200	196	201	0,49
250	246	242	0,8

Unit mm

Installation requirements

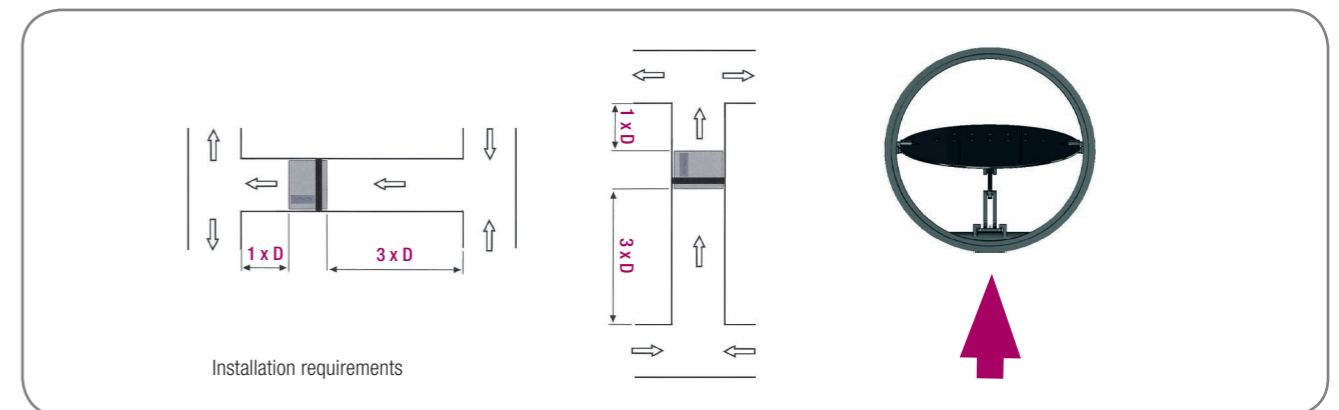

Selection table

Size	Q (m ³ /h)	Regenerated noise Sound pressure L _{pa} dB(A)			
		ΔP = 50 Pa	ΔP = 100 Pa	ΔP = 150 Pa	ΔP = 200 Pa
80	22	28	34	37	40
	55	30	35	39	41
	85	30	36	39	42
100	30	27	34	38	40
	52	29	36	39	42
	120	32	38	42	45
125	40	27	34	39	42
	89	29	37	41	44
	192	32	39	44	47
150	52	26	33	37	40
	100	28	35	39	42
	225	31	38	42	45
160	61	27	35	40	43
	145	29	37	41	45
	282	30	38	43	46
200	98	26	35	40	43
	225	28	37	42	45
	466	30	38	43	47
250	168	25	33	38	41
	392	27	35	40	43
	723	28	36	41	44



LEGEND

Q (m³/h): Air flow..
 L_{pa}: Sound pressure level of the regenerated noise, in dB(A), considering a room attenuation of 10 dB/oct.
 ΔP = 50/200 Pa: Differential pressure in Pa (measured at the inlet and outlet of the unit).

RCCK



Catalogue Series RCC



Constant Air Volume Regulator

Product description

Constant air volume circular regulator, Koolair model **RCCK**, for use in supply or extract systems. The unit is self regulating and will operate independent of pressure variations within the system.

Casing and damper blade are manufactured from galvanised sheet steel. Air flow rate is factory set, and the unit is easily adjustable on site to a high rate of accuracy. Minimum inlet pressure required is 50 Pa.

Can be mounted either horizontally or vertically. Can be supplied with 50 mm of thermoacoustic insulation (**RCCK-D**).

Option to include circular silencer to attenuate regenerated noise in flow rate regulator (**RCCK + ASK**).

The constant volume flow controller, model **RCCK**, meets the specifications set out in EN 1751, obtaining class "C" (optional) air tightness for the casing of the controller.

Models

RCCK. Constant Volume circular regulator without insulation equipped with adjustment mechanism box.
RCCK-D. Constant Volume circular regulator with insulation equipped with adjustment mechanism box.
RCCK-MT. Uninsulated mechanical circular constant flow regulator with electric servomotor (All-or-Nothing-Control or 0-10V).
RCCK-D-MT. Insulated mechanical circular constant flow regulator with electric servomotor (ON-OFF Control or 0-10V).

Installation requirements

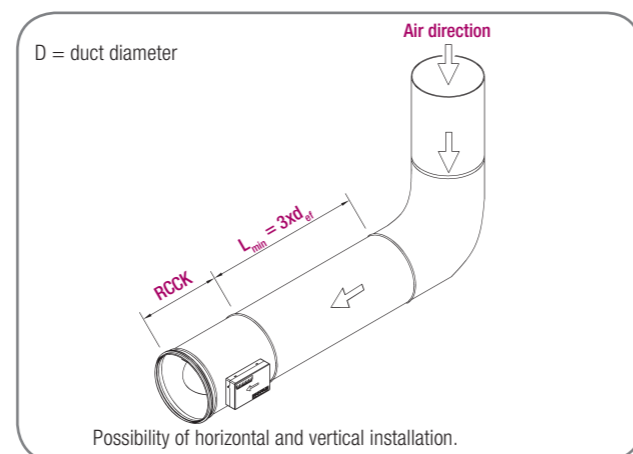

General dimensions

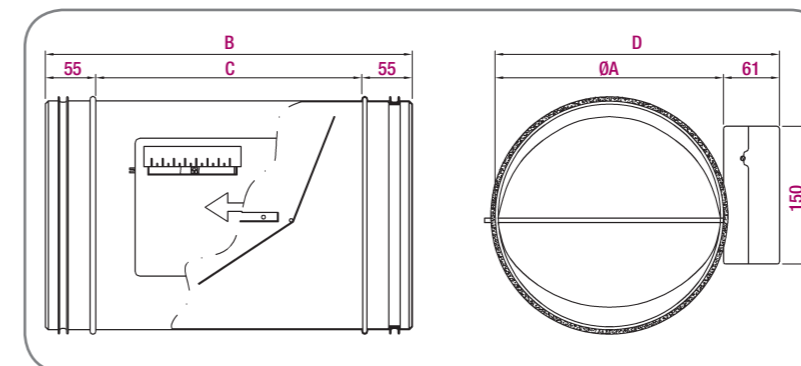

Model	Ø A	B	C	D
80	78			139
100	98			159
125	123			184
160	158	400	290	219
200	198			259
250	248			309
315	313			374
355	353	450	340	414
400	398			459

Unit mm

Selection table

Size	Q (m³/h)	ΔP _{min} (Pa)	Regenerated noise Sound pressure L _{pa} dB(A)		Radiated noise Sound pressure L _{pa2} dB(A)	
			ΔP = 100 Pa	ΔP = 500 Pa	ΔP = 100 Pa	ΔP = 500 Pa
80	40	50	25	38	<20	33
	100	50	31	44	22	38
	140	50	33	46	24	40
100	80	50	30	42	<20	34
	200	50	36	48	23	39
	300	50	38	51	26	41
125	135	50	33	46	<20	33
	325	50	39	52	24	39
	500	50	42	54	27	42
160	235	50	36	49	<20	33
	520	50	42	55	25	39
	800	50	45	58	28	42
200	370	50	38	52	20	34
	820	50	43	57	26	40
	1375	50	46	60	30	43
250	520	50	37	53	21	33
	1300	50	42	57	28	41
	2100	50	44	60	32	44
315	865	50	42	56	23	35
	2050	50	46	60	30	42
	3300	50	48	62	34	46
355	1000	50	42	55	23	35
	2500	50	47	60	31	43
	4000	50	50	63	35	47
400	1200	50	43	56	24	35
	3150	50	49	62	32	44
	5000	50	52	65	36	48

LEGEND

Q (m³/h): Air flow.
L_{pa}: Sound pressure level of the regenerated noise. in dB(A). considering a room attenuation of 10 dB/oct.
L_{pa2}: Sound pressure level of the radiated noise. in dB(A). considering a room attenuation of 10 dB/oct.
ΔP_{min}: Minimal differential pressure in Pa.
ΔP = 100/500 Pa: Differential pressure in Pa (measured at the inlet and outlet of the unit).

RCQK



Catalogue Series RCC



Constant Air Volume Regulator

Product description

Constant air volume rectangular regulator, Koolair model **RCQK**, for use in supply or extract systems. The unit is self regulating and will operate independent of pressure variations within the system. Casing and damper blade are manufactured from galvanised sheet steel. Air flow rate is factory set, and the unit is easily adjustable on site to a high rate of accuracy. Minimum inlet pressure required is 50 Pa.

Can be mounted either horizontally or vertically. Can be supplied with 50 mm of thermoacoustic insulation (**RCQK-D**).

Option to include square silencer to attenuate regenerated noise in regulator (**RCQK + PAK**).

The constant volume flow controller, model **RCQK**, meets the specifications set out in EN 1751, obtaining class "C" (optional) air tightness for the casing of the controller.

Models

RCQK. Constant Volume rectangular regulator without insulation equipped with adjustment mechanism box.

RCQK-D. Constant Volume rectangular regulator with insulation equipped with adjustment mechanism box.

RCQK-MT. Uninsulated mechanical rectangular constant flow regulator with electric servomotor (All-or-Nothing-Control or 0-10V).

RCQK-D-MT. Insulated mechanical rectangular constant flow regulator with electric servomotor (ON-OFF Control or 0-10V).

General dimensions

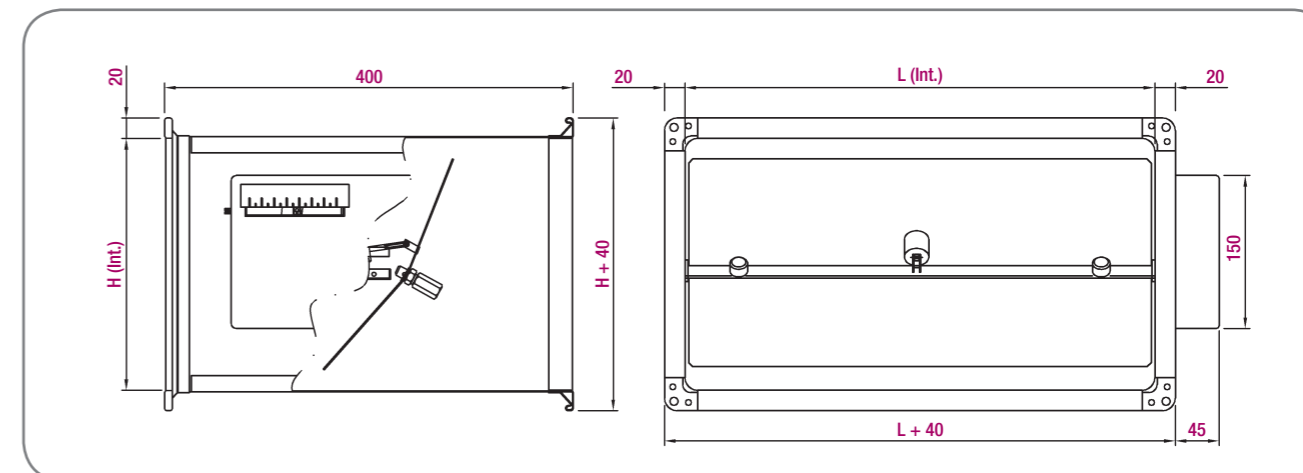

Dimensions Type 1

Model (L x H)	Model (L x H)
200 x 100	400 x 300
200 x 200	500 x 200
300 x 100	500 x 250
300 x 150	500 x 300
300 x 200	600 x 200
400 x 200	600 x 250
400 x 250	600 x 300

Unit mm

Dimensions Type 2

Model (L x H)	Model (L x H)
400 x 400	600 x 400
500 x 400	600 x 500
500 x 500	

Unit mm

Dimensions Type 3

Model (L x H)	600 x 600

Unit mm

Installation requirements

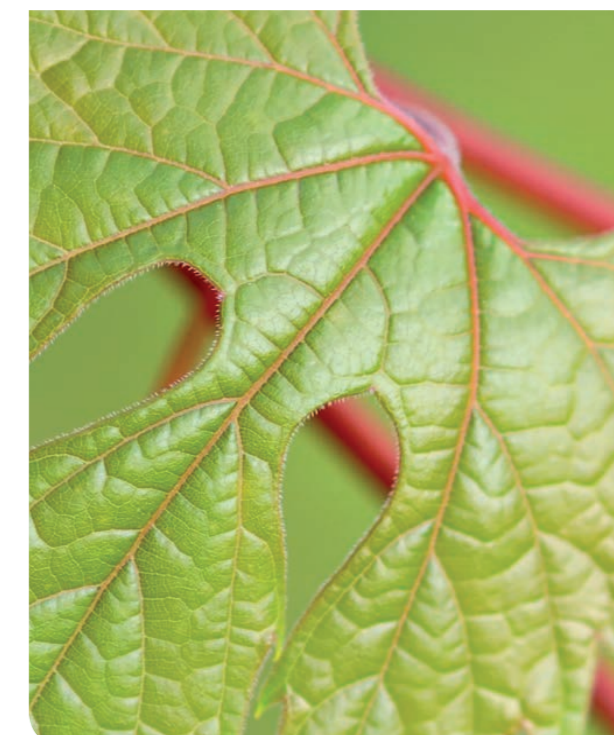
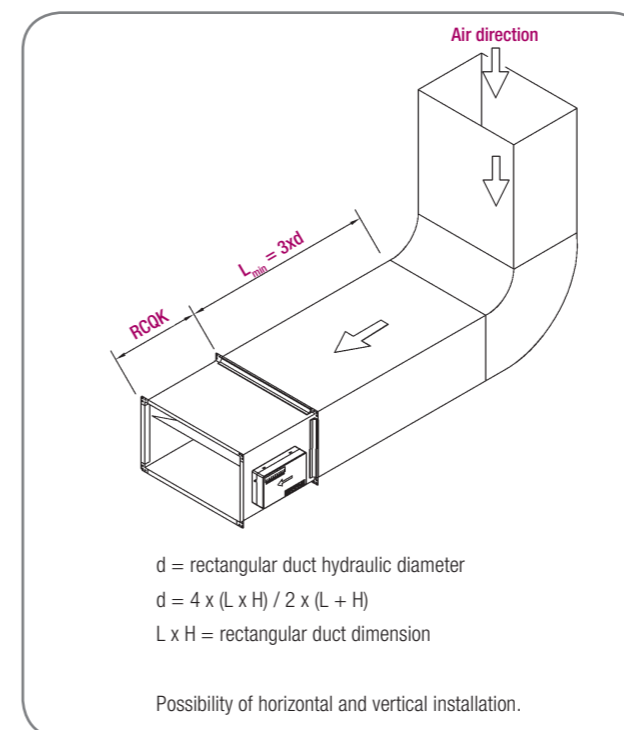

RCQK

Selection table

Size	Q (m³/h)	ΔP_{min} (Pa)	Regenerated noise		Radiated noise	
			Sound pressure L_{PA} dB(A)		Sound pressure L_{PA2} dB(A)	
			$\Delta P = 100$ Pa	$\Delta P = 500$ Pa	$\Delta P = 100$ Pa	$\Delta P = 500$ Pa
200 x 100	170	50	28	44	<20	30
	370	50	34	50	20	36
	600	50	37	53	23	39
200 x 200	350	50	33	49	<20	35
	830	50	40	56	26	42
	1600	50	43	59	29	45
300 x 100	260	50	31	47	<20	33
	590	50	37	53	23	39
	900	50	40	56	26	42
300 x 150	375	50	34	50	20	36
	1030	50	41	57	27	43
	1600	50	45	61	31	47
300 x 200	450	50	35	51	21	37
	1340	50	43	59	29	45
	1850	50	46	62	32	48
400 x 200	800	50	42	57	28	45
	1800	50	45	60	31	46
	2900	50	47	62	33	48
400 x 250	830	50	42	57	28	43
	2220	50	45	61	31	47
	3100	50	47	62	33	48
400 x 300	1200	50	33	50	<20	36
	2730	50	42	59	28	45
	4500	50	48	65	34	51
400 x 400	1600	50	44	60	30	47
	3640	50	51	67	37	53
	5800	50	55	71	41	57

LEGEND

Q (m³/h): Air flow.
 L_{PA} : Sound pressure level of the regenerated noise. in dB(A). considering a room attenuation of 10 dB/oct.
 L_{PA2} : Sound pressure level of the radiated noise. in dB(A). considering a room attenuation of 10 dB/oct.
 ΔP_{min} : Minimal differential pressure in Pa.
 $\Delta P = 100/500$ Pa: Differential pressure in Pa (measured at the inlet and outlet of the unit).

Selection table

Size	Q (m³/h)	ΔP_{min} (Pa)	Regenerated noise		Radiated noise	
			Sound pressure L_{PA} dB(A)		Sound pressure L_{PA2} dB(A)	
			$\Delta P = 100$ Pa	$\Delta P = 500$ Pa	$\Delta P = 100$ Pa	$\Delta P = 500$ Pa
500 x 200	850	50	42	57	28	43
	2240	50	46	61	32	47
	3300	50	47	63	33	49
500 x 250	1075	50	34	50	20	36
	2810	50	44	61	30	47
	4000	50	48	65	34	51
500 x 300	1400	50	43	59	29	45
	3380	50	50	67	36	53
	5300	50	55	71	41	57
500 x 400	2100	50	43	59	29	46
	4500	50	48	65	34	53
	6300	50	51	67	37	57
600 x 200	950	50	30	47	<20	33
	2325	50	41	57	27	43
	3700	50	46	62	32	48
600 x 250	1200	50	41	58	27	44
	3220	50	50	66	36	52
	4600	50	53	70	39	56
600 x 300	1550	50	41	57	27	43
	4050	50	48	64	34	50
	5700	50	50	66	36	52
600 x 400	2140	50	43	59	29	45
	4770	50	49	65	35	51
	7400	50	52	68	38	54
600 x 600	3300	50	46	62	32	48
	8100	50	52	69	38	55
	11600	50	55	71	41	57

LEGEND

Q (m³/h): Air flow.
 L_{PA} : Sound pressure level of the regenerated noise. in dB(A). considering a room attenuation of 10 dB/oct.
 L_{PA2} : Sound pressure level of the radiated noise. in dB(A). considering a room attenuation of 10 dB/oct.
 ΔP_{min} : Minimal differential pressure in Pa.
 $\Delta P = 100/500$ Pa: Differential pressure in Pa (measured at the inlet and outlet of the unit).



RVV



Catalogue Series RVV

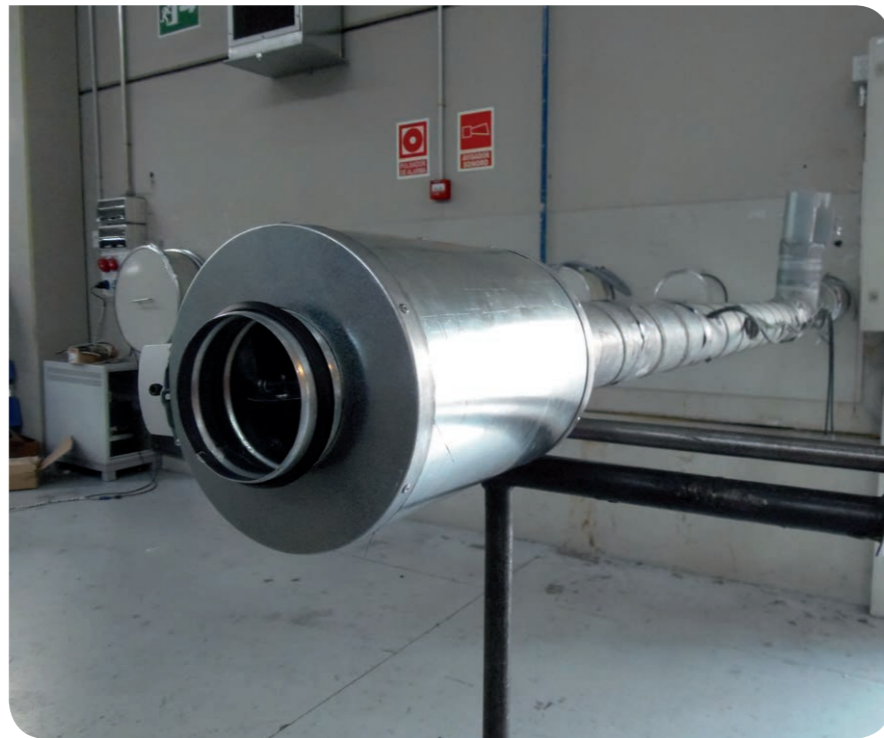

Variable Air Volume Regulator

Product description

Circular Variable Air Volume regulator, KOOLAIR brand, model **RVV**, size Ø_, incorporating an elliptical regulating damper with gasket in its perimeter cruciform sensor measuring differential pressure and proportional actuator, upper and lower limits to be calibrated in factory. RVV variable volume regulator is suitable for both supply and return work, they can incorporate thermal and sound insulation (**RVV-D**). Option to include circular silencer to attenuate regenerated noise in flow rate regulator (**RVV + ASK**).

The variable volume flow controller, model **RVV**, meets the specifications set out in EN 1751, obtaining class "C" (optional) air tightness for the casing of the controller.

Models

RVV. Circular Variable Air Volume regulator.

RVV-D. Circular Variable Air Volume regulator with Thermoacoustic insulation 50mm thickness.

RVV-DL. Circular Variable Air Volume regulator with Thermoacoustic insulation 50mm thickness and enlarge casing.

Accessories

Actuator/Servomotor. Maximum and minimum air-flow must be indicated, as well as actuator brand/model. The minimum pressures for equipment setup depend on the actuator sensor accuracy.

Note: Possibility of calibration and connecting for the implementation of constant flow and forced closure functions.

General dimensions

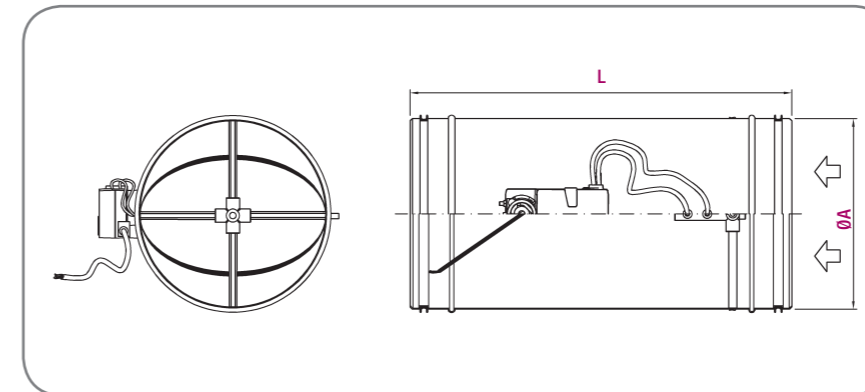

Nominal	Ø A	L	
		RVV	RVV-L
80	78	340	690
100	98		
125	123	365	730
160	158	400	800
200	198	440	880
250	248	490	980
315	313	555	1000
355	353	595	
400	398	640	
450	448	690	
500	498	740	
630	628	870	

Unit mm

Selection table

Size	Q (m³/h)	ΔP _{min} (Pa)	Regenerated noise		Radiated noise	
			Sound pressure L _{PA} dB(A)		Sound pressure L _{PA2} dB(A)	
			ΔP = 100 Pa	ΔP = 500 Pa	ΔP = 100 Pa	ΔP = 500 Pa
80	18	2	21	27	<20	29
	162	76	43	49	25	40
	270	210	49	55	27	42
100	28	1	21	30	<20	27
	255	69	44	51	24	38
	425	191	50	56	26	41
125	44	1	<20	25	<20	25
	390	58	45	52	23	38
	650	161	51	57	26	40
160	72	1	24	35	<20	24
	645	50	46	53	23	37
	1075	140	51	58	27	41
200	110	3	32	40	<20	25
	1020	43	46	54	24	38
	1700	121	51	59	28	42
250	175	2	32	40	<20	25
	1575	34	46	54	24	39
	2625	96	51	59	28	43
315	280	2	32	41	<20	26
	2520	27	46	54	26	41
	4200	74	50	59	30	45
400	450	1	31	41	<20	28
	4050	18	44	54	29	43
	6750	50	49	58	33	48

Note: Technical data given are for ours RVV & RVV-D.

LEGEND

Q (m³/h): Air flow.

L_{PA}: Sound pressure level of the regenerated noise, in dB(A), considering a room attenuation of 10 dB/oct.

L_{PA2}: Sound pressure level of the radiated noise, in dB(A), considering a room attenuation of 10 dB/oct.

ΔP_{min}: Minimal differential pressure in Pa.

ΔP = 100/500 Pa: Differential pressure in Pa (measured at the inlet and outlet of the unit).

RVV-Q



Catalogue Series RVV-Q/JVR



Variable Air Volume Regulator

Product description

Rectangular Variable Air Volume regulator, KOOLAIR brand, model **RVV-Q**, size LxH, incorporating regulating damper with gasket in its perimeter cruciform sensor measuring differential pressure and proportional actuator, upper and lower limits to be factory calibrated. RVV variable volume regulator is suitable for both supply and return work, they may incorporate thermal and sound insulation (**RVV-Q-D**). Option to include square silencer to attenuate regenerated noise in regulator (**RVV-Q + PAK**).

The variable volume flow controller, model **RVV-Q**, meets the specifications set out in EN 1751, obtaining class "C" (optional) air tightness for the casing of the controller.

Models

- RVV-Q.** Rectangular Variable Air Volume regulator.
- RVV-Q-D.** Rectangular Variable Air Volume regulator with Thermoacoustic insulation 50 mm thickness.
- RVV-Q-DL.** Rectangular Variable Air Volume regulator with Thermoacoustic insulation 50 mm thickness and enlarge casing.

Accessories

Actuator/Servomotor. Maximum and minimum air-flow must be indicated, as well as actuator brand/model. The minimum pressures for equipment setup depend on the actuator sensor accuracy.

Note: Possibility of calibration and connecting for the implementation of constant flow and forced closure functions.

General dimensions

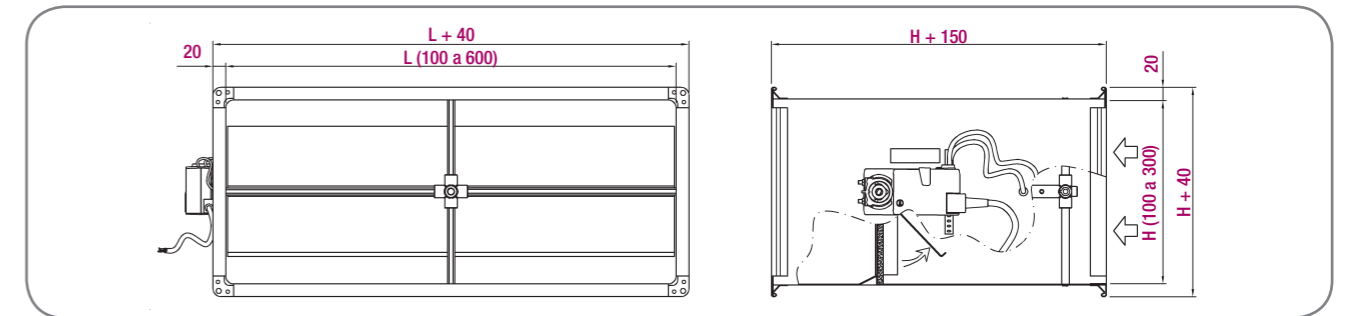

Minimum dimension from 200x100 to 1000x300 in steps of 50 mm.

Selection table

Size	Q (m ³ /h)	ΔP_{\min} (Pa)	Regenerated noise Sound pressure L_{PA} dB(A)		Radiated noise Sound pressure L_{PA2} dB(A)	
			$\Delta P = 100$ Pa	$\Delta P = 500$ Pa	$\Delta P = 100$ Pa	$\Delta P = 500$ Pa
200 x 100	72	1	26	40	11	25
	360	19	42	56	29	43
	720	75	49	63	38	52
200 x 200	144	1	30	44	16	30
	720	11	45	59	35	48
	1440	46	51	65	48	61
300 x 200	216	1	32	46	19	32
	1080	9	46	60	39	53
	2160	35	52	66	57	71
300 x 300	324	1	34	47	22	35
	1620	7	47	60	46	59
	3240	26	53	66	58	71
400 x 200	288	1	33	47	21	34
	1440	7	47	60	44	57
	2880	28	52	66	56	69
400 x 300	432	1	34	48	23	36
	2160	5	47	60	53	66
	4320	21	53	66	58	72
500 x 200	360	1	34	47	22	35
	1800	6	47	60	48	61
	3600	24	53	66	54	67
500 x 300	540	1	35	48	25	38
	2700	5	47	60	53	66
	5400	18	52	65	59	72
600 x 200	432	1	34	48	23	36
	2160	5	47	60	53	66
	4320	21	53	66	58	71
600 x 250	540	1	35	48	25	38
	2700	5	47	60	53	66
	5400	18	52	65	59	72
600 x 300	648	1	35	48	26	39
	3240	4	47	60	50	63
	6480	16	52	65	59	71

LEGEND

- Q (m³/h): Air flow.
- L_{PA} : Sound pressure level of the regenerated noise, in dB(A), considering a room attenuation of 10 dB/oct.
- L_{PA2} : Sound pressure level of the radiated noise, in dB(A), considering a room attenuation of 10 dB/oct.
- ΔP_{\min} : Minimal differential pressure in Pa.
- $\Delta P = 100/500$ Pa: Differential pressure in Pa (measured at the inlet and outlet of the unit).

JVR



Catalogue Series RVW-Q/JVR



Variable Air Volume Regulator

Product description

Variable Air Volume regulator KOOLAIR brand, model **JVR** of rectangular section has a wide range of sizes from 200x100 to 1200x1050 mm **JVR** body incorporates an air inlet connection equipped with a cruciform sensor to measure differential pressure and aerodynamic opposed blade regulating damper. **JVR** includes internal airtight seals around its perimeter to ensure excellent tightness.

Aerodynamic opposed blade are operated by a gear mechanism to achieve proper friction **JVR** can be fitted with fibreglass thermal-acoustic insulation internally (**JVR-DS**) upon request.

Option to include square silencer to attenuate regenerated noise in regulator (**JVR + PAK**).

The variable volume flow controller, model **JVR**, meets the specifications set out in EN 1751, obtaining class "C" (optional) air tightness for the casing of the controller.

Models

JVR. Rectangular Variable Air Volume regulator.

JVR-DS. Rectangular Variable Air Volume regulator with Thermoacoustic insulation 50 mm thickness.

Accessories

Actuator/Servomotor. Maximum and minimum air-flow must be indicated, as well as actuator brand/model. The minimum pressures for equipment setup depend on the actuator sensor accuracy.

Note: Possibility of calibration and connecting for the implementation of constant flow and forced closure functions.

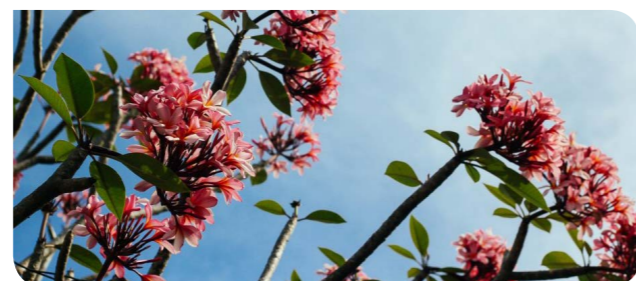

KOOLAIR

General dimensions

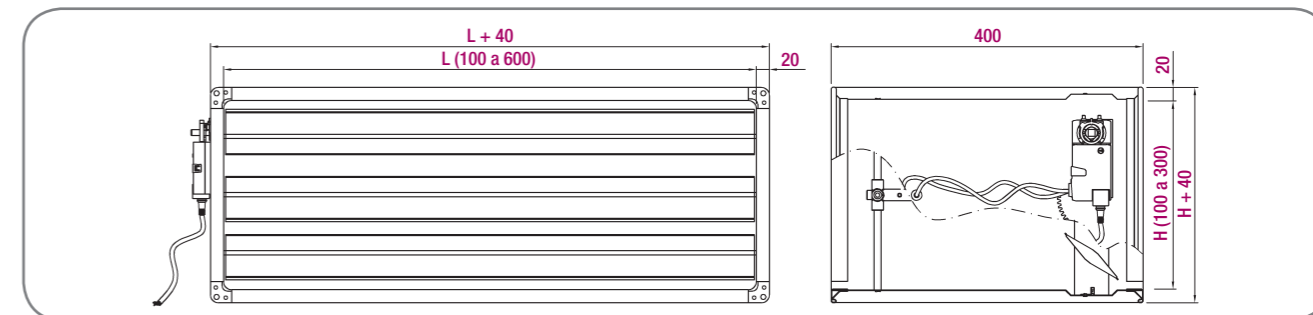

Minimum dimension from 200x200 to 1200x1050 in steps of 50 mm.

Selection table

Size	Q (m³/h)	ΔP _{min} (Pa)	Regenerated noise Sound pressure L _{PA} dB(A)		Radiated noise Sound pressure L _{PA2} dB(A)	
			ΔP = 100 Pa	ΔP = 500 Pa	ΔP = 100 Pa	ΔP = 500 Pa
400 x 400	576	1	37	50	27	40
	2880	4	49	62	50	63
	5760	17	54	67	55	68
500 x 500	900	1	37	50	30	43
	4500	3	48	61	53	66
	9000	13	53	66	58	70
600 x 600	1296	1	37	49	34	46
	6480	2	47	60	51	64
	12960	10	52	64	56	68
700 x 500	1260	1	37	49	33	46
	6300	3	47	60	49	62
	12600	10	52	65	54	67
700 x 600	1512	1	36	49	36	48
	7560	2	47	59	51	63
	15120	9	51	64	55	68
700 x 700	1764	1	36	49	32	44
	8820	2	46	59	51	63
	17640	8	51	63	55	67
800 x 500	1440	1	37	49	35	48
	7200	2	47	60	51	64
	14400	9	51	64	56	68
800 x 600	1728	1	36	49	38	51
	8640	2	46	59	51	63
	17280	8	51	63	56	68
800 x 800	2304	1	36	48	45	58
	11520	2	45	58	49	61
	23040	7	49	62	54	66
1000 x 600	2160	1	36	48	32	45
	10800	2	45	58	48	60
	21600	7	50	62	54	66
1000 x 1000	3600	1	34	46	31	43
	18000	1	43	55	48	60
	36000	5	47	59	52	64

LEGEND

Q (m³/h): Air flow.

L_{PA}: Sound pressure level of the regenerated noise, in dB(A), considering a room attenuation of 10 dB/oct.

L_{PA2}: Sound pressure level of the radiated noise, in dB(A), considering a room attenuation of 10 dB/oct.

ΔP_{min}: Minimal differential pressure in Pa.

ΔP = 100/500 Pa: Differential pressure in Pa (measured at the inlet and outlet of the unit).

Acoustics

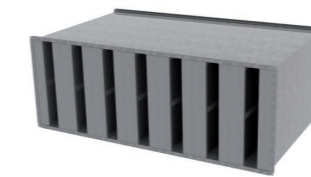

PAK (228)



KAT-Z (232)

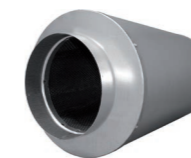

ASK-1 (229)

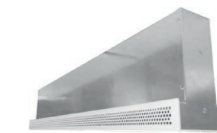

KAT-T (232)



250-TAA (229)

Ortiz Building (Madrid – Spain)

Grille 20-45-H,
linear floor grille 31-15-F,
linear grille 31-1,
long-throw nozzle DF-49,
linear diffusers S-74-25,
circular floor swirl diffusers DSA-S,
extract valves GPD and 46-SV,
dampers for round duct CCC,
boxes for variable air volume KSL
and fire dampers SFR2 and SFC2.



Circular silencers

Circular silencers KOOLAIR brand, model **ASK-1** (without core) or **ASK-2** (with core). The acoustic material comprises glass fibre density suitable for heat resistant and protected against erosion by perforated sheet galvanized plate. For the construction of the central core (ASK-2) are used the same materials. The maximum recommended temperature is 135° C.

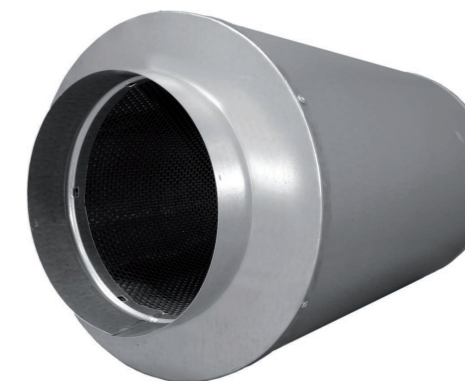

Rectangular silencers

Rectangular acoustic silencers, Koolair brand, model **PAK, PBK, PAKM** and **PBKM**. Box of galvanized sheet steel. Designed to be installed in areas where the air distribution needs a low noise level, for the attenuation up to 50 dB (A) according to the selected model. The acoustic material is glass fibre heat-resistant and protected against erosion by the air layer of protection against fire: PAK. If in addition it incorporates perforated plate: PBK (suitable for high velocities). With further coating of a polyester film: PAKM and PBKM. The maximum recommended temperature is 135° C.



Acoustic external Louvre

External acoustic louvre, Koolair brand, model **250-TAA** (single thickness) and **250-TAAD** (double thickness). Galvanized steel plate. Are used by introduction of fresh air or exhaust air discharge with attenuation of the initial noise level up to 20 dB (A) in the band of 250 Hz. The acoustic material is glass fibre heat-resistant and protected against erosion of the air by a perforated plate on the other side of the blades. The maximum recommended temperature is 135° C. Can incorporate bird-mesh (standard finish) or anti-insect mesh (on request).



Note: For more information refer to catalogue and/or Technical Department.

Note: For more information refer to catalogue and/or Technical Department.

ASK-1

Selection table

Dimension ØA	Q _{min} (m³/h)	Q _{max} (m³/h)	ΔP _{min} (Pa)	ΔP _{max} (Pa)
80	69	206	7	67
100	109	326	6	54
125	171	513	5	43
160	282	847	4	34
180	358	1075	3	30
200	443	1330	3	28
250	696	2087	2	22
315	1108	3324	2	18
355	1409	4228	2	17
400	1792	5375	2	15
450	2270	6810	2	14
500	2805	8415	1	12
560	3521	10564	1	11
630	4460	13381	1	10
710	5669	17007	1	9
800	7202	21606	1	8
900	9120	27361	1	7
1000	11265	33794	1	7



LEGEND

Q_{min} (m³/h): Air flow for a duct velocity of 4 m/s
 Q_{max} (m³/h): Air flow for a duct velocity of 12 m/s
 ΔP (Pa): Total pressure loss.

Attenuation. 500mm length

Dimension	f _m in Hz							
	63	125	250	500	1k	2k	4k	8k
80	5	9	12	14	28	44	35	24
100	4	7	10	13	27	43	34	23
125	4	7	10	13	27	42	22	11
160	4	7	9	12	25	35	18	10
180	4	7	9	11	24	30	16	10
200	3	5	6	11	24	24	15	9
250	3	5	6	9	22	19	13	9
315	2	4	5	8	15	15	9	8
355	2	4	5	8	14	14	9	8
400	2	4	5	7	13	13	8	7
450	2	4	5	7	11	12	7	7
500	2	3	4	7	8	7	6	5

Unit mm
 f_m (Hz): Octave band frequency.

Attenuation. 1000mm length

Dimension	f _m in Hz							
	63	125	250	500	1k	2k	4k	8k
80	6	13	19	27	47	50	50	36
100	5	11	17	26	46	50	50	35
125	5	10	15	24	44	50	39	21
160	5	9	13	21	41	48	28	17
180	5	9	13	20	40	43	26	17
200	4	7	11	18	39	33	22	14
250	4	6	10	15	36	26	18	14
315	3	6	8	16	30	21	13	12
355	3	5	7	14	27	20	12	11
400	3	5	6	14	27	19	11	11
450	3	5	5	14	18	19	11	11
500	2	5	5	12	17	13	10	8
560	2	5	5	12	17	12	10	7
630	1	4	5	11	16	11	8	5

Unit mm
 f_m (Hz): Octave band frequency.

PAK

Selection table

Dimension B x H	Q (m³/h)	V _f (m/s)	ΔP (Pa)
400 x 200	1200	4.2	18
400 x 300	1600	3.7	15
500 x 300	2200	4.1	18
500 x 400	2500	3.5	13
600 x 300	3000	4.6	23
600 x 400	4000	4.6	23
600 x 600	5000	3.9	16
800 x 500	6000	4.2	18
800 x 600	7000	4.1	17
900 x 600	8000	4.1	18
900 x 900	10000	3.4	12
1200 x 600	12000	4.6	23
1200 x 1200	18000	3.5	13
1500 x 1200	22500	3.5	13
1800 x 1500	25000	2.6	7
1800 x 1800	30000	2.6	7
2100 x 1500	40000	3.5	13
2100 x 1800	45000	3.3	12

LEGEND

Q (m³/h): Air flow.
 ΔP (Pa): Total pressure loss (L: 1000 mm).
 V_f (m/s): Air velocity based on BxH section.

Other models

PAK-H. Rectangular silencer for fancoil installation.



Attenuation. 600mm length

P	f _m in Hz							
	63	125	250	500	1k	2k	4k	8k
50	6	12	21	33	35	40	25	21
75	4	9	16	26	31	37	19	16
100	4	8	16	19	27	30	16	14
125	3	7	12	17	24	23	14	12
150	3	7	10	15	19	21	12	11
175	2	6	10	15	17	19	12	9
200	2	4	9	12	15	15	11	7

Attenuation. 1200mm length

P	f _m in Hz							
	63	125	250	500	1k	2k	4k	8k
50	10	21	41	50	50	50	45	31
75	7	15	31	50	50	50	43	31
100	6	12	28	40	50	50	35	26
125	5	11	25	35	45	47	28	21
150	5	11	20	34	38	40	28	20
175	4	10	18	27	36	37	25	18
200	3	9	17	23	30	31	22	17

Unit mm
 P: Airway in mm.
 f_m (Hz): Octave band frequency.

Note: The sound attenuation data provided corresponds to the use of 200 mm wide interior baffles.

KAT



Catalogue Series KAT

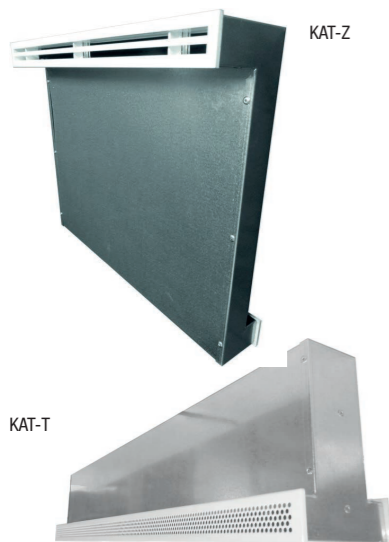

Sound attenuation air transfer units

Product description

The KAT sound attenuation air transfer units, KOOLAIR brand, model **KAT**, offers a high sound absorption level, low pressure loss, easy installation and attractive design. Air is moved to adjacent rooms by the transfer unit by the pressure difference between the rooms.

The unique design allows the unit to be installed in plasterboard walls for air movement between adjacent areas, while also avoiding vision through the device and ensuring room-to-room sound reduction to guarantee conversation privacy. The sound reduction of the equipment is independent of the wall material.

Plenum box in galvanised steel sheet. Diffusers and grilles in aluminium, anodized or painted in RAL color to be defined.

Models

KAT-Z. Sound attenuation air transfer units for wall thicknesses of 100 mm.

KAT-T. Sound attenuation air transfer units for wall thicknesses of 125 mm.

BAK. Acoustic box.

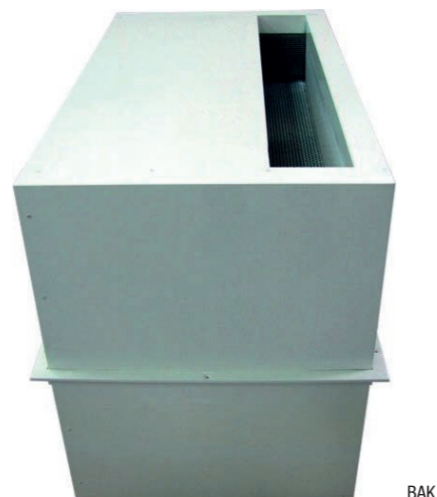

Note: For more information refer to catalogue and/or Technical Department.

KOOLAIR

General dimensions (KAT-Z)

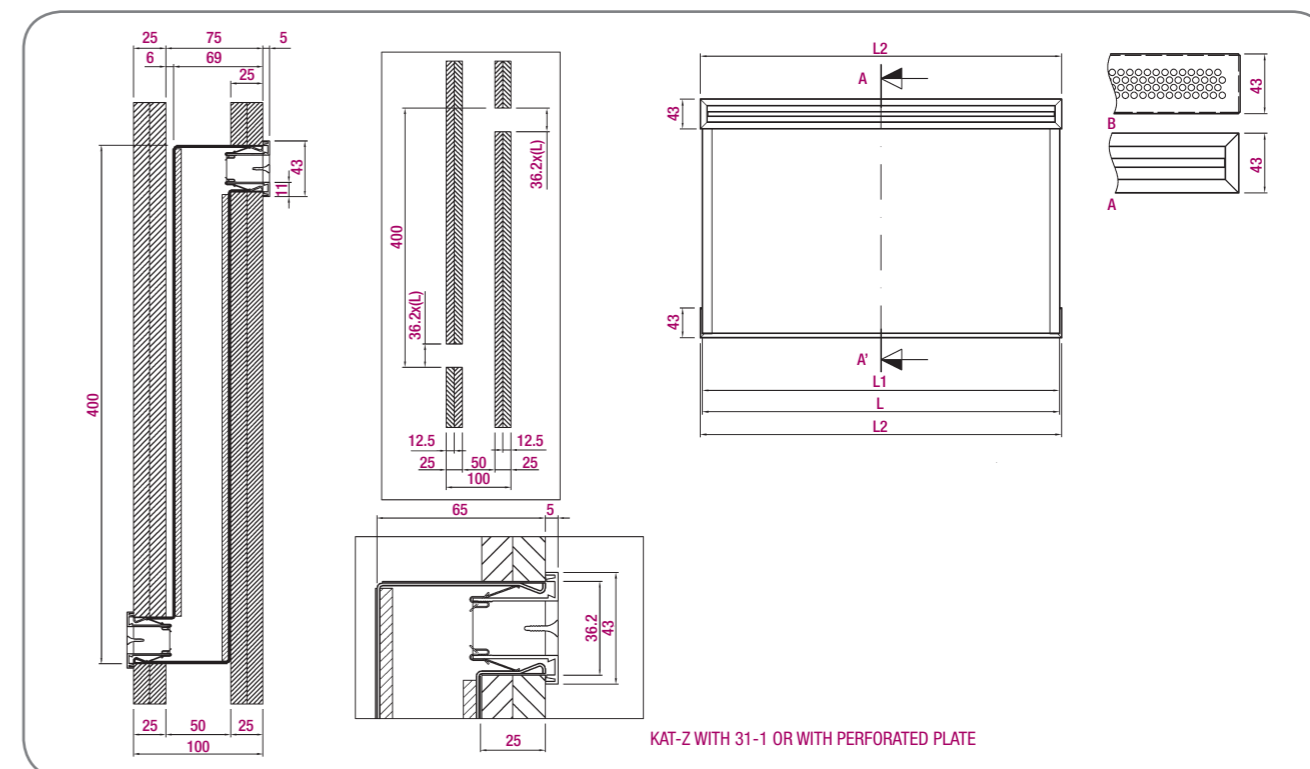

KAT-Z

L	L1	L2
500	499	508
1.000	999	1.008

Unit mm

KAT-T

L	L1	L2
500	499	508
1.000	999	1.008

Unit mm

General dimensions (KAT-T)

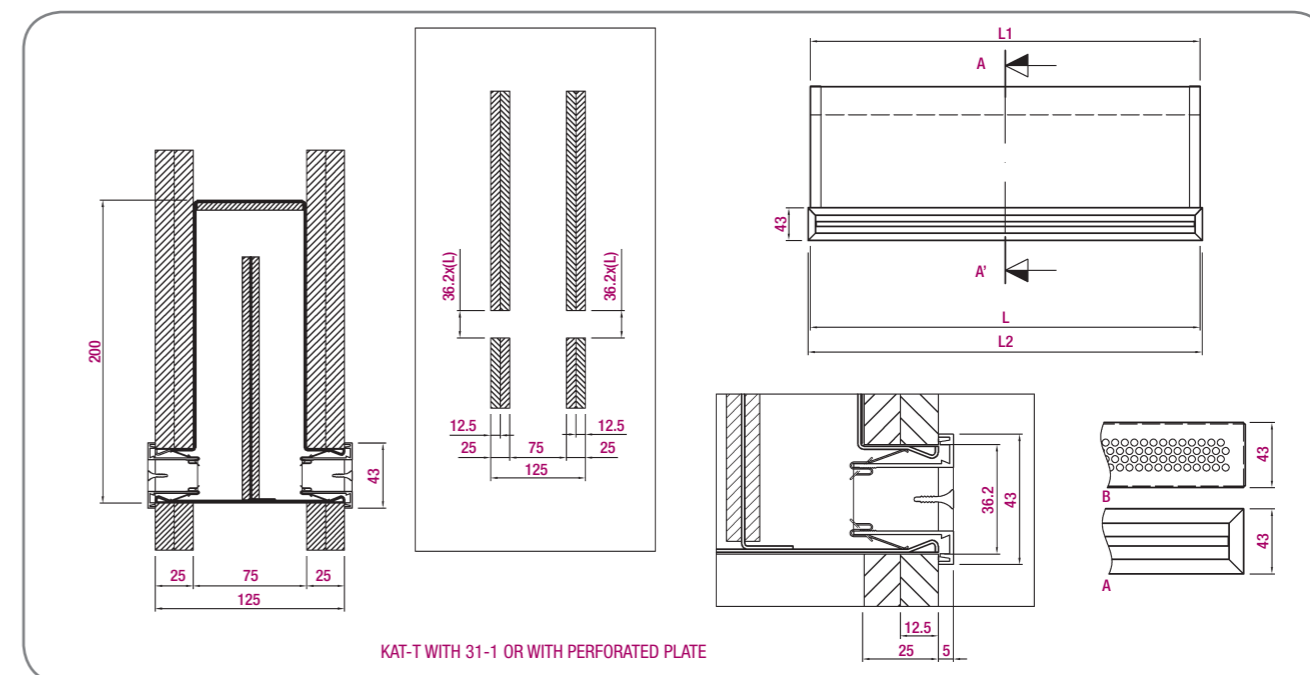

Air/Water



Titanic Building
(Belfast – United Kingdom)
Boxes for variable air volume KSL.

VFK-600



Catalogue Series VFK 600



Active chilled beam

Product description

Active chilled beam, KOOLAIR brand, model **VFK-600**, length L, width 600 mm and height 200 mm, integrated in the false ceiling or plasterboard. It incorporates 2 linear lateral side slot diffusers, with air deflector made in plastic raw material M1 (optional) for horizontal supply with Coanda effect of the mixed air flow (primary and secondary air). Hinged perforate plate face, available in different patterns to access the battery and get it cleaned. The unit is equipped internally with nozzles (size P/M/G) on both sides of the primary plenum box, incorporating as an option nozzle control system. Hot or chilled water (two-pipe installation), or hot and chilled water (four pipe installation) coil copper tubes and Aluminum fins and water connection dia 1/2". One or two air connections (front/side or top), Dia-124 mm.

VFK-600 is provided with hanging brackets to ease its installation. Standard finish RAL 9010, other finish available upon request. Optionally **VFK-600** can be equipped with control valve / balancing and dew point sensor. See website www.koolair.com & Komfortair-Water program for technical data.

Note: For more information refer to catalogue and/or Technical Department.

General dimensions

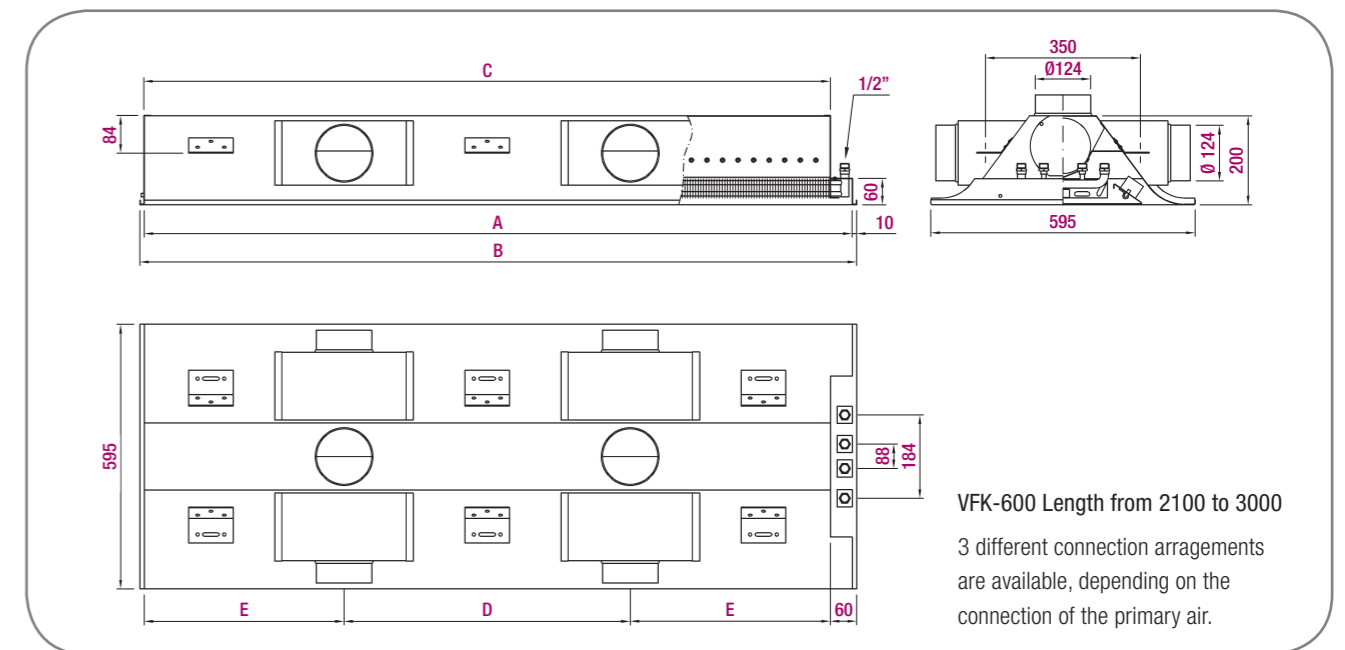
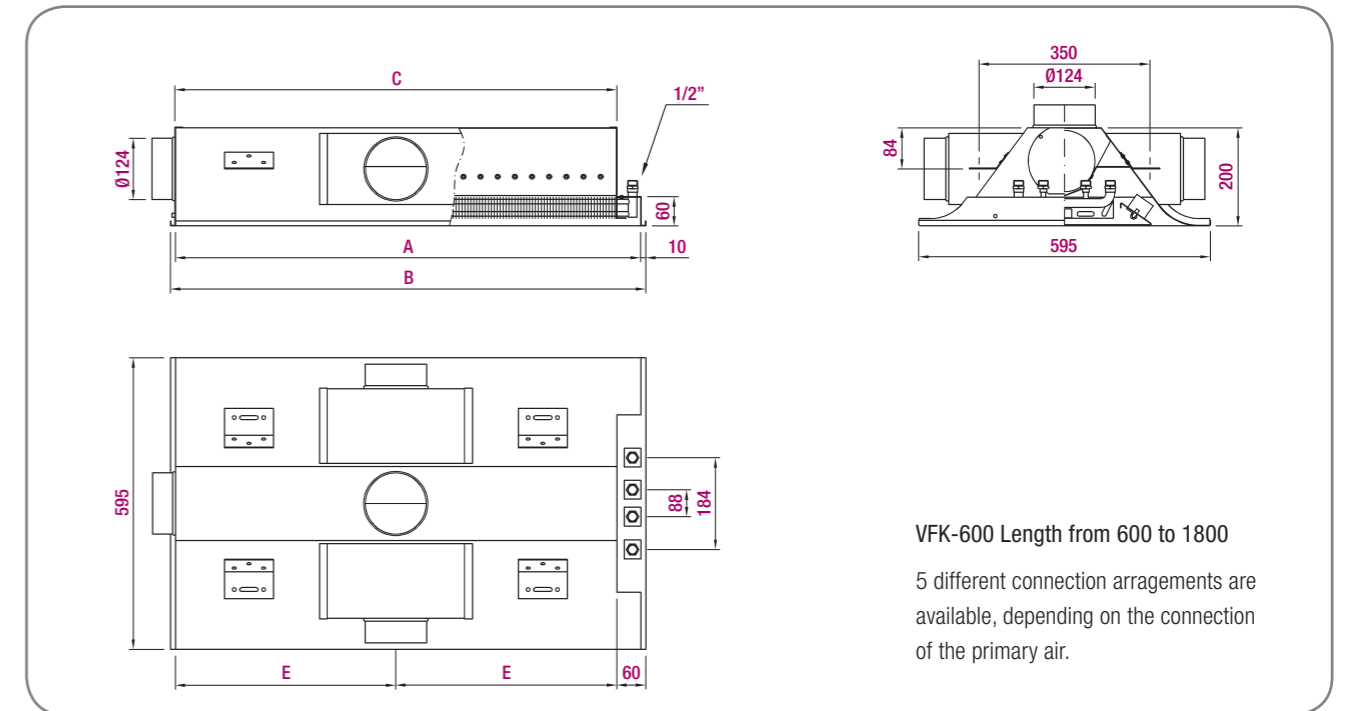

Size	A	B	C	E
600	572	592	522	261
900	872	892	822	411
1200	1172	1192	1122	561
1500	1472	1492	1422	711
1800	1772	1792	1722	861

Size	A	B	C	D	E
2100	2072	2092	2022	1011	506
2400	2372	2392	2322	1161	581
2700	2672	2692	2622	1311	656
3000	2972	2992	2922	1461	731

Unit mm

Unit mm

VFK-Q



Catalogue Series VFK-Q



Active chilled beam

Product description

Active chilled beam, KOOLAIR brand, model **VFK-Q**, length (600/1200), width 600 mm and height 200 mm, integrated in the false ceiling or plasterboard. It incorporates 4 linear slot diffusers, with air deflector made in plastic raw material M1 (optional) for horizontal supply with Coanda effect of the mixed air flow (primary and secondary air). Hinged perforate plate face, available in different patterns to access the battery and get it cleaned. The unit is equipped internally with nozzles (size P/M/G) on both sides of the primary plenum box, incorporating as an option nozzle control system. Hot or chilled water (two-pipe installation), or hot and chilled water (four pipe installation) coil copper tubes and Aluminum fins and water connection dia 1/2". One or two air connections (front/side or top), Dia-124 mm.

VFK-Q is provided with hanging brackets to ease its installation. Standard finish RAL 9010, other finish available upon request. Optionally **VFK-Q** can be equipped with control valve / balancing and dew point sensor. See website www.koolair.com & Komfortair-Water program for technical data.

Note: For more information refer to catalogue and/or Technical Department.

General dimensions

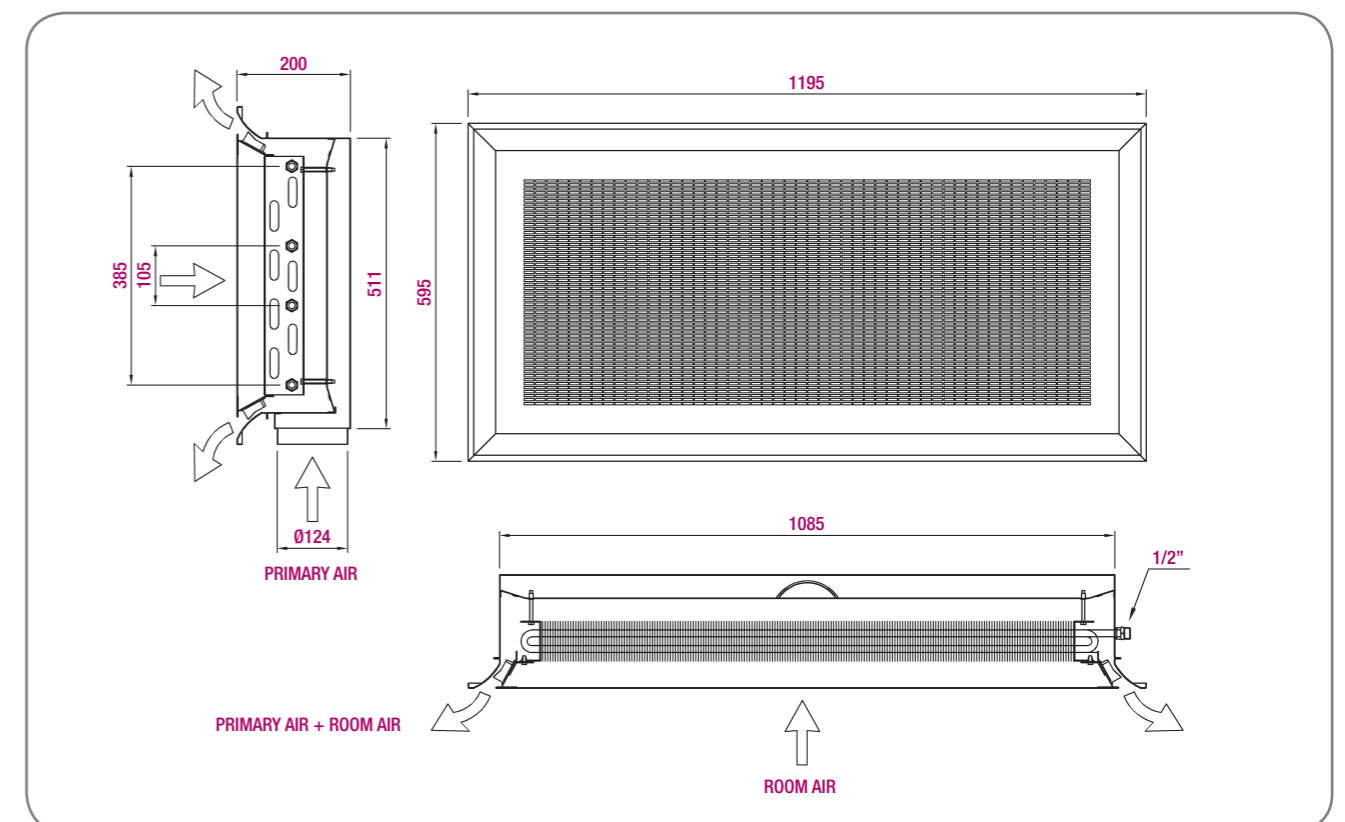
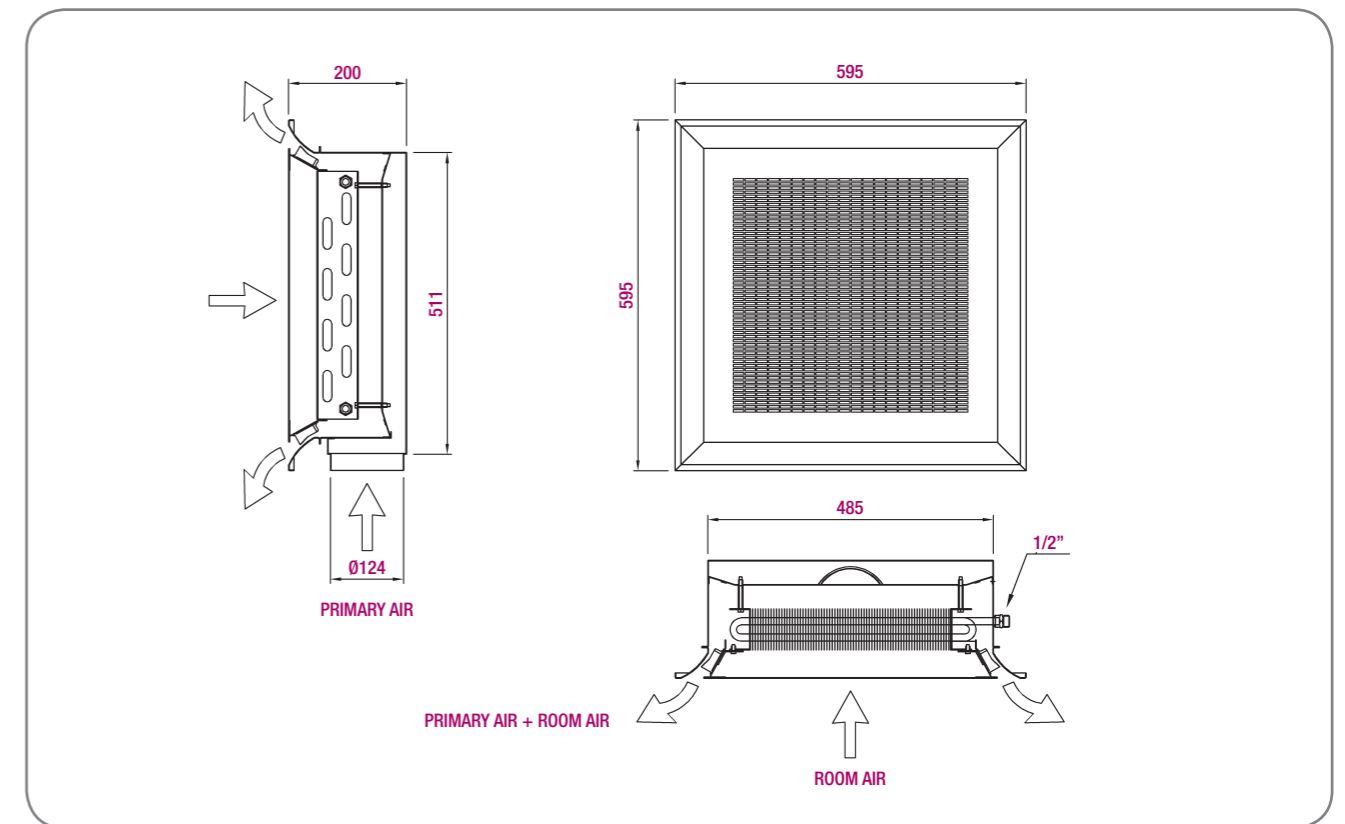

VFK-300



Catalogue Series VFK-300



Active chilled beam

Product description

Active chilled beam, KOOLAIR brand, model **VFK**, length from 600 to 3000, width 300 mm and height 200 mm, integrated in the false ceiling or plasterboard.

The unit incorporate a plenum of primary air, with one or two circular connections of the primary air and some nozzles; a chilled water battery (two-pipe installation) or chilled and hot water (four pipe installation); and linear diffusers, one on each side of the battery, for supplying and diffusing the mixed primary airflow and induced air.



Note: For more information refer to catalogue and/or Technical Department.

General dimensions

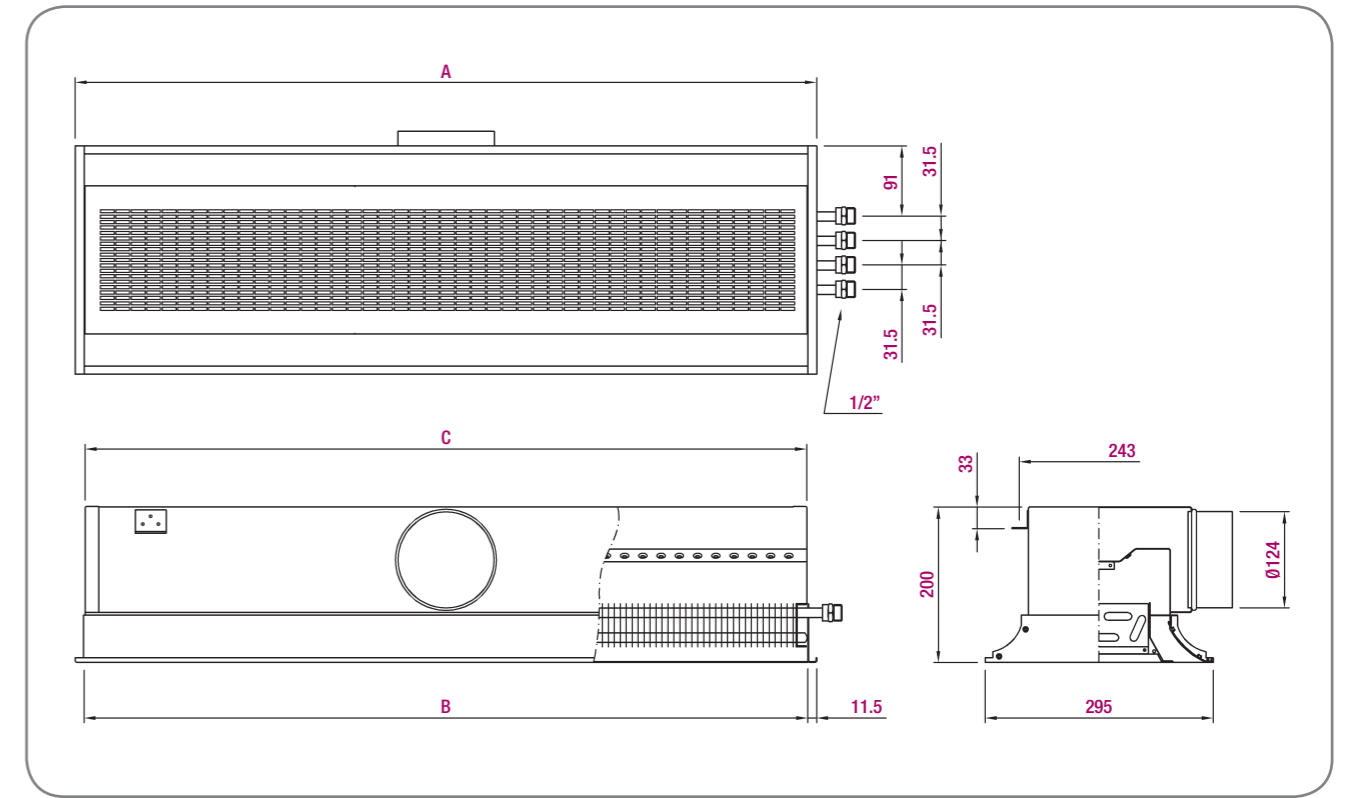

Size	A	B	C
900	895	872	874
1200	1195	1172	1174
1500	1495	1472	1474
1800	1795	1772	1774
2100	2095	2072	2074
2400	2395	2372	2374
2700	2695	2672	2674
3000	2995	2972	2974

Unit mm



IHK



Catalogue Series IHK



Inductor unit

Product description

Horizontal Inductor unit to supply air in one direction, **IHK** model, brand KOOLAIR, length (900/1200/1500) mm, width 700 mm and height 200 mm, for installation in false ceilings. Incorporates air discharge grille available in different designs, for horizontal air diffusion Coanda effect air mixture (primary and secundaro).

Induction grille available in different designs, hinged or removable for battery cleaning purpose. The unit integrates inner plenum nozzles (type P/M/G) for supply of primary air. Internal battery in horizontal position (2/4) pipes for cooling and / or heating with copper piping connections outside diameter 12 mm and aluminum finned pack.

Provided with a primary air connection Ø124 mm diameter front. Supply and return air grilles made of aluminum profiles, envelopes, inductor profiles manufactured entirely in galvanized steel.

Note: For more information refer to catalogue and/or Technical Department.

The unit is provided with fixing brackets. Standard finish RAL 9010 or grilles painted matte anodized aluminum.

Optionally **IHK** can be equipped with control valve / balancing and dew point sensor.

See website www.koolair.com & Komfortair-Water program for technical data.

KOOLAIR

General dimensions

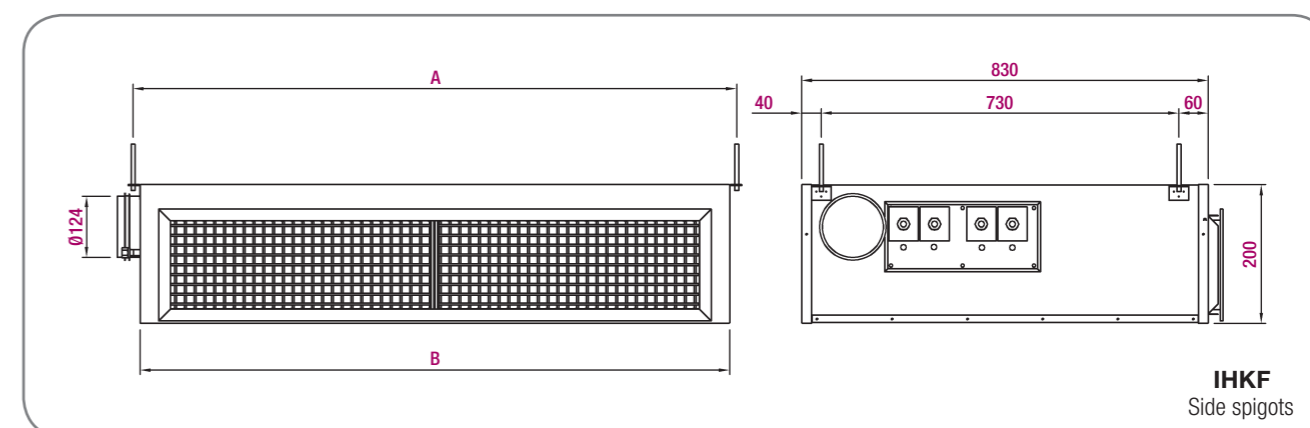
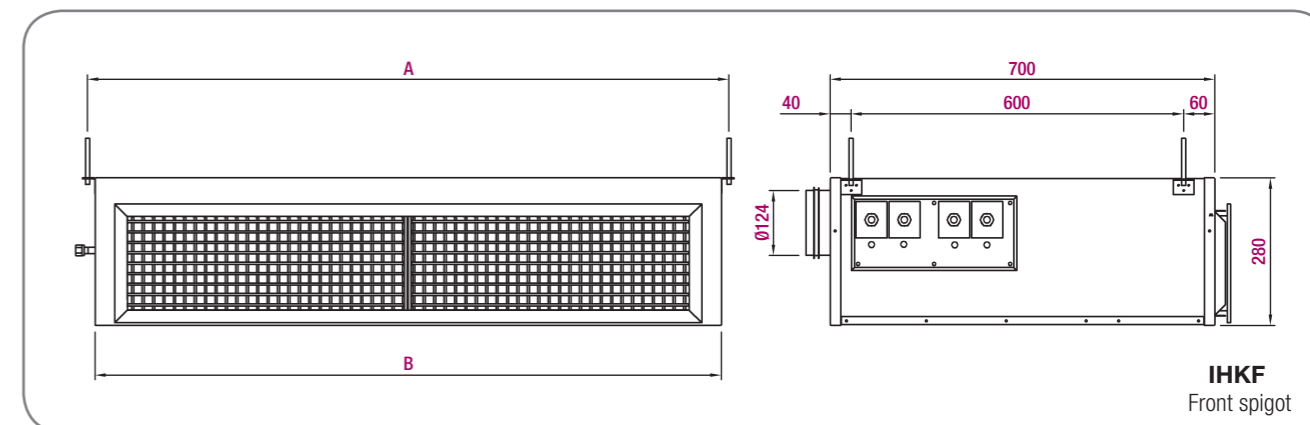
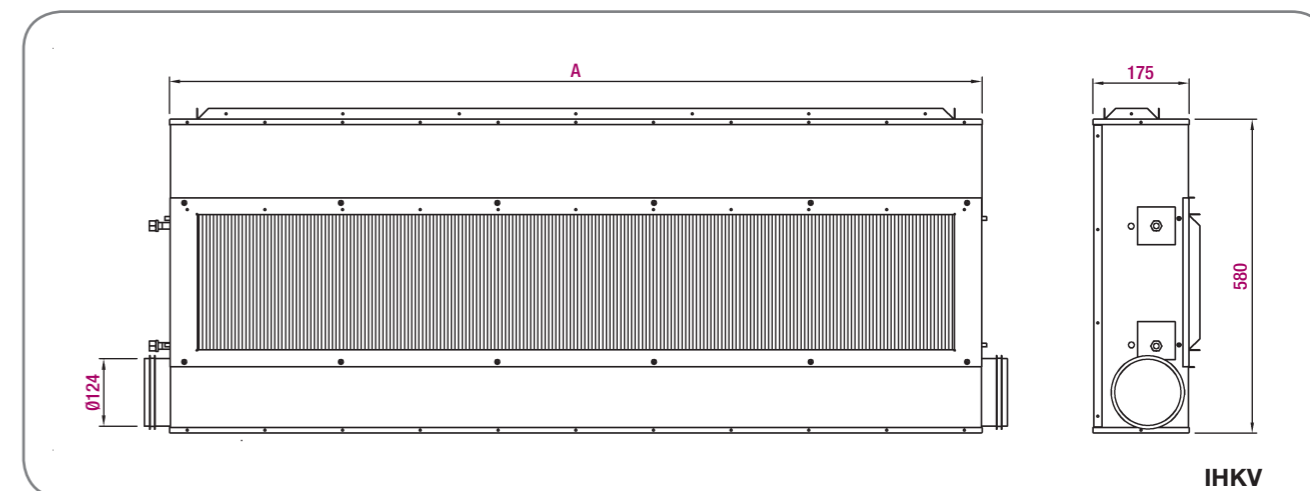

IHKV

Size	A
900	900
1200	1200
1500	1500

Unit mm

IHKF Front entry

Size	A	B
900	932	900
1200	1232	1200
1500	1532	1500

Unit mm

IHKF Side entry

Size	A	B
900	932	900
1200	1232	1200
1500	1532	1500

Unit mm

VPK



Catalogue Series VPK



Passive chilled beams

Product description

The ceiling-mounted terminal units known as passive chilled beams, **VPK** model, without air supply, are used to offset internal loads in an area. Passive chilled beams use water to carry cooling power to the various areas, which is an advantage, as the units save on energy and space, in comparison to all-air systems. Passive chilled beams may be installed flush with a drop ceiling or in a hanging position.

Models

VPK. Passive chilled beams with perforated plate.
VPK-E. Passive chilled beams without perforated plate.

Finished

The housing and perforated plate are manufactured from galvanized steel. The heat exchanger unit consists of copper pipes and an aluminium fin pack, with galvanized flanges. The standard surface finish is pure white (RAL 9010) with a powder finish. Both plate perforation and colours can be modified upon request. In addition, light fixtures, speakers, sprinklers, etc., may be installed in the beam.

General dimensions

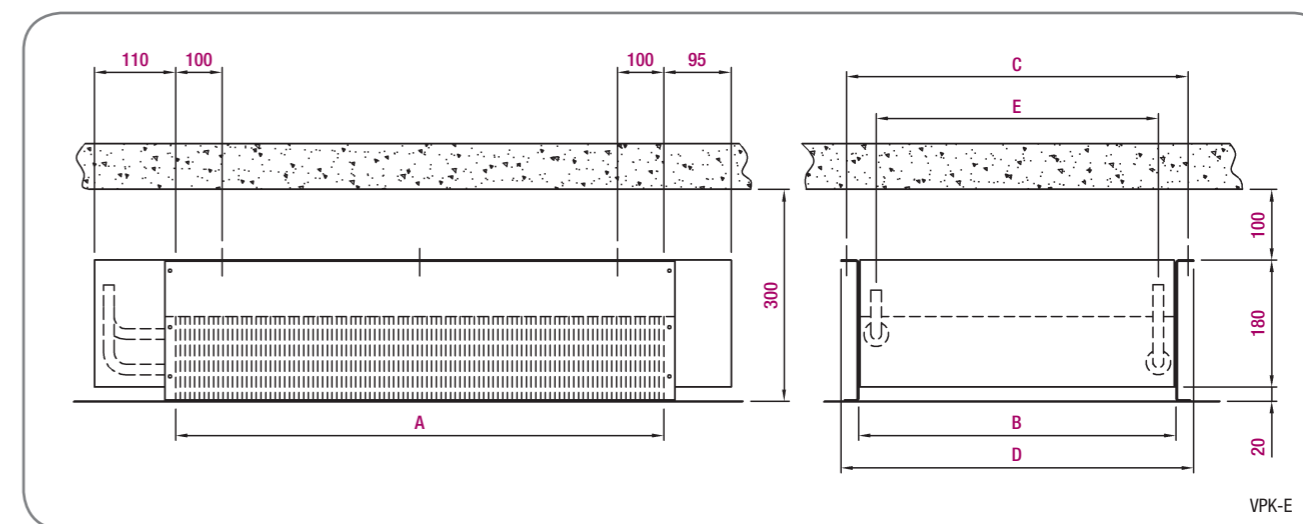
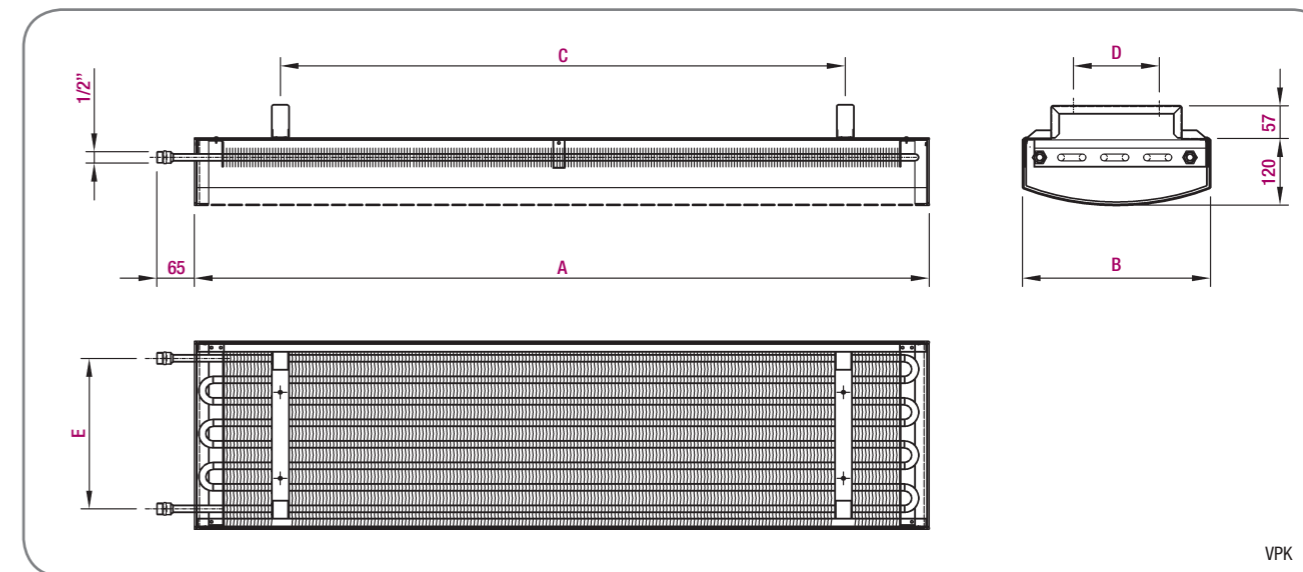

Model	A	B	C	D	E
VPK-120-330-900	900	330	600	150	263
VPK-120-330-1200	1200	330	900	150	263
VPK-120-330-1500	1500	330	1200	150	263
VPK-120-330-1800	1800	330	1500	150	263
VPK-120-330-2100	2100	330	2x900	150	263
VPK-120-330-2400	2400	330	2x1050	150	263
VPK-120-330-2700	2700	330	2x1200	150	263
VPK-120-330-3000	3000	330	2x1350	150	263

Unit mm

VPK-E

A	B	C	D	E
1500				
2000	320	354	370	270
2500				
3000				
1500				
2000	450	484	500	400
2500				
3000				
1500				
2000	600	634	650	550
2500				
3000				

Unit mm

Note: For more information refer to catalogue and/or Technical Department.

TFK



Catalogue Series TFK

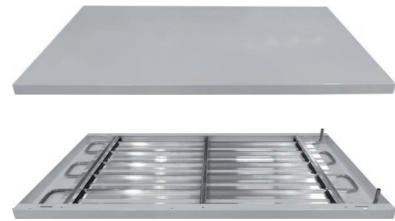

Chilled ceiling

Product description

The KOOLAIR **TFK** Chilled Ceiling modules are designed for use in open or grid ceilings. The **TFK** chilled ceiling modules (without primary air) are radiation systems that use water to carry cooling power to the various rooms, thus saving energy and space compared to all-air systems. These have the huge advantage of chilling, while avoiding air currents in the room. Can be used for heating purposes. When installed in an open grid ceiling, the free surface of the module must be as large as possible to ensure that the chilled ceiling does not lose efficiency.

Models

TFK. Smooth plate.
TFK-P. Microperforated plate.

Finished

Plate manufactured from galvanized steel. Copper pipes are built into sections on the plate. This achieves excellent contact, thus ensuring good thermal transmission between the plate and the copper pipe. Standard finish of white (RAL9010) paint.

Note: For more information refer to catalogue and/or Technical Department.

General dimensions

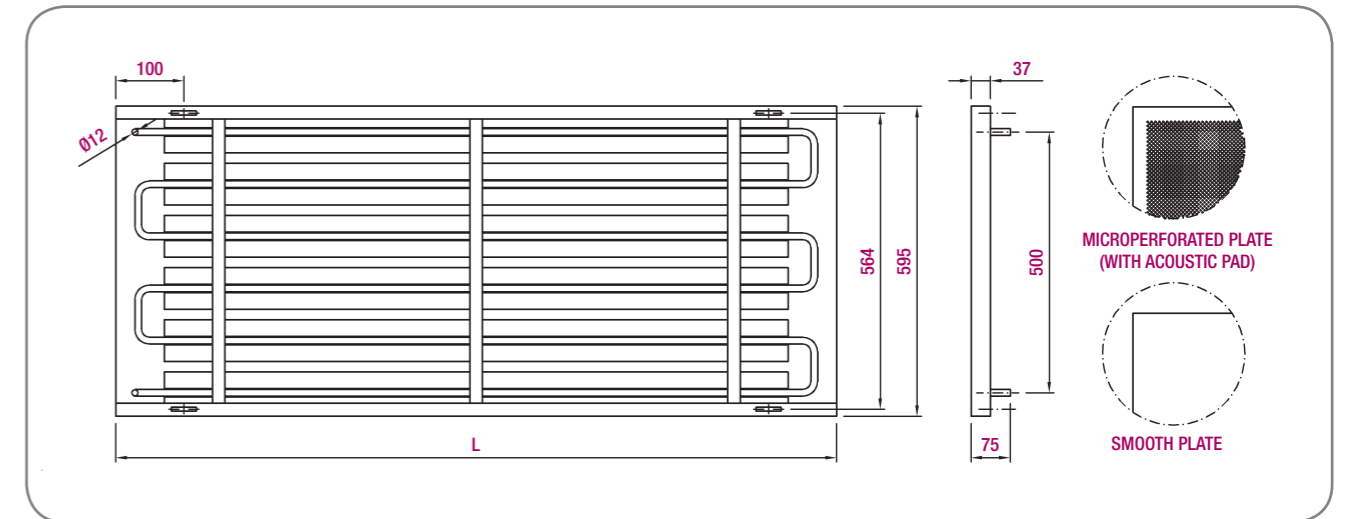

Model	L
1200	1195
1800	1795
2400	2395
3000	2995

Unit mm





Displacement units



**Gas Natural Building
(Madrid – Spain)**

Regulators KCR
and active chilled beam VFK.

S90



Catalogue Series 90



S90-C



Displacement units

Product description

The **S-90** diffusers are displacement units for floor installation. The unit includes upper and lower covers and a perforated air distribution face plate. Connections can be made through the upper or lower cover.

The units are of galvanised steel sheet construction with aluminium sections and include an air equalising plate (painted in black) inside, as well as static pressure measurement to obtain the supply flow rate. The standard finish is RAL 9010 white paint, although any RAL colour is available upon request. The **S-90** displacement diffusers can be used in both comfort and industrial environments. Air is supplied from the occupied area level at a slow outlet velocity (< 0.8 m/s) to minimise turbulence. Depending on the size, the units can also supply large air volumes. Air is supplied at a temperature difference of -1 to -6°C with respect to the ambient temperature. See **S-90** catalog for technical data.

Other models

S-90-C. Round. Dimensions between \varnothing 125 to 630 mm.

S-90-SC. Semicircular. Dimensions between \varnothing 160 to 630 mm.

S-90-CC. Quadrant. Dimensions between \varnothing 160 to 630 mm.

S-90-R. Rectangular. Standard dimensions LxH; L: 600-1200 mm and H: 800-2000 mm.

S-90-R-3. 3-Way Rectangular. Standard dimensions LxH; L: 600-1200 mm and H: 800-2000 mm.

S-90-RT. Horizontal Rectangular. Standard dimensions LxH; L: 800-2000 mm and H: 200-800 mm.

S-90-R-E. Flush-mounted Rectangular. Standard dimensions LxH; L: 400-900 mm and H: 400-600 mm.

General dimensions

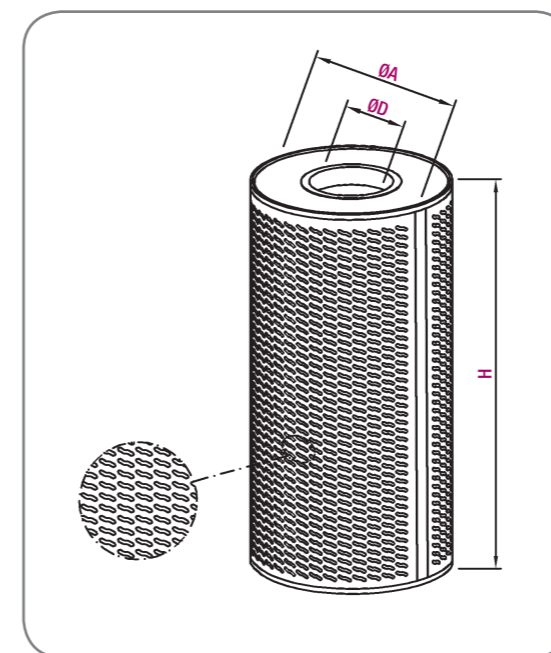

Size	A	C	H	D
160	335	325	900	160
200	375	365	900	200
250	430	420	1200	250
315	495	480	1500	315
400	580	565	1800	400
500	680	665	2000	500
630	810	795	2000	630

Unit mm

Selection table

Model	Q (m³/h)	L _{wa} [dB(A)]	ΔP _t (Pa)	X (m)
125	225	25	15	2.7
	270	30	21	3.5
	310	35	30	4.0
160	320	25	13	2.5
	380	30	17	3.0
	460	35	25	3.6
200	460	25	10	3.0
	550	30	14	4.0
	650	35	20	4.7
250	650	25	9	3.7
	770	30	12	4.6
	930	35	17	5.5
315	1,000	25	7	2.8
	1,100	30	10	3.1
	1,350	35	14	4.8
400	1,400	25	6	3.3
	1,650	30	8	3.8
	1,950	35	12	4.5
500	1,950	25	5	4.1
	2,300	30	7	5.9
	2,800	35	10	6.0
630	2,800	25	4	5.5
	3,400	30	6	6.9
	4,000	35	8	8.0



LEGEND

Q (m³/h): Air flow.
 L_{wa} [dB(A)]: Power noise level.
 ΔP_t (Pa): Pressure loss.
 X (m): Horizontal throw of the air jet, when the velocity in the occupied area is 0.20 m/s for a temperature difference of ΔT = -3 °C.

S90

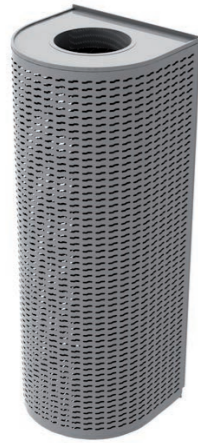

S90-SC

Size	A	H	Ø D
160	335	900	160
200	375	900	200
250	430	1200	250
315	495	1500	315
400	580	1800	400
500	680	2000	500
630	810	2000	630

Unit mm

General dimensions

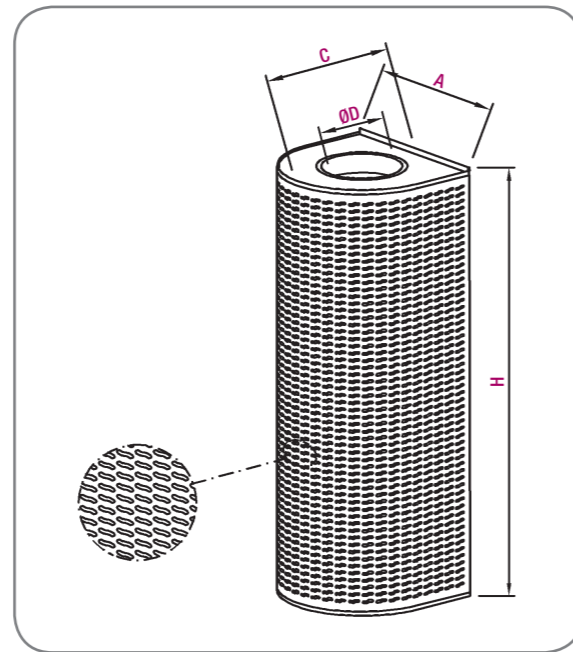

S90-CC

Size	A	H	Ø D
125	250	900	125
160	335	900	160
200	375	900	200
250	430	1200	250
315	495	1500	315
400	580	1800	400
500	680	2000	500
630	810	2000	630

Unit mm

General dimensions

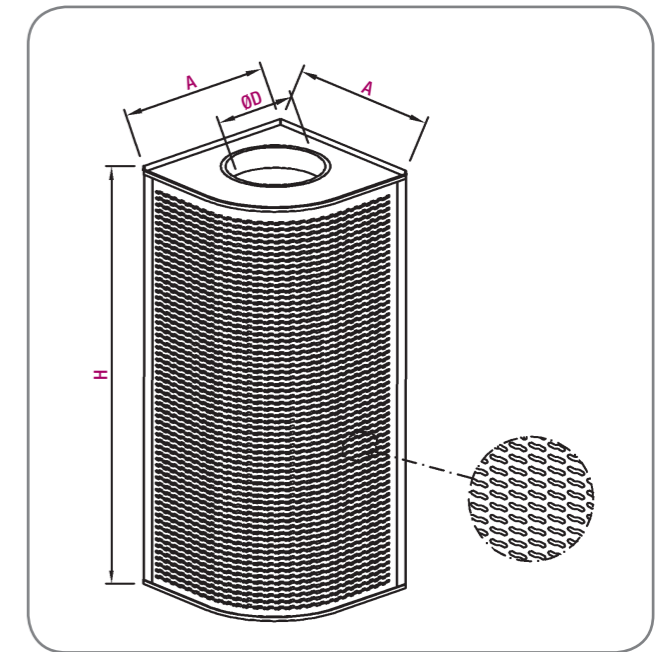

Selection table

Model	Q (m³/h)	L _{WA} [dB(A)]	ΔP _t (Pa)	X (m)
160	320	25	12	5.4
	380	30	17	6.3
	450	35	23	7.5
200	460	25	10	7.1
	550	30	14	8.0
	650	35	20	9.5
250	660	25	9	6.4
	800	30	13	7.1
	950	35	18	7.0
315	980	25	8	3.7
	1,150	30	10	4.1
	1,350	35	14	4.7
400	1,450	25	6	4.4
	1,700	30	9	5.5
	2,000	35	12	5.9
500	2,100	25	5	6.1
	2,450	30	8	7.2
	2,900	35	11	8.0
630	3,100	25	5	7.5
	3,600	30	7	8.0
	4,350	35	10	9.5



LEGEND

Q (m³/h): Air flow.
 L_{WA} [dB(A)]: Power noise level.
 ΔP_t (Pa): Pressure loss.
 X (m): Horizontal throw of the air jet, when the velocity in the occupied area is 0.20 m/s for a temperature difference of ΔT = -3 °C.

Selection table

Model	Q (m³/h)	L _{WA} [dB(A)]	ΔP _t (Pa)	X (m)
160	320	25	12	5.4
	390	30	18	6.3
	460	35	25	7.5
200	450	25	10	7.1
	540	30	14	8.0
	630	35	20	9.5
250	620	25	8	6.4
	740	30	11	7.1
	880	35	13	7.0
315	860	25	6	3.7
	1,040	30	9	4.1
	1,230	35	13	4.7
400	1,250	25	5	4.4
	1,450	30	7	5.5
	1,770	35	10	5.9
500	1,700	25	4	6.1
	2,000	30	6	7.2
	2,400	35	8	8.0
630	2,400	25	4	7.5
	2,850	30	5	8.0
	3,400	35	7	9.5

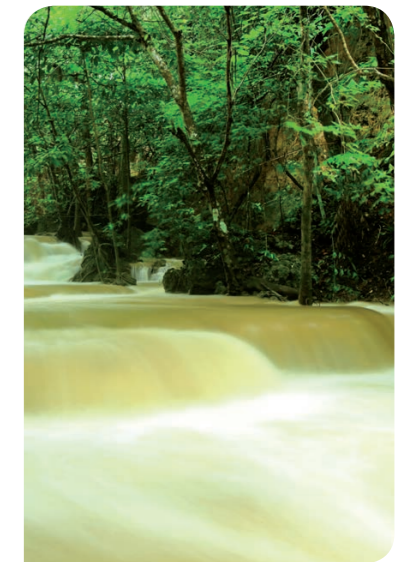

LEGEND

Q (m³/h): Air flow.
 L_{WA} [dB(A)]: Power noise level.
 ΔP_t (Pa): Pressure loss.
 X (m): Horizontal throw of the air jet, when the velocity in the occupied area is 0.20 m/s for a temperature difference of ΔT = -3 °C.

S90



S90-R

General dimensions

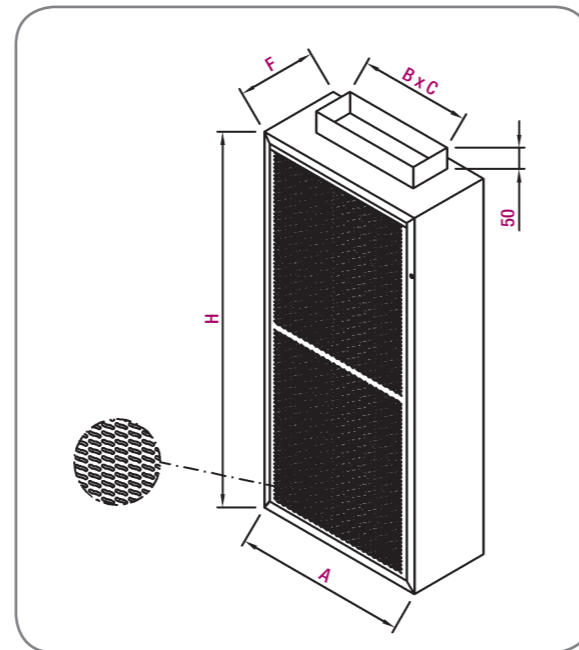

Size	A	H	B	C	F
600 x 800 - 25	600	800	250	150	250
600 x 1200 - 30	600	1200	270	200	300
600 x 1500 - 30	600	1500	400	200	300
1000 x 1500 - 30	1000	1500	650	200	300
1200 x 2000 - 30	1200	2000	900	200	300

Unit mm

Selection table

Model	Q (m³/h)	L _{WA} [dB(A)]	ΔP _t (Pa)	X (m)
600 x 800-25	570	25	12	5.5
	680	30	17	6.7
	820	35	24	7.8
600 x 1200-30	750	25	10	4.5
	920	30	14	5.3
	1,100	35	21	6.4
600 x 1500-30	1,050	25	9	4.7
	1,270	30	13	6.3
	1,500	35	18	8.0
1000 x 1500-30	1,500	25	7	5.0
	1,800	30	10	5.5
	2,170	35	15	7.0
1200 x 2000-30	1,950	25	6	7.3
	2,330	30	8	8.5
	2,800	35	12	10.1



LEGEND

Q (m³/h): Air flow.
 L_{WA} [dB(A)]: Power noise level.
 ΔP_t (Pa): Pressure loss.
 X (m): Horizontal throw of the air jet, when the velocity in the occupied area is 0.20 m/s for a temperature difference of ΔT = -3 °C.

General dimensions



S90-R3

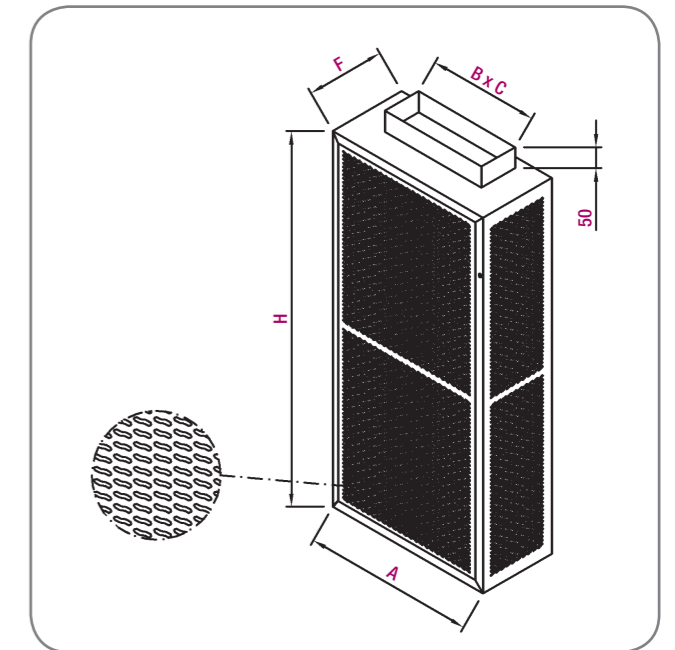

Size	A	H	F	B	C
600 x 800 x 25	600	800	250	250	150
600 x 1200 x 30	600	1200	300	270	200
600 x 1500 x 30	600	1500	300	400	200
1000 x 1500 x 30	1000	1500	300	650	200
1200 x 2000 x 30	1200	2000	300	900	200
1200 x 2000 x 35	1200	2000	350	900	250

Unit mm

Selection table

Model	Q (m³/h)	L _{WA} [dB(A)]	ΔP _t (Pa)	X (m)
600 x 800-25	560	25	11	3.1
	650	30	14	3.3
	780	35	21	4.0
600 x 1200-30	750	25	9	2.7
	870	30	12	3.3
	1,020	35	17	3.8
600 x 1500-30	1,000	25	7	2.2
	1,200	30	11	2.7
	1,400	35	15	3.3
1000 x 1500-30	1,450	25	6	2.3
	1,750	30	9	2.7
	2,050	35	15	3.3
1200 x 2000-30	1,900	25	5	1.8
	2,250	30	7	2.2
	2,650	35	10	2.6
1200 x 2000-35	2,250	25	5	2.3
	2,650	30	8	2.6
	3,200	35	10	3.5



LEGEND

Q (m³/h): Air flow.
 L_{WA} [dB(A)]: Power noise level.
 ΔP_t (Pa): Pressure loss.
 X (m): Horizontal throw of the air jet, when the velocity in the occupied area is 0.20 m/s for a temperature difference of ΔT = -3 °C.

S90



S90-RT

General dimensions

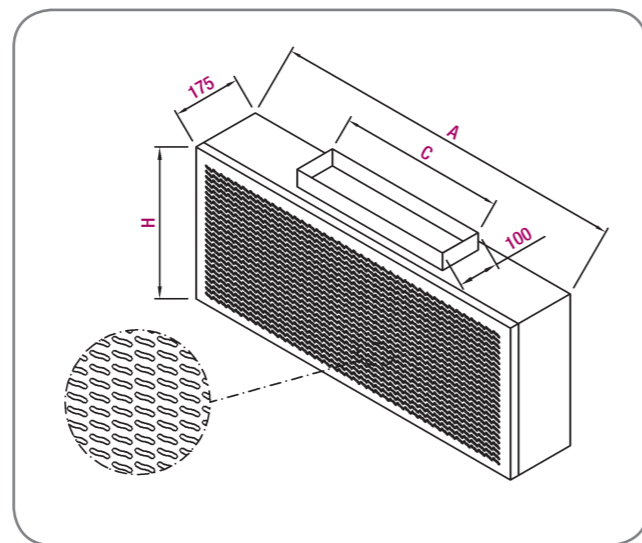

Size	A	H	C
1250 x 200	1250	200	350
1250 x 350	1250	350	400
1450 x 500	1450	500	500
1450 x 650	1450	650	700

Unit mm

Selection table

Model	Q (m³/h)	L _{WA} [dB(A)]	ΔP _t (Pa)	X (m)
1250 x 200	355	25	6	4.0
	430	30	10	4.7
	515	35	14	5.7
1250 x 350	455	25	7	2.9
	545	30	10	3.5
	660	35	14	4.2
1450 x 500	540	25	6	2.0
	650	30	8	2.5
	785	35	12	3.0
1450 x 650	705	25	5	2.0
	850	30	7	2.5
	1,025	35	11	3.0

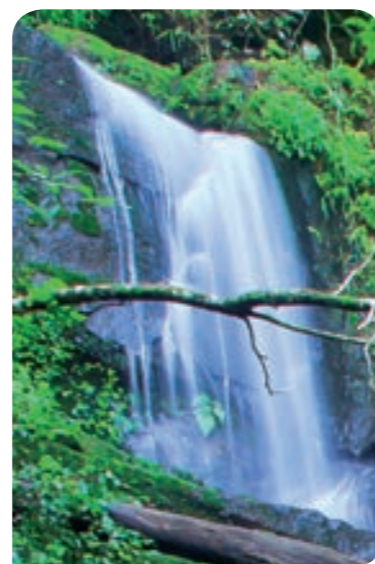

LEGEND

Q (m³/h): Air flow.
 L_{WA} [dB(A)]: Power noise level.
 ΔP_t (Pa): Pressure loss.
 X (m): Horizontal throw of the air jet, when the velocity in the occupied area is 0.20 m/s for a temperature difference of ΔT = -3 °C.

General dimensions



S90-RE

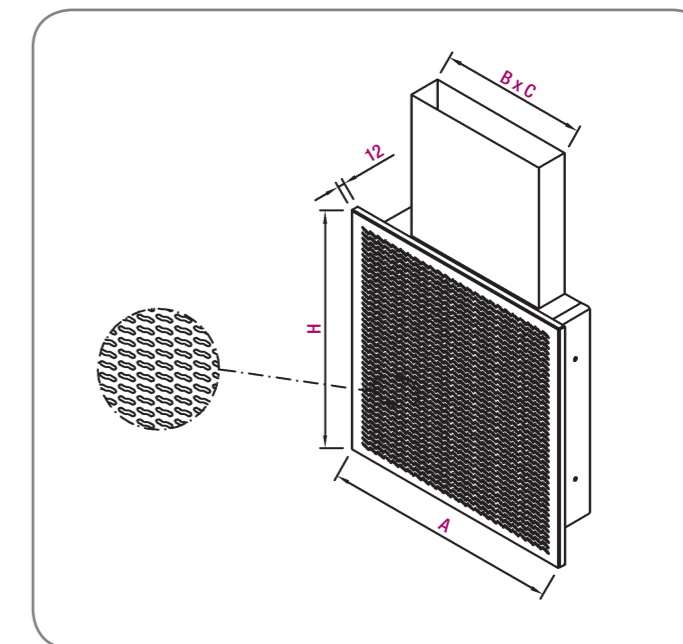

Size	A	H	B	C
400 x 400	402	402	250	50
500 x 500	502	502	350	50
600 x 600	602	602	450	50
900 x 600	902	602	600	60

Unit mm

Selection table

Model	Q (m³/h)	L _{WA} [dB(A)]	ΔP _t (Pa)	X (m)
400 x 400	100	25	3	3.1
	120	30	5	3.7
	145	35	7	4.5
500 x 500	140	25	3	2.8
	170	30	4	3.3
	200	35	6	4.0
600 x 600	175	25	3	2.5
	215	30	4	3.0
	255	35	6	3.6
900 x 600	280	25	3	2.6
	335	30	4	3.1
	400	35	6	3.7



LEGEND

Q (m³/h): Air flow.
 L_{WA} [dB(A)]: Power noise level.
 ΔP_t (Pa): Pressure loss.
 X (m): Horizontal throw of the air jet, when the velocity in the occupied area is 0.20 m/s for a temperature difference of ΔT = -3 °C.

LADES



Catalogue Series 90



Long-Throw Displacement Unit

Product description

The **LADES** diffuser was designed to be installed in rooms with high ceilings (not higher than 5 or 6 m) such as industrial facilities, large stores, etc. The diffuser is octagonal, and the upper section of the terminal is fitted with multiple nozzles for hot air supply.

The lower section has a perforated detachable front housing for cold air supply. For even distribution of air, the interior is equipped with an equalising plate. The multiple nozzle section and the perforated section are separated by a volume control damper controlled by an electric motor, a manual control or a thermal component. The **LADES** diffuser is manufactured of galvanised steel sheet. The multiple nozzles are manufactured of class V0 ABS material, in accordance with UL 94. The entire terminal is painted in RWMZ-60 grey. By special order, the unit can be painted in other colours.

Models

LADES. Flush nozzle plate diffuser.

LADES-I. Tilted nozzle plate diffuser.



General dimensions

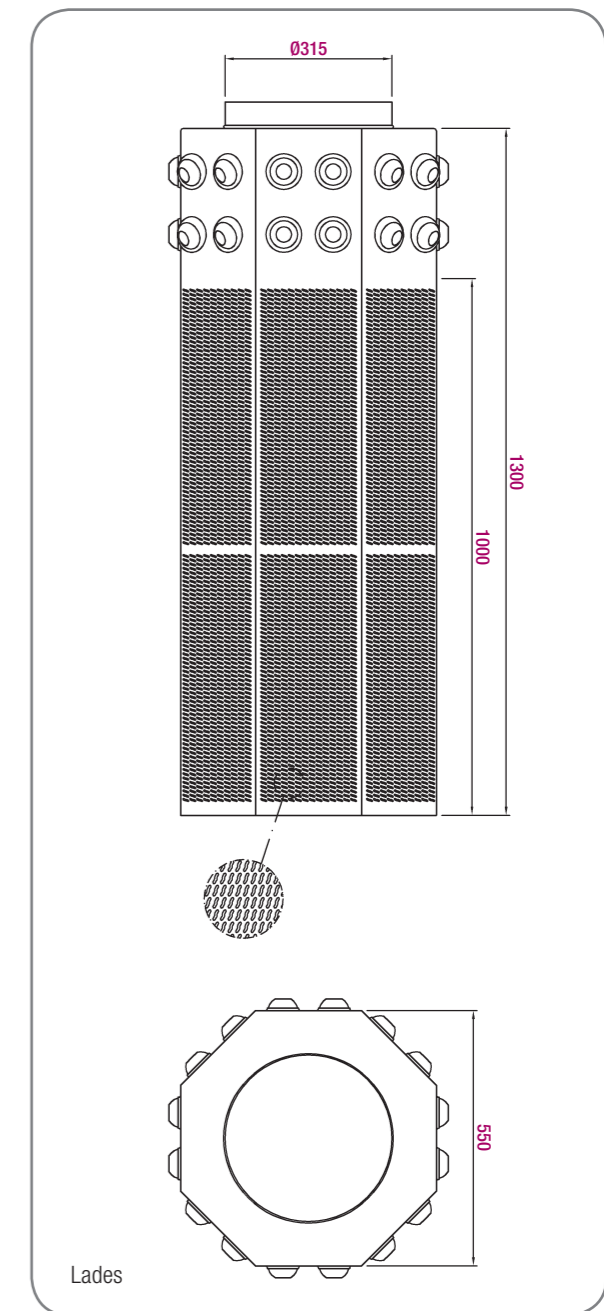
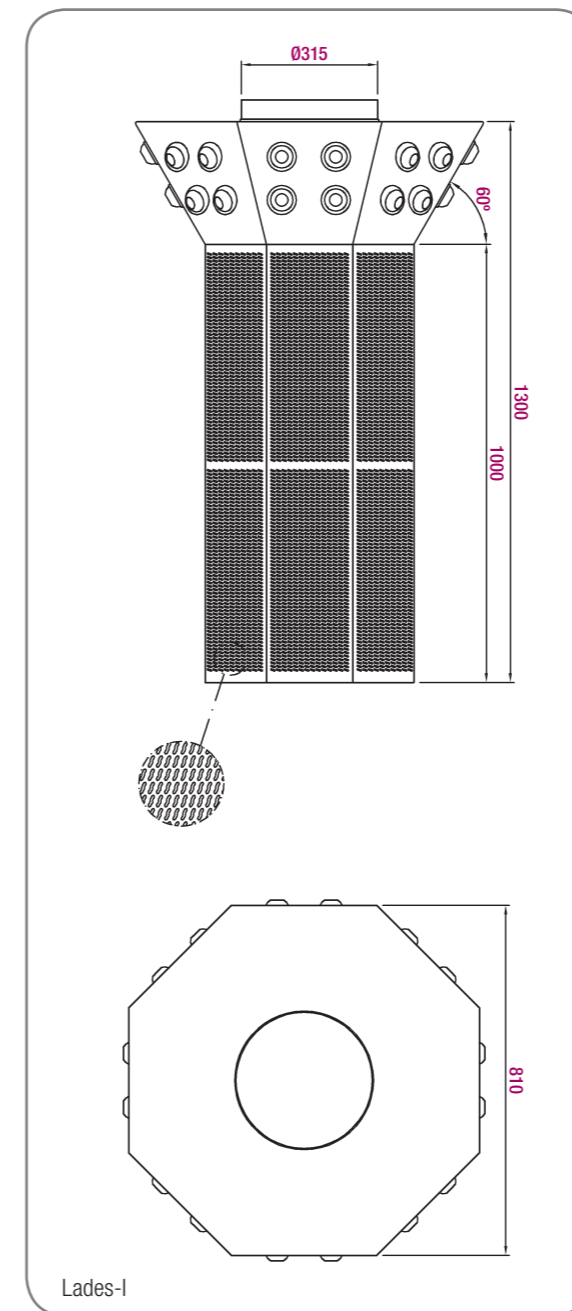

Selection table

Configuration	Q (m³/h)	L _{wa} [dB(A)]	ΔP _t (Pa)	X (m)	V _k (m/s)
Cold	1000	25	11		
	1175	30	15		
	1375	35	21		
Hot	470	25	9	4.1	5.2
	570	30	13	5.0	6.3
	690	35	19	6.1	7.6

LEGEND

Q (m³/h): Air flow.
 L_{wa} [dB(A)]: Puissance acoustique.
 ΔP_t (Pa): Total pressure loss.
 X (m): Maximum velocity of the air stream at 0.50 m from the diffuser.
 V_k (m/s): Effective velocity.

S-90-GV



Catalogue Series S-90-GV



Variable geometry unit

Product description

The **S-90-GV** diffusers are variable geometry units for installation at considerable heights.

They are used in industrial environments, in both heating and cooling systems

They consist of a perforated cylinder, inner discs, and a damper to change the discharge air flow.

The air flows into the cylinder guide through the orifice plate, when contacting the damper changes the discharge air stream.

In cooling mode the air is discharged horizontally and spreads in a radial pattern.

In heating the damper is closed and the air is discharged downwards.

The damper can be adjusted manually, by motor-driven means or by a temperature-adjustable item.

The unit is connected by means of a circular spigot in the upper cover.

The diffusers may be suspended or fixed to columns or walls, on a duct bend or take-off below the main duct.

The recommended minimum installation height is 3 m, until maximum installation heights of 8 m.

Finished

They are made of galvanised steel sheet with built-in equalizing air discs and damper.

The standard finish is RAL 9010 white paint, although any RAL colour is available upon request.

Stainless steel and lateral connection are available as an option.

General dimensions

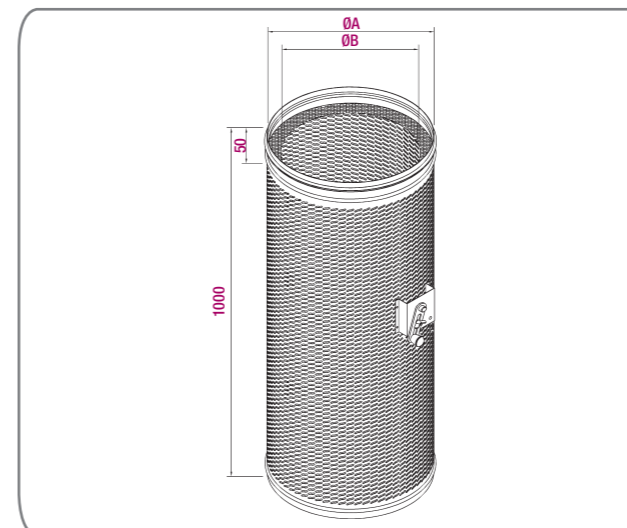

Nominal	Ø A	Ø B
250	248	194
315	313	259
355	353	299
400	398	344
450	449	394
500	498	444
560	558	504
630	628	574

Unit in mm

Selection table (Vertical discharge)

Size	Q (m³/h)	L _{WA} [dB(A)]	ΔP _t (Pa)	Y (m)
250	615	35	16	2,6
	715	40	22	3,1
	835	45	30	3,6
315	915	35	13	3,1
	1070	40	17	3,6
	1250	45	23	4,3
355	1120	35	11	3,4
	1315	40	15	4,0
	1535	45	20	4,6
400	1475	35	10	3,9
	1720	40	14	4,6
	2010	45	19	5,4
450	1805	35	29	4,3
	2010	40	37	4,8
	2460	45	55	5,9
500	2165	35	28	4,6
	2530	40	38	5,4
	2950	45	51	6,3
560	2500	35	23	4,8
	2900	40	31	5,5
	3375	45	42	6,4
630	3030	35	21	5,1
	3540	40	28	6,0
	4135	45	39	7,0

Selection table (Horizontal discharge)

Size	Q (m³/h)	L _{WA} [dB(A)]	ΔP _t (Pa)	X (m)
250	615	35	16	1,2
	750	40	24	1,5
	900	45	35	1,8
315	980	35	14	1,6
	1200	40	22	1,9
	1425	45	30	2,3
355	1250	35	13	1,5
	1500	40	19	1,8
	1800	45	27	2,2
400	1650	35	13	1,8
	2000	40	19	2,2
	2400	45	28	2,6
450	2050	35	38	2,0
	2400	40	52	2,3
	2875	45	75	2,8
500	2400	35	38	2,1
	2900	40	49	2,6
	3500	45	71	3,1
560	3000	35	33	2,3
	3500	40	45	2,7
	4250	45	66	3,3
630	3250	35	24	2,2
	3950	40	35	2,7
	4700	45	50	3,2

LEGEND

Q (m³/h): Air flow.

L_{WA} [dB(A)]: Puissance acoustique.

ΔP_t (Pa): Total pressure loss.

Y (m): Maximum penetration of the air stream of with ΔT = +10° C

Throw for a maximum velocity of 0,20 m/s at the occupied zone, with ΔT = -6° C.

Hospitals Clean rooms

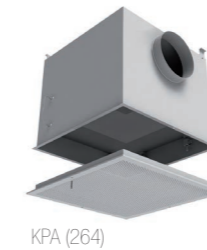

KPA (264)

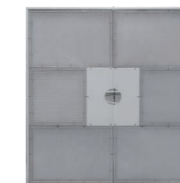

KTF (268)

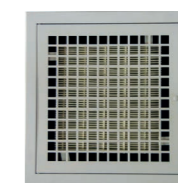

KRH (272)

Móstoles Hospital (Madrid - Spain)

Grilles 20-SHO, 20-45-H and 22-5,
linear floor grille 31-1-F,
square diffuser 50-FR-1,
long throw multinozzle MT3.SB,
swirl diffusers, DFRO, DFRA-OV, DFRO-C and KFD,
extract valves 46-SV,
boxes KS and KSV,
regulators KCR, RCQK and KD-RCQK,
air volume control dampers AOBD-102-E,
absolute filter plenum KPA,
silencers PAM,
active chilled beam VFK-Q 600
and rectangular fire dampers SFR3K1GT + motor and
SFR4 + motor.

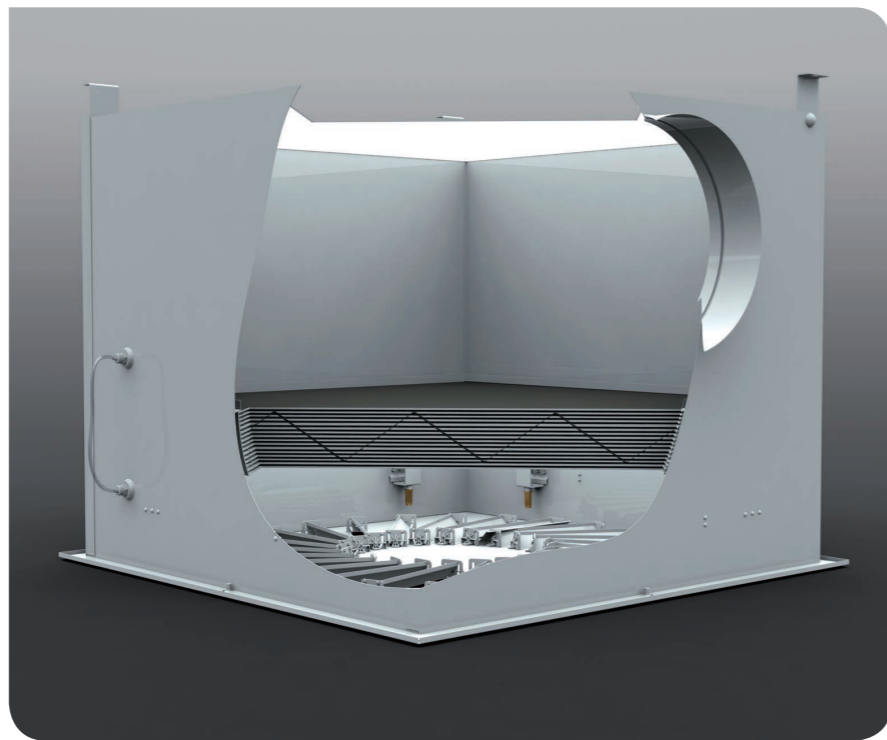
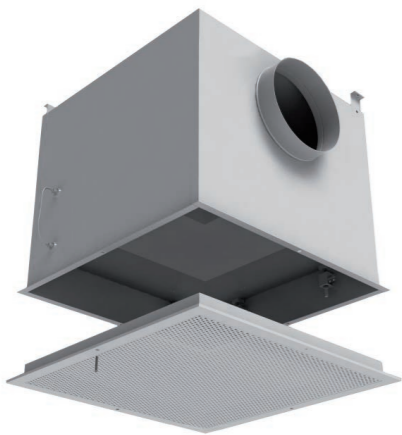

High performance filter plenum

Product description

Plenum and diffusion element set for high-performance filtering. Are available in different sizes and allowing executions including different types of diffuser (swirl, square, perforated plate, ...) Ceiling and wall installation. Plenum manufactured in galvanised steel plate painted on the inside and outside in gloss RAL 9010 or RAL to be defined. Incorporates a pressure connection to measure filter clogging.

Other models

- KPA - BSC.** Circular top entry plenum.
- KPA - BLC.** Circular side entry plenum.
- KPA - BLR.** Rectangular side entry plenum.

Accessories

RE. With pressure device.
KOOLED. Filter clogging control device with KOOLED indicator. Indicates the level of fouling of the filter by measuring the pressure difference across the filter unit (H13, H14, U15, U16). Standard downstream filter clogging pressure of 600 Pa; other downstream pressures configurable on request.

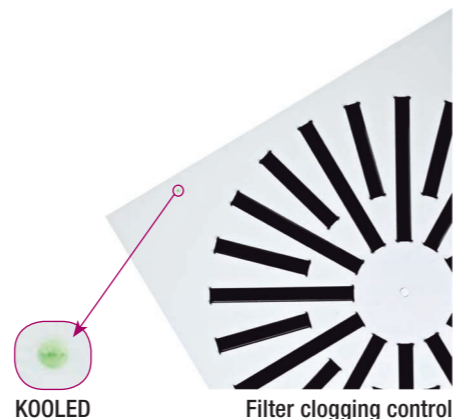

General dimensions

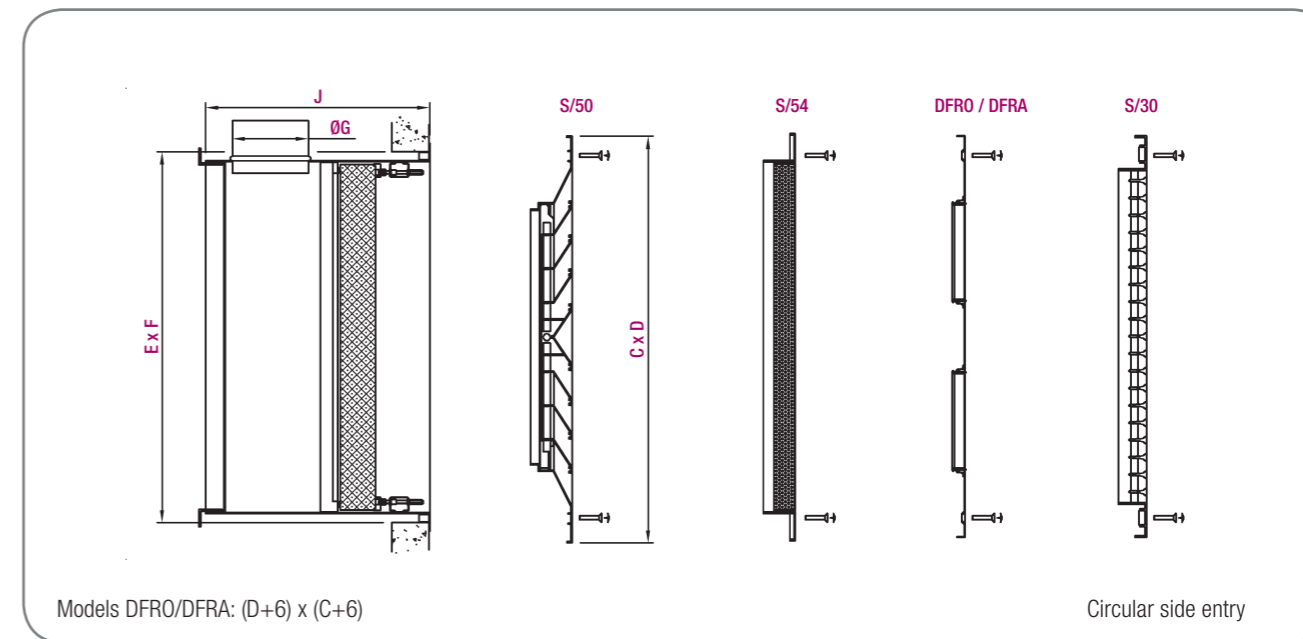

Custom plenums available to suit reduced heights above false ceilings and air flow per unit. Consult Technical Dept.

Filter	C	D	E	F	Ø G	J
305 x 305 x 68	369	369	355	355	123	405
305 x 305 x 90	369	369	355	355	123	427
345 x 345 x 68	409	409	395	395	123	405
345 x 345 x 90	409	409	395	395	158	462
305 x 610 x 68	369	669	355	655	158	440
305 x 915 x 68	369	969	355	959	198	480
457 x 457 x 68	519	519	505	505	158	440
457 x 457 x 90	519	519	505	505	198	502
545 x 545 x 68	594	594	584	584	198	480
545 x 545 x 90	594	594	584	584	248	552
610 x 610 x 68	669	669	655	655	198	480
610 x 610 x 90	669	669	655	655	248	552
610 x 915 x 68	669	969	655	959	248	530
610 x 1220 x 68	669	1274	655	1264	313	595
762 x 762 x 68	827	827	810	810	248	530
762 x 762 x 90	827	827	810	810	313	617
915 x 915 x 68	969	969	955	955	313	596
915 x 915 x 90	969	969	955	955	313	617

Unit mm

Other sizes of filters available

KTF



Catalogue Series KTF

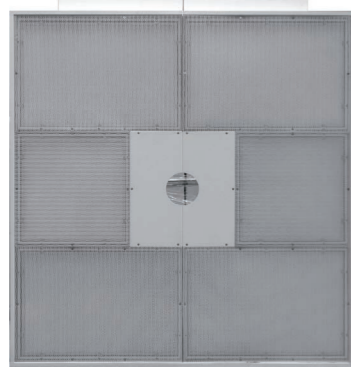

Filtration ceiling

Product description

The filtration ceiling is an air diffusion element for high efficiency filtering of unidirectional flow to comply with all applicable hospital regulations. The KTF filtration ceiling is suitable for Level 3 and 4 risk areas in accordance with NF S 90-351. It complies with ISO class 5 requirements for ambient air quality inside operating rooms in accordance with EN-ISO-14644-1 and with leakage test requirements in accordance with ISO 14644-3.

Finished

Galvanised sheet steel plenum with white epoxy paint RAL 9010. Available in stainless steel AISI-304. Manufactured in a range of sizes. Equipped with a pressure measuring device. The supply grille is made from perforated sheet steel with a free flow area of 50%. Standard sizes include H13 or H14 high efficiency particulate air filters.

Other models

KTF-DIF. For supplying sterile, particle-free air in a vertical descending laminar flow (unidirectional). Differentiating different supply velocities in order to minimise and combat the negative effects of turbulence caused by surgical lamps. This sterile, particle-free flow of stabilised air protects the patient, medical equipment and the surgical instrument table, or the test or work area in the case of clean rooms. Incorporates high-efficiency particulate air filters H13, H14, U15 or U16.

KTF-SL. Filtration ceiling with no central core to integrate lamp with a higher filtering capacity.

Accessories

KOOLED. Filter clogging control device with KOOLED indicator. Indicates the level of fouling of the filter by measuring the pressure difference across the filter unit (H13, H14, U15, U16). Standard downstream filter clogging pressure of 600 Pa; other downstream pressures configurable on request.

General dimensions KTF

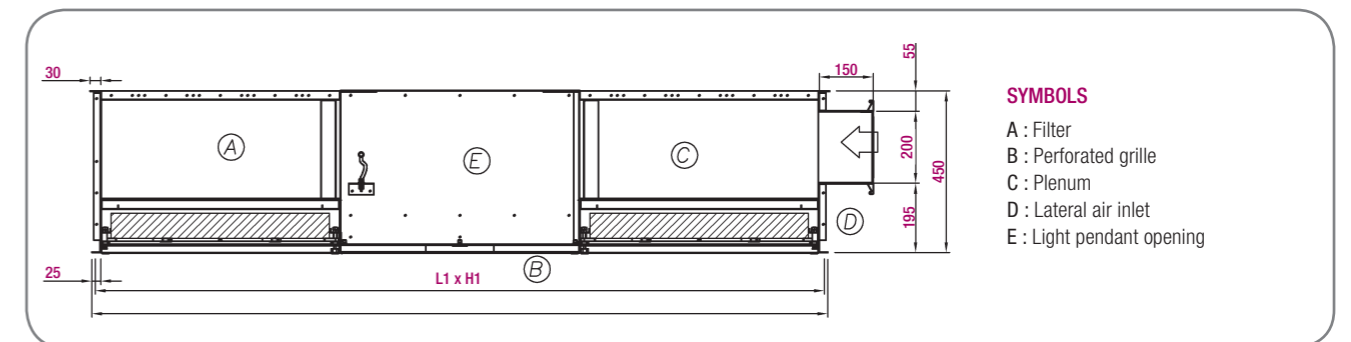
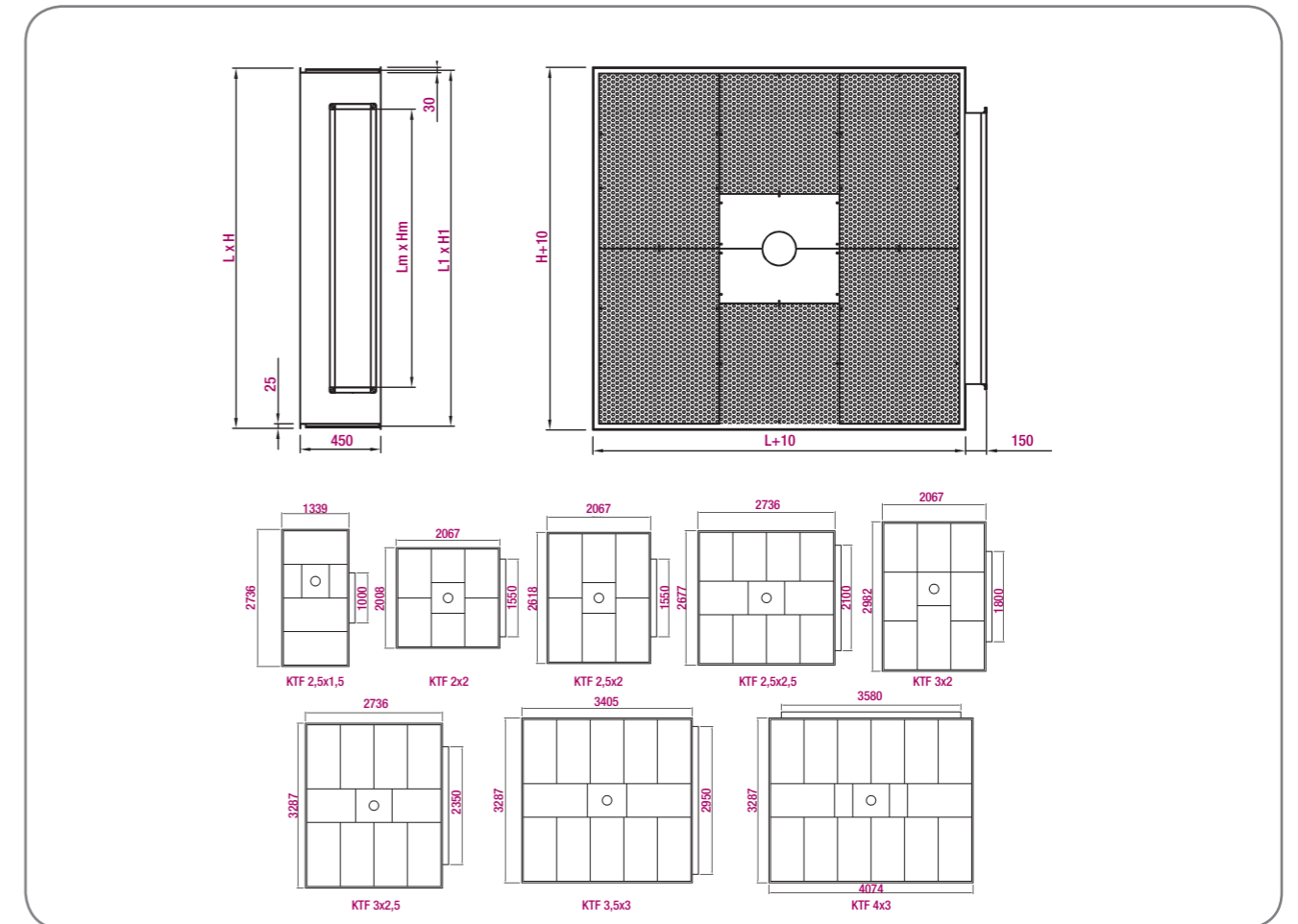

- SYMBOLS**
- A : Filter
 - B : Perforated grille
 - C : Plenum
 - D : Lateral air inlet
 - E : Light pendant opening

Model	Hole L1 H1	Total dimension L x H x A	Spigot Lm x Hm	No. of parts
2,5 x 1,5	1309 2706	1329 x 2726 x 450	1000 x 200	1
2 x 2	2037 1978	2057 x 1998 x 450	1550 x 200	2
2,5 x 2	2037 2588	2057 x 2608 x 450	1550 x 200	2
3 x 2	2037 2952	2057 x 2972 x 450	1800 x 200	2
2,5 x 2,5	2706 2647	2726 x 2667 x 450	2100 x 200	2
3 x 2,5	2706 3257	2726 x 3277 x 450	2350 x 200	4
3,5 x 3	3375 3257	3395 x 3277 x 450	2950 x 200	4
4 x 3	4044 3257	4064 x 3277 x 450	3580 x 200	4

Unit mm

Note: For more information refer to catalogue and/or Technical Department.

General dimensions KTF-SL

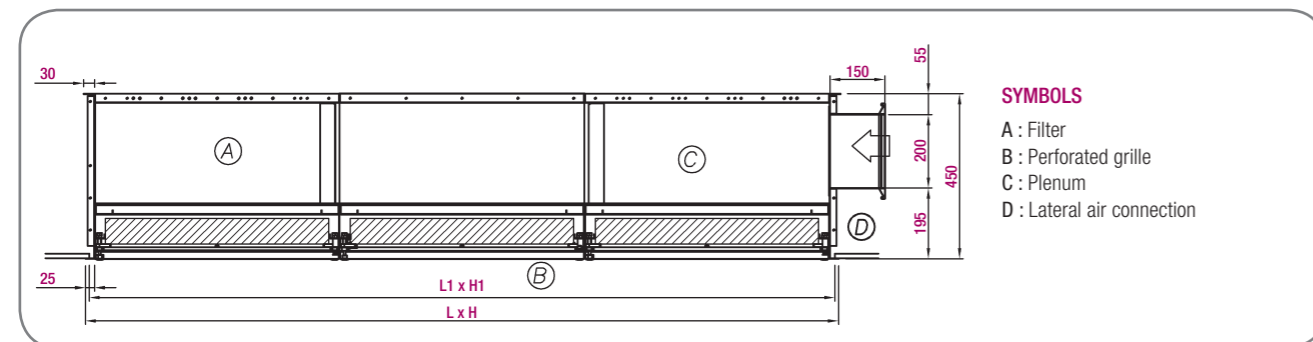
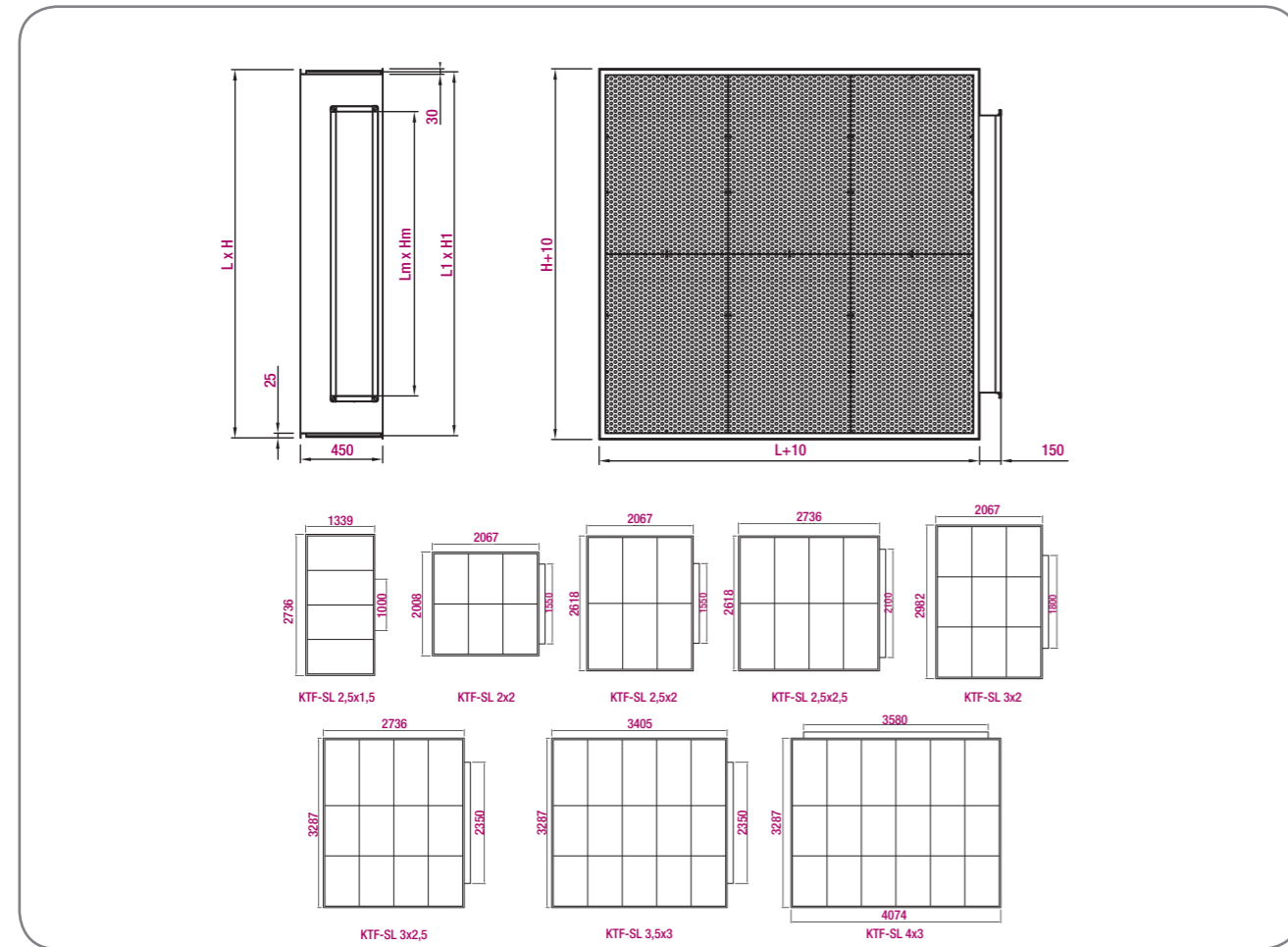

Model	Hole		Total dimension L x H x A	Spigot Lm x Hm	No. of parts
	L1	H1			
2,5 x 1,5	1309	2706	1329 x 2726 x 450	1000 x 200	1
2 x 2	2037	1978	2057 x 1998 x 450	1550 x 200	2
2,5 x 2	2037	2588	2057 x 2608 x 450	1550 x 200	2
3 x 2	2037	2952	2057 x 2972 x 450	1800 x 200	2
2,5 x 2,5	2706	2588	2726 x 2608 x 450	2100 x 200	2
3 x 2,5	2706	3257	2726 x 3277 x 450	2350 x 200	4
3,5 x 3	3375	3257	3395 x 3277 x 450	2950 x 200	4
4 x 3	4044	3257	4064 x 3277 x 450	3580 x 200	4

Unit mm

Selection table using flow rate

SIZE	FILTERS		KTF									
	UNITS	SIZE	Q (m³/h)		ΔP _{filter} (Pa)		ΔP _{diffuser} (Pa)		ΔP _{total} (Pa)		L _{wa} [dB(A)]	
			max	min	max	min	max	min	max	min	max	min
2,5 x 1,5	3	1200x610x68	4350	2190	160	40	1	1	161	41	<20	<20
	2	610x305x68										
2 x 2	4	915x610x68	4800	2200	160	40	1	1	161	41	<20	<20
	2	610x610x68										
2,5 x 2	4	1220x610x68	6800	3420	160	40	1	1	161	41	<20	<20
	2	915x610x68										
3 x 2	1	1220x610x68	7550	3780	160	40	1	1	161	41	<20	<20
	7	915x610x68										
2,5 x 2,5	10	915x610x68	9000	4500	160	40	1	1	161	41	<20	<20
3 x 2,5	8	1220x610x68	11800	5940	160	40	1	1	161	41	<20	<20
	2	915x610x68										
3,5 x 3	12	1220x610x68	15000	7560	160	40	1	1	161	41	<20	<20
4 x 3	14	1220x610x68	18100	9120	160	40	1	1	161	41	<20	<20
	2	610x305x68										

SIZE	FILTERS		KTF-SL									
	UNITS	SIZE	Q (m³/h)		ΔP _{filter} (Pa)		ΔP _{diffuser} (Pa)		ΔP _{total} (Pa)		L _{wa} [dB(A)]	
			max	min	max	min	max	min	max	min	max	min
2,5 x 1,5	4	1200x610x68	5000	2520	160	40	1	1	161	41	<20	<20
2 x 2	6	915x610x68	5400	2700	160	40	1	1	161	41	<20	<20
2,5 x 2	6	1200x610x68	7500	3780	160	40	1	1	161	41	<20	<20
2,5 x 2,5	8	1200x610x68	10000	5041	160	40	1	1	161	41	<20	<20
3 x 2	9	915x610x68	8100	4050	160	40	1	1	161	41	<20	<20
3 x 2,5	4	1220x610x68	12200	6120	160	40	1	1	161	41	<20	<20
	8	915x610x68										
3,5 x 3	5	1220x610x68	15250	7625	160	40	1	1	161	41	<20	<20
	10	915x610x68										
4 x 3	6	1220x610x68	18300	9180	160	40	1	1	161	41	<20	<20
	12	915x610x68										

LEGEND

- Q (m³/h): Air flow.
- L_{wa} [dB(A)]: Power noise level.
- ΔP_{filter} (Pa): Pressure loss in the filter.
- ΔP_{diffuser} (Pa): Pressure loss in the diffuser.
- ΔP_{total} (Pa): Total pressure loss.

Selection table using air velocity through filter

Model	KTF			KTF-SL		
	Air velocity through filter (m/s)			Air velocity through filter (m/s)		
	0,2	0,3	0,4	0,2	0,3	0,4
2,5 x 1,5	1880	2820	3760	2150	3220	4290
2 x 2	2150	3220	4290	2420	3620	4830
2,5 x 2	2950	4430	5900	3220	4830	6430
3 x 2	3350	5030	6700	3620	5430	7240
2,5 x 2,5	4020	6030	8040	4290	6430	8580
3 x 2,5	5100	7640	10190	5360	8040	10720
3,5 x 3	6430	9650	12860	6700	10050	13400
4 x 3	7770	11660	15540	8040	12060	16080

Air flow in m³/h

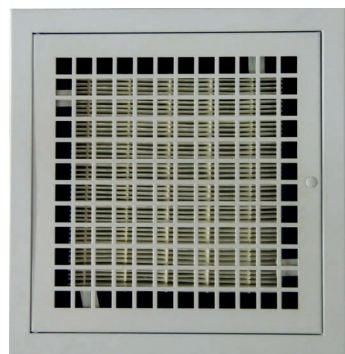

Filterholder return grille

Product description

Filterholder return grille brand Koolair, model **KRH** for installation in clean rooms, pharmaceutical industries and hospital settings. Possibility of G4 to F7 filtration (48 mm) or G4 (13 mm) + F7 (34 mm) double filtration.

They are used for air evacuation in surgical theatres and rooms with high cleanliness requirements. This filter is easy to clean and can be seen from the room, which makes clogging easy to check for fast, simple maintenance. Filters installed flush with the grille to prevent "dead areas" with quick 1/4-turn tab changes. Lateral or top connection plenum manufactured. Differential pressure meter included. Possibility of ceiling mount. Air evacuation from surgical theatres with F5 filtration as recommended in NF S 90-351.

Finished

Standard finish in galvanized steel, epoxy paint, RAL 9010 color. By special order, other RAL colours can be requested. Optional AISI 304 stainless steel.

Accessories

- PFS.** Plenum box with upper discharge.
- PFL.** Lateral discharge plenum.
- PFE.** Pyramidal plenum box with lateral discharge
- 290.** Control damper in discharge.

Models

- KRH.** Filterholder return grille with G4 filtration.
- KRH-2.** Filterholder return grille with G4+F7 double filtration.

Note: For more information refer to catalogue and/or Technical Department.

General dimensions

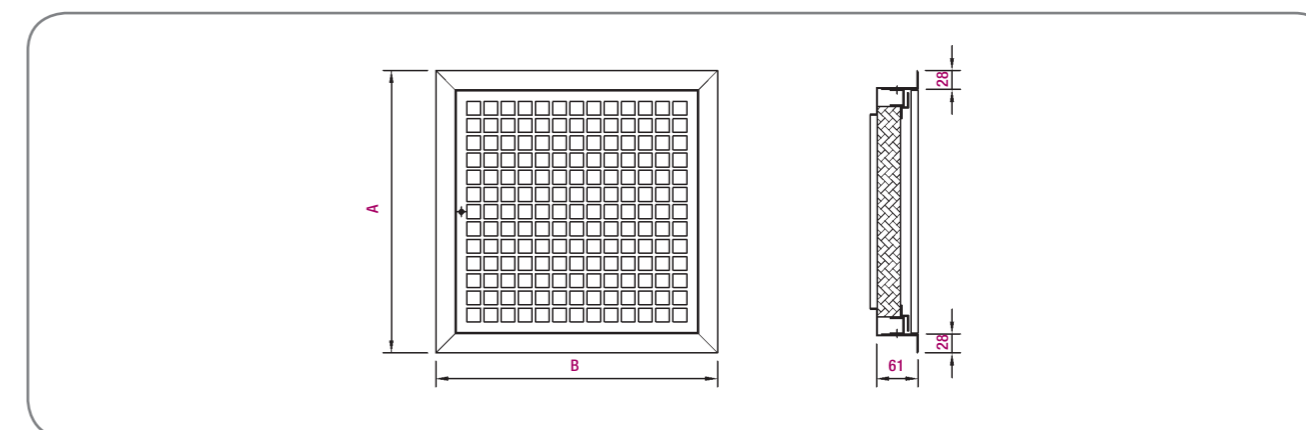

Model	Filter	Grille		Model	Filter	Grille	
		A	B			A	B
KRH 3015 R	305 x 150 x 48	415	260	KRH 6130 R	610 x 305 x 48	720	415
KRH 3915 R	395 x 150 x 48	505	260	KRH 3949 R	395 x 490 x 48	505	600
KRH 3030 R	305 x 305 x 48	415	415	KRH 3961 R	395 x 610 x 48	505	720
KRH 3039 R	305 x 395 x 48	415	505	KRH 4949 R	490 x 490 x 48	600	600
KRH 3049 R	305 x 490 x 48	415	600	KRH 4961 R	490 x 610 x 48	600	720
KRH 4930 R	490 x 305 x 48	600	415	KRH 6161 R	610 x 610 x 48	720	720
KRH 3939 R	395 x 395 x 48	505	505	KRH 4991 R	490 x 915 x 48	600	1025
KRH 3061 R	305 x 610 x 48	415	720	KRH 7676 R	762 x 762 x 48	872	872

Unidad en mm

Selection table (1 grille)

Model	Q (m³/h)
KRH 3015 R	200
KRH 3915 R	320
KRH 3030 R	500
KRH 3039 R	540
KRH 3049 R	800
KRH 4930 R	800
KRH 3939 R	840
KRH 3061 R	970
KRH 6130 R	970
KRH 3949 R	1000
KRH 3961 R	1220
KRH 4949 R	1220
KRH 4961 R	1560
KRH 6161 R	1950
KRH 4991 R	2340
KRH 7676 R	3030

Selection table (2 grilles)

Lower grille	Upper grille	Q (m³/h)
KRH 3030 R	KRH 3015 R	500
KRH 3939 R	KRH 3915 R	850
KRH 3061 R	KRH 3030 R	975
KRH 3961 R	KRH 3939 R	1225
KRH 4961 R	KRH 4930 R	1600
KRH 6161 R	KRH 6130 R	2000
KRH 4991 R	KRH 4949 R	2350

Total reference flow



More...



**Real Madrid Residence
(Madrid – Spain)**

Grille S-20, linear grille S-30,
circular diffusers 43-SF,
swirl diffusers DFRO, DFRA-OV and DFTR-R,
linear diffusers LK-70,
long throw multinozzle DF-49-MT3-SB,
regulators RCCK and RCQK
and rectangular fire dampers SFR.

AOBD-C3

Airtight regulating damper

Product description

KOOLAIR regulating damper with opposed and aerodynamic blades, model AOBD-C3. Meets specifications established in EN 1751 achieving class "C" air tightness through the casing and class "3" air tightness through the blades of the damper by means of a V1 classified self-extinguishing PVC gasket.

The movement of the blades is ensured via gears that achieve the proper level of friction. Manual or motor-driven operation. Blade heights of 75 mm

General dimensions

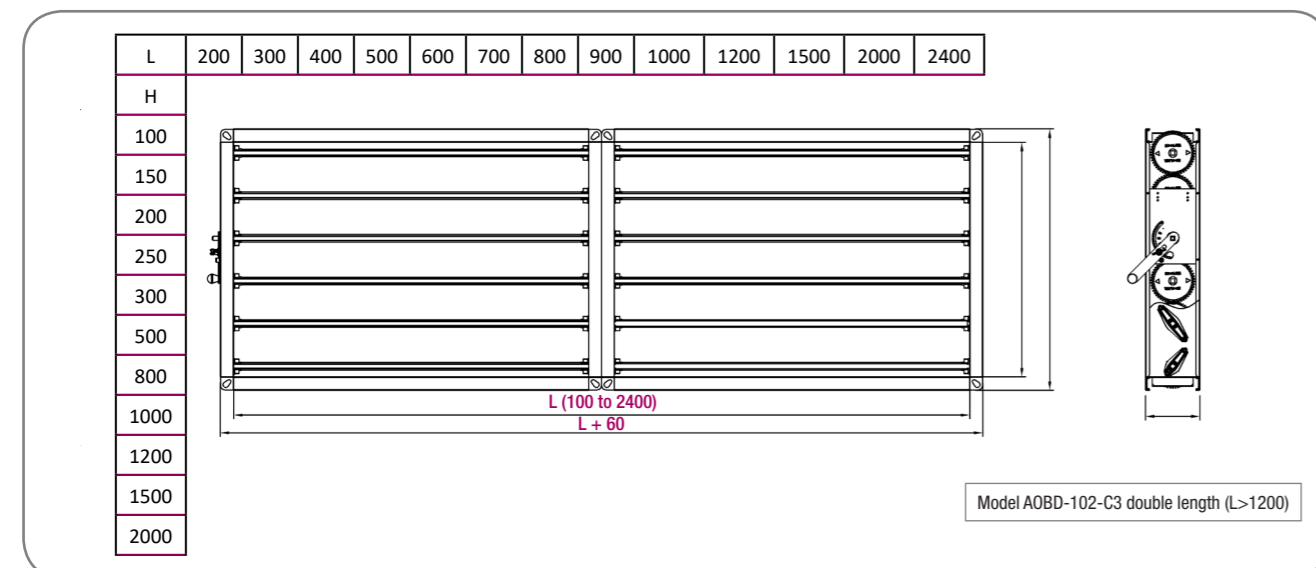

Manufactured in 50mm length and height increments.

Note: For more information refer to catalogue and/or Technical Department.



AOBD



AOBD Manually operated



AOBD Ready to be motorized



Regulating Damper

Product description

Regulating damper with opposed and aerodynamic vanes, manufactured in aluminium (**AOBD**). The body of the damper has built-in air tight gaskets all around its inner perimeter to ensure a tight seal. The movement of the vanes is ensured by means of gears, achieving a proper friction, with manual or

General dimensions

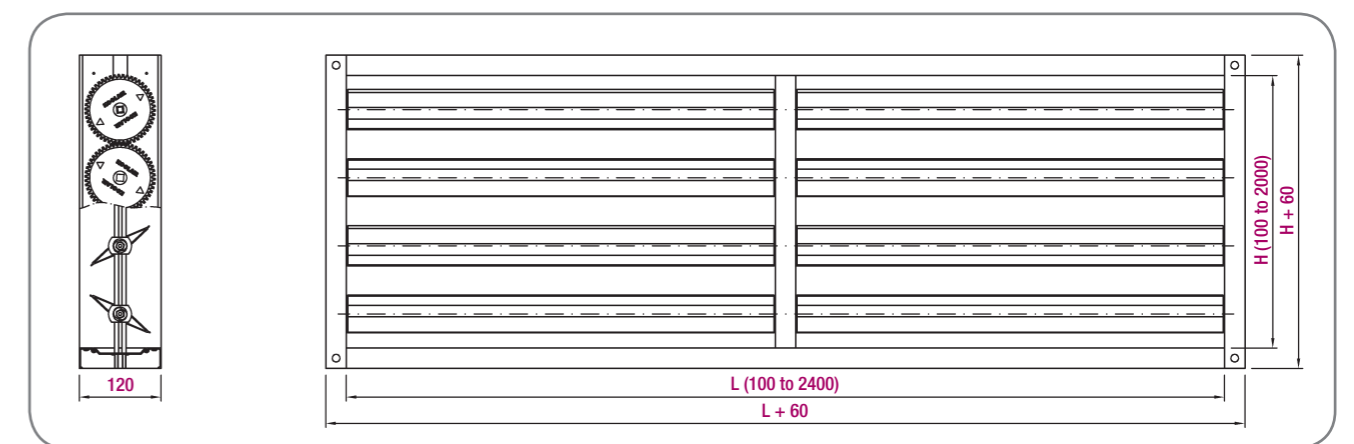

motor-driven operation.

Vaness are available with 50 mm vane axis distances, to complete the entire range of standard duct dimensions. Finishes in natural aluminium.

Note: For more information refer to catalogue and/or Technical Department.

210-TA



Catalogue Series 100-200

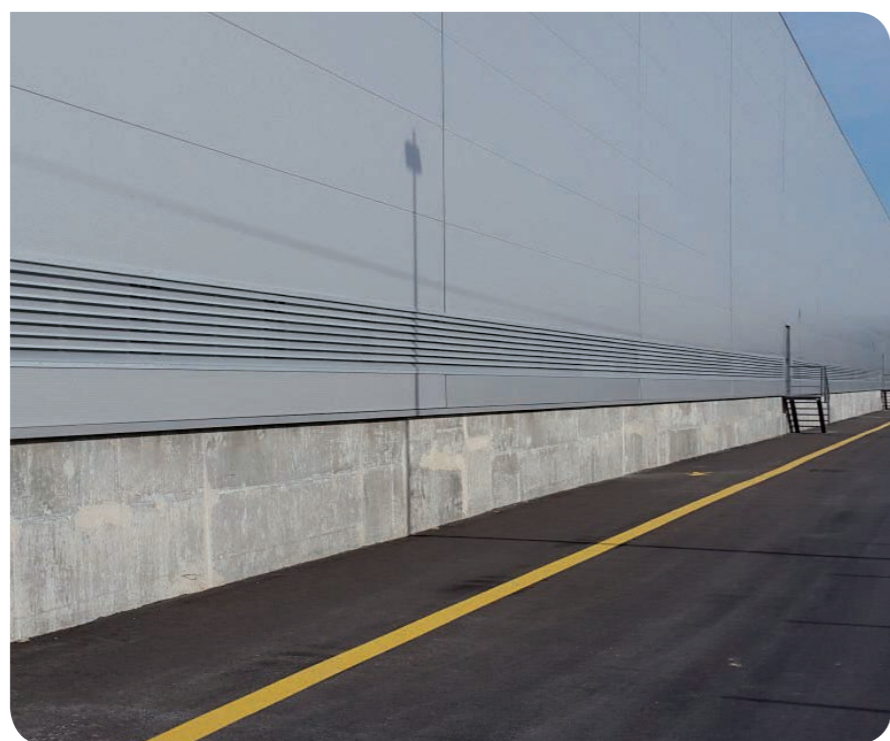

Louvre for outdoor air intake

Product description

Louvres for outdoor air intake, KOOLAIR **210-TA** model, with bird-proof metal mesh. The blade design and shape prevents viewing. In addition, ingress of rainwater, snow, etc., is prevented, as it is mainly designed for outdoor installation. Comes with bird-proof or insect-proof mesh. The neck of the louvre frame is fitted with anchoring

tabs for on-site installation. Manufactured in aluminium. Standard natural aluminium finish. Available in anodized aluminium and other RAL colours, by special order.

Mounting

MM. With mounting frame.
T. With screws.

General dimensions

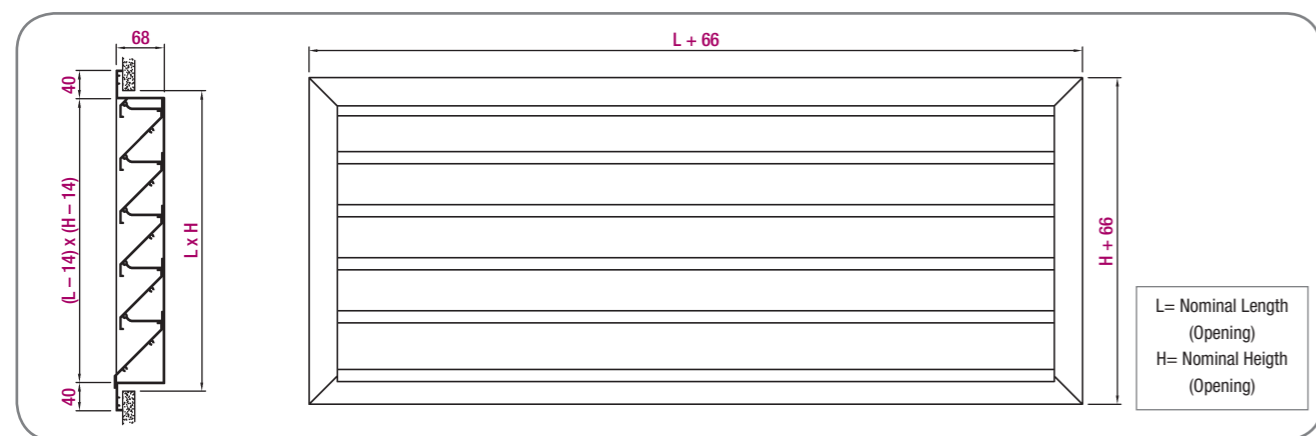

Note: For more information refer to catalogue and/or Technical Department.



Catalogue Series 100-200

TAC-200



Round louvre for outdoor air intake

Product description

Round louvre for outdoor air intake, KOOLAIR **TAC-200** model. The blade design and shape prevents viewing. In addition, the ingress of rainwater, snow, etc., is prevented, as it is mainly designed for outdoor installation.

Its round shape makes it ideal in sites where, for architectural reasons, the installation of conventional rectangular air intakes is ruled out. The louvre frame includes drilled holes for bolted flush mounting. Manufactured in extruded aluminium, painted in white RAL 9010.

General dimensions

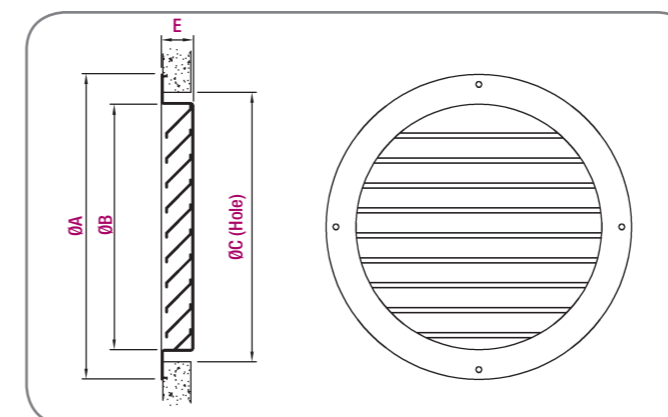

Nominal	Ø A	Ø B	Ø C	E
125	181	121	145	
160	216	156	180	
200	256	196	220	
250	306	246	270	
315	375	295	315	
400	460	380	400	32
450	510	430	450	
500	560	480	500	
630	690	610	630	
710	770	690	710	
800	882	782	800	
1000	1082	982	1000	63,5
1250	1332	1232	1250	

Unit mm

Note: For more information refer to catalogue and/or Technical Department.

230-SP



Catalogue Series 100-200



Overpressure damper

Product description

Overpressure damper, KOOLAIR **230-SP** model. Includes sealing strip in fins for more efficient closure and sound absorption. By special order, they can be supplied with a U-frame, with inverted fins, interconnected fins, etc. The frame includes drilled holes for flush-mounting or duct attachment with bolts or rivets. Manufactured in extruded aluminium, standard natural aluminum finish.

General dimensions

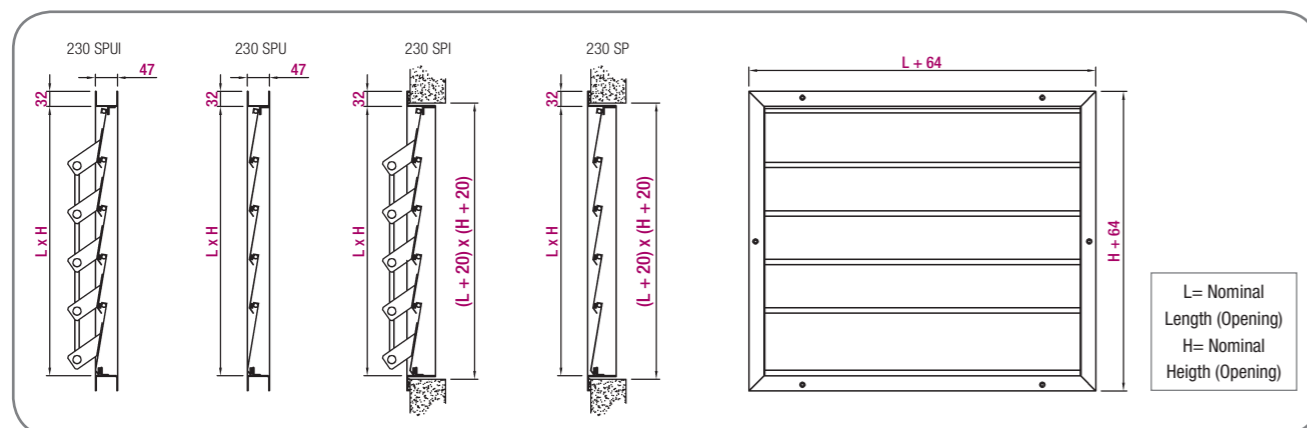

Note: For more information refer to catalogue and/or Technical Department.

CSP-C



Round overpressure damper

Product description

Round overpressure damper, KOOLAIR **CSP-C** model. Standard housing finish in galvanized steel sheet; fin in aluminium.

General dimensions

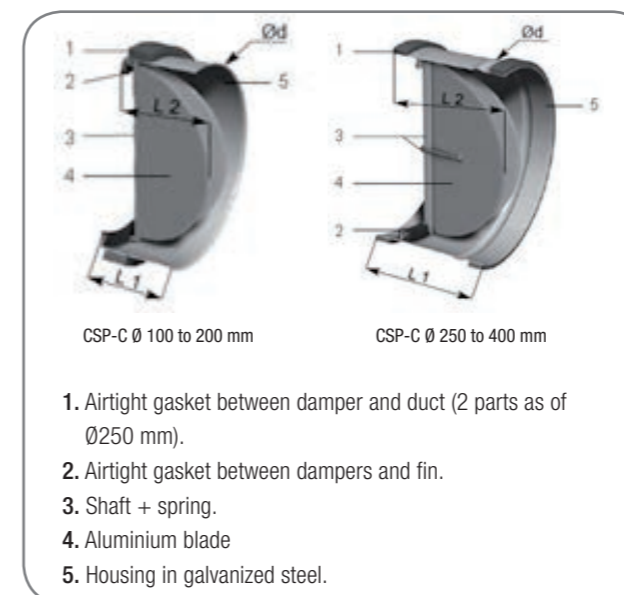

Note: For more information refer to catalogue and/or Technical Department.

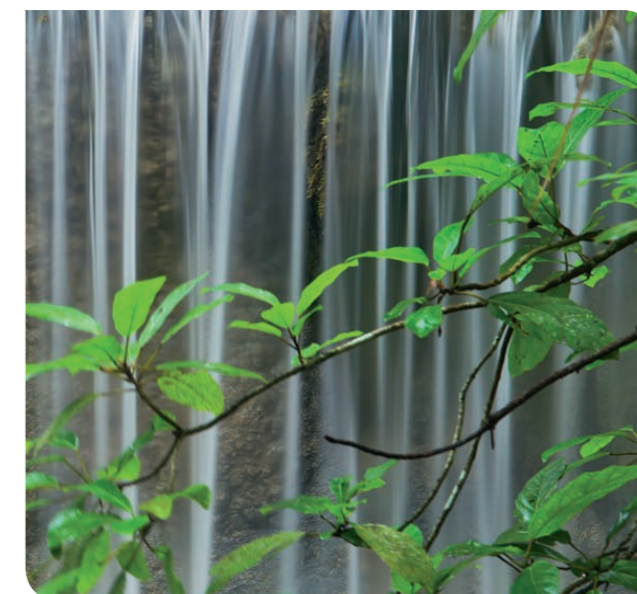

Static pressure loss through the damper table

Model	ΔP_{st} (Pa)	
	V_c (m/s) = 2	V_c (m/s) = 4
CSP-C 100	78	85
CSP-C 125	56	64
CSP-C 150	33	40
CSP-C 160	30	33
CSP-C 200	15	14
CSP-C 250	13	15
CSP-C 315	11	11
CSP-C 355	9	10
CSP-C 400	8	9

ΔP_{st} (Pa): Static pressure loss through the damper.
 V_c (m/s): Flow velocity in the duct or at the damper inlet.

Model	$\varnothing d$ (mm)	L1 (mm)	L2 (mm)
CSP-C 100	96	43	50
CSP-C 125	121	49	63
CSP-C 150	146	62	76
CSP-C 160	155	66	81
CSP-C 200	195	72	93
CSP-C 250	247	120	145
CSP-C 315	312	160	178
CSP-C 355	352	160	198
CSP-C 400	397	160	223

PE-20/21

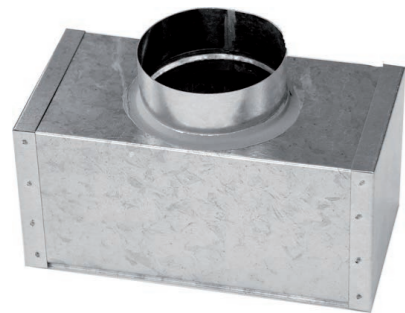

Models

PE-20. Upper connection plenum, removable for attachment by clips to the grille. Standard uninsulated finish and without flap at inlet. Manufactured in galvanized steel sheet.

PE-21. Lateral connection plenum, removable for attachment by clips to the grille. Standard uninsulated finish and without flap at outlet. Manufactured in galvanized steel sheet.

Connection plenum for S-20 and S-30 grilles

Available with insulation (-A) and damper at outlet, upon request.

General dimensions

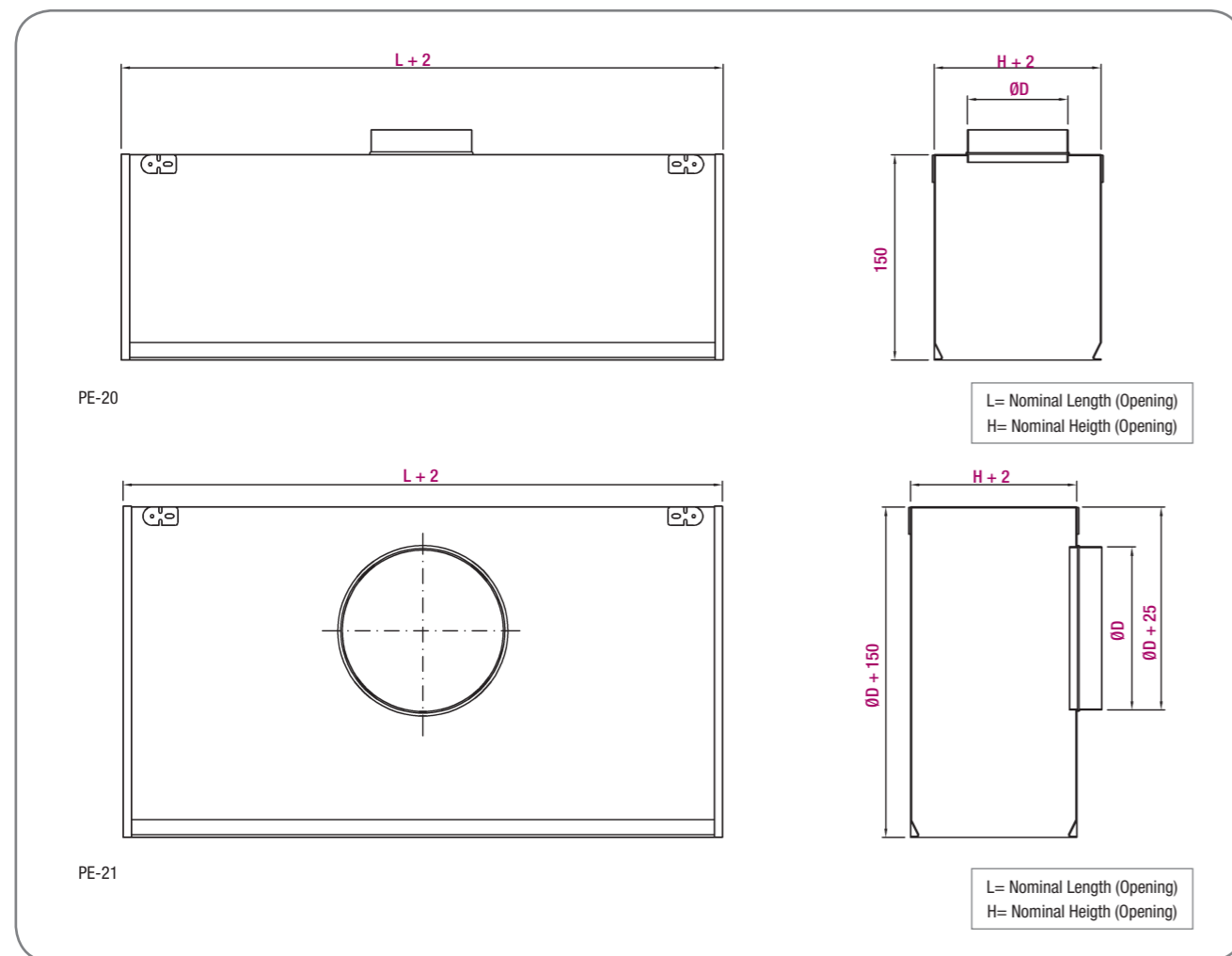

Please consult us for dimension details.

Note: For more information refer to catalogue and/or Technical Department.

PE-40/41

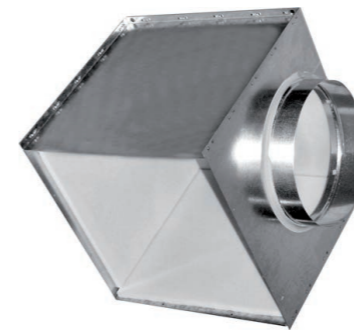

Models

PE-40. Upper connection plenum. Standard uninsulated finish and without flap at outlet. Manufactured in galvanized steel sheet.

PE-41. Lateral connection plenum. Standard uninsulated finish and without flap at outlet. Manufactured in galvanized steel sheet.

Plenum for square diffusers

Available with insulation (-A) and damper at outlet, upon request.

General dimensions

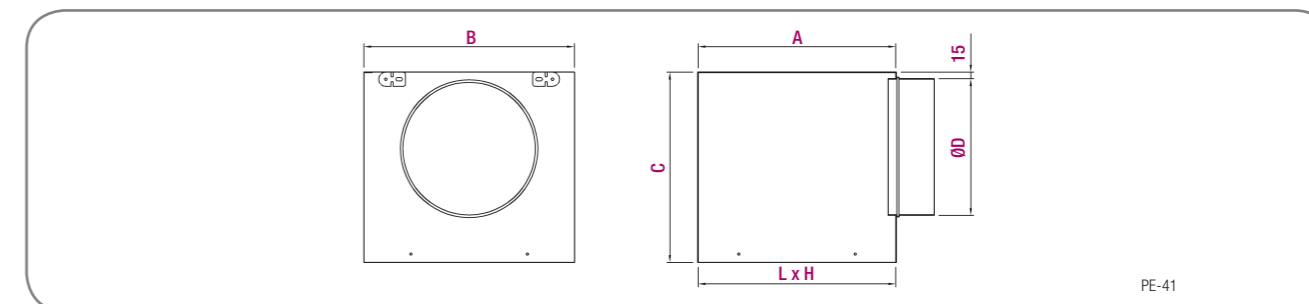

Nominal (L x H)	A	B	C	Ø D
150 x 150	150	180	239	124
225 x 225	225	255	274	159
300 x 300	300	330	314	199
375 x 375	375	405	364	249
450 x 450	450	480	429	314
525 x 525	525	555	469	354
600 x 600	600	630	514	399

Unit in mm

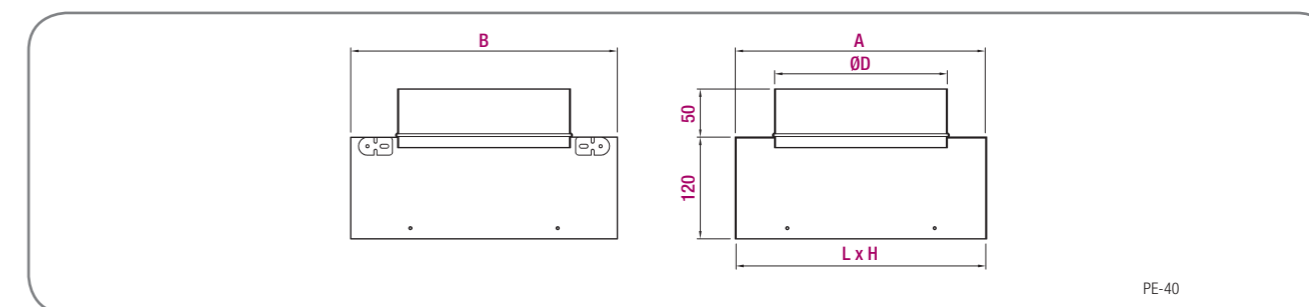

Nominal (L x H)	A	B	Ø D
150 x 150	152	152	124
225 x 225	227	227	159
300 x 300	302	302	199
375 x 375	377	377	249
450 x 450	452	452	314
525 x 525	527	527	354
600 x 600	602	602	399

Unit in mm

Note: For more information refer to catalogue and/or Technical Department.

PE-45



Catalogue Series PE-45

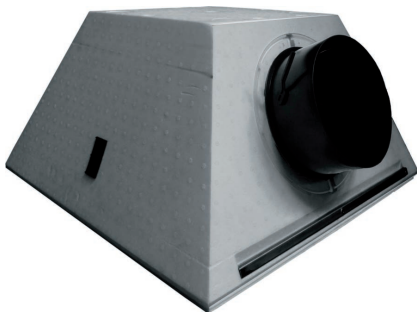

Polystyrene plenum box

Product description

Pyramidal plenum box of expanded polystyrene (high thermal and acoustic capacity).
Special for application with plate diffusers of 595x595 or larger and thickness 20 mm:
43-SF-Q, DFRO, DFRA, DFRQ, DFRE-Q, DFRE-GR-Q up to model 400, **DAFC-Q, DAFT** up to model 500, **DFRT** up to model 500, **HDPR-Q, 50-FR-4** up to model 375 and **52-FR-4-STAMP** up to model 525.

It is ideal for mounting of swirl, diffusers
Because these units are lightweight and have a trapezoidal shape, they are easily mounted in HVAC systems. Its dimensions and size make storage easy.

Material

Expanded polystyrene for isolation to UNE EN 13163.

Class E1 fire-resistant material, with a density of 45 mg/m² and grey colour.

Transmission coefficient of 0.031 W/mk.

Operation

The components are supplied loose for on-site installation.

Each plenum box has one or two connection kits according to material ordered:

Plenum box kit that includes connection neck and piecework for bridge mounting

Volume control damper kit.

The mounting bridge is included in the side of the plenum itself.

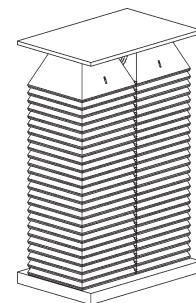

European pallet 50 units.

General dimensions

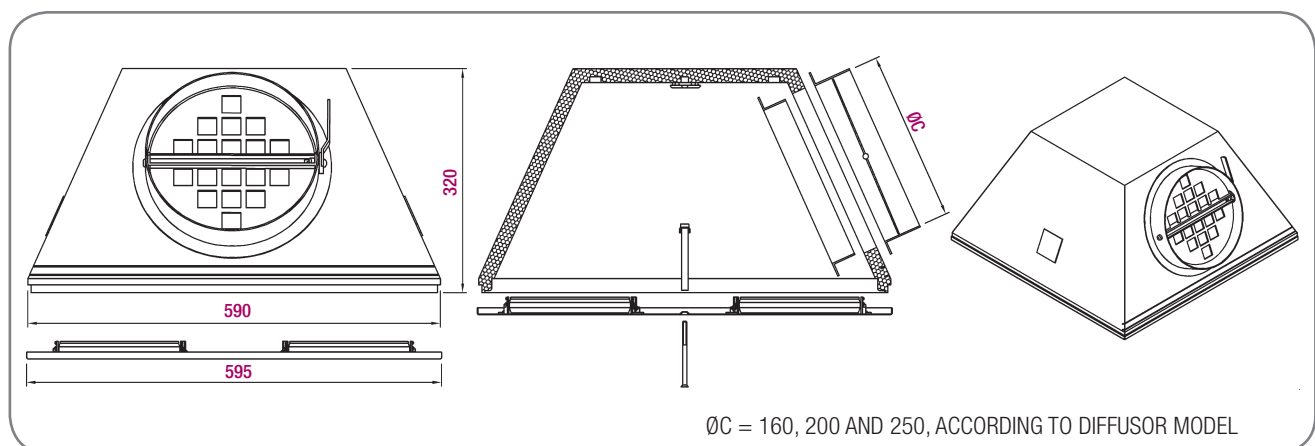

Note: For more information refer to catalogue and/or Technical Department.

KOOLAIR

KOOLAIR, S.L. (Spain)

C/ Urano, 26
Polig. Ind. nº 2 – La Fuensanta
28936 Móstoles (MADRID)
Tel: +34 91 645 00 33
Fax: +34 91 645 69 62
e-mail comercial: comercial@koolair.com
e-mail Koolair: info@koolair.com

KOOLAIR GB (Great Britain)

Unit 6
Market Industrial Estate
Yatton – Bristol
BS49 4RF
Great Britain
Tel: +44 1934 838833
Fax: +44 1934 838708
e-mail: simon.parkhouse@koolair.com

KOOLAIR, S.L. (Austria, Switzerland and Germany)

Tel: +43 664 10 10 143
e-mail: carlos.naar@koolair.com

KOOLAIR BENELUX (Belgium, Netherlands and Luxembourg)

Tel: +32 478237630
e-mail: bruno.deweever@koolair.com
Tel: +32 475727098
e-mail: mikael.lavole@koolair.com

KOOLAIR (Romania)

Tel: +40 722 291 188
e-mail: koolair.romania@koolair.ro

SAFEAIR, S.L. (Spain)

Avda. San Isidro, nave C-3
45223 Seseña – TOLEDO
Tel: +34 918098371
Fax: +34 918957798

KOOLAIR, S.L. (Portugal)

Torres de Monsanto, Rua Afonso Praça, 30
7º Piso, Miraflores - Lisboa
1495-061 - Portugal
Tel: + 351 96 707 04 54
e-mail: ricardo.fernandes@koolair.com

KOOLAIR (France)

Erwan Lacroix: Responsable Commercial
Tel: +33 (0)6 49 29 56 03
e-mail: erwan.lacroix@koolair.com
Marcos Foresi: Resp. Département Technique
Tel: +33 (0)7 52 50 47 02
e-mail: marcos.foresi@koolair.com

KOOLAIR (Morocco)

N°139. R22
Lot. Elouarda
20600. Casablanca - Morocco
Tel: +212 (0) 522 706 785
e-mail: latifa.jarmouni@koolair.com
e-mail: othman.gahiri@koolair.com

KOOLAIR MENA (Tunisia and Algeria)

Imm LOUXOR , Avenue Hedi KARRAY
1080 Centre Urbain nord, Tunis, TUNISIE
Tel: +216 98 134 000
e-mail: sofiane.jaabiri@koolair.com
e-mail: balkis.blouza@koolair.com

www.koolair.com